

DESIGNERS



WALTER SBICCA



ROMEO GUARICCI



MAMMINI CANDIDO



ERMANN0 BAUDONE



LETIZIA GIACCHI



LUCIA PIERINI



ALBERTO VALLESI



NICOLA CERASA



UTE



MARTINA BONAN
GERARDO ENRICO CIARAMBINO
MATTEO CLERICO
ADA GAROMBO



M'ILLUMINO DI EMPORIUM

“Ritrovarsi insieme è un inizio, restare insieme è un progresso, riuscire a lavorare insieme è un successo”. Emporium sceglie la prestigiosa frase di Henry Ford per ribadire l'importanza del gioco di squadra. Una squadra che sposa appieno la filosofia del pensiero positivo. Dal 1997 Emporium reinterpreta il concetto di luce e spazio, attraverso la creazione di oggetti che hanno l'ambizione di suscitare positività, ottimismo e fiducia.



Tutti i materiali plastici utilizzati sono riciclabili.



I'M ENLIGHTED WITH EMPORIUM

“Coming together is the beginning. Keeping together is progress. Working together is success”. Emporium chooses the prestigious quote of Henry Ford to reiterate the importance of teamwork. A team that fully embraces the philosophy of positive thinking. Since 1997 Emporium reinterprets the concept of light and space, through the creation of objects that have the ambition to arouse positivity, optimism and trust.



All plastic materials used are recyclable.

INDICE / INDEX

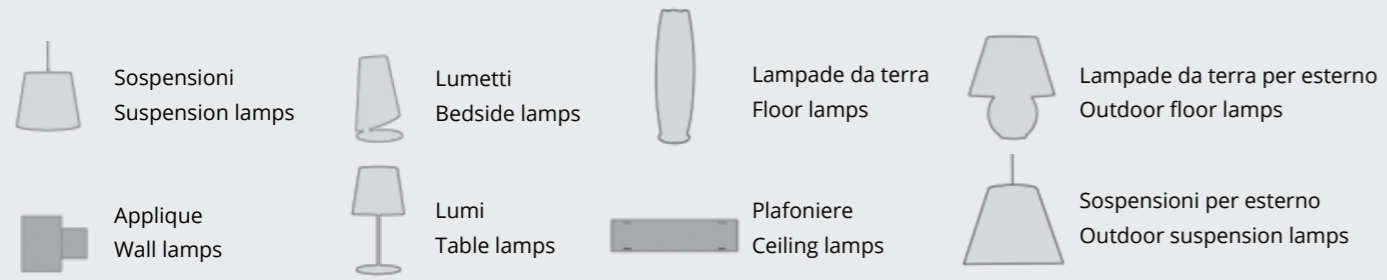

INDOOR



<i>Angipù</i>	p.8					●	●
<i>Bonbonne</i>	p.14					●	
<i>Chiara</i>	p.22					●	
<i>Atlante</i>	p.26				●		
<i>Pixi Pizzo</i>	p.30	●	●	●	●	●	
<i>Pixi</i>	p.48	●	●	●	●	●	
<i>Babette</i>	p.62	●		●	●	●	
<i>Boemia</i>	p.70	●		●	●	●	
<i>Ghirigoro</i>	p.82	●					
<i>Carioca</i>	p.84	●					
<i>Palla</i>	p.86	●					●
<i>Blunder</i>	p.90	●					
<i>Allegretta</i>	p.92	●	●		●		
<i>Cotton Light</i>	p.102	●	●	●	●		
<i>Flora</i>	p.112	●			●		
<i>Pinocchia</i>	p.118	●					
<i>Nuclea</i>	p.120	●			●	●	●
<i>Nuvola</i>	p.134	●					●

INDOOR



<i>Rigatone</i>	p.138	●	●	●	●	●	●
<i>Gemma</i>	p.150		●				●
<i>Aralia</i>	p.156	●					●
<i>Cigno</i>	p.162	●					●
<i>Amarilli</i>	p.168	●				●	
<i>Anthea</i>	p.172		●				
<i>Bea</i>	p.174	●					
<i>Bellatrix</i>	p.178	●					
<i>Bibang</i>	p.182	●					
<i>Kartika</i>	p.186	●					
<i>Arfò</i>	p.190	●					
<i>Duo</i>	p.194	●					
<i>Trio</i>	p.196	●					
<i>Ricciolo</i>	p.198	●					
<i>Ricciolino</i>	p.200	●					
<i>Lampada dell'Avvocato</i>	p.202						●
<i>Kira</i>	p.206					●	●
<i>Signorapina</i>	p.212					●	●
<i>Diva</i>	p.218						●
<i>Stone</i>	p.220						●
<i>Trilly</i>	p.222	●					
<i>Tata</i>	p.224						●
<i>Gingi</i>	p.228						●

INDOOR



<i>Track</i>	<i>p.230</i>	●					
<i>Lelle</i>	<i>p.232</i>	●					
<i>Candy</i>	<i>p.233</i>	●					
<i>Brunella</i>	<i>p.234</i>	●					
<i>Coscienza</i>	<i>p.236</i>	●					
<i>Camilla</i>	<i>p.238</i>		●				
<i>Camillatris</i>	<i>p.240</i>		●				
<i>Early</i>	<i>p.242</i>					●	
<i>Snake</i>	<i>p.244</i>					●	
<i>Truciolo</i>	<i>p.246</i>			●		●	
<i>Rosa</i>	<i>p.250</i>						●
<i>Didodado</i>	<i>p.252</i>	●	●				●
<i>Ubi</i>	<i>p.262</i>	●	●				●
<i>Dama</i>	<i>p.264</i>	●	●				●
<i>Domino</i>	<i>p.282</i>	●	●				●
<i>Incasso</i>	<i>p.294</i>						●
<i>Fortuna</i>	<i>p.296</i>						●
<i>Reload</i>	<i>p.284</i>	●				●	●
<i>Galles</i>	<i>p.290</i>	●					

OUTDOOR



<i>Bonbonne</i>	<i>p.308</i>	●	
<i>Quattrostagioni</i>	<i>p.318</i>		●
<i>Angipù</i>	<i>p.324</i>	●	
<i>Reload</i>	<i>p.328</i>	●	

TEEN LIGHT



<i>Cylinder</i>	<i>p.332</i>	●		●		
<i>Kone</i>	<i>p.336</i>	●		●		
<i>Douli</i>	<i>p.340</i>	●				
<i>Star</i>	<i>p.342</i>	●				
<i>Sol</i>	<i>p.344</i>	●				
<i>Cloud</i>	<i>p.346</i>	●				
<i>Butterfly</i>	<i>p.348</i>	●				
<i>Nevea</i>	<i>p.349</i>					●

ANGIPU'

design by **Walter Sbicca**

CL 1567

Lampada da terra per interno in metacrilato opalino, cablata con spina e interruttore, paralume decorativo in policarbonato trasparente disponibile nelle versioni : texture colore grigio - texture folk bianco. Disco di sostegno in metacrilato trasparente ,base in polipropilene bianco. (paralume personalizzabile su richiesta)

Floor lamp for interior in opal methacrylate, wired with plug and switch, decorative shade in transparent polycarbonate available in the following versions: texture gray color - white folk texture. Support disk in transparent methacrylate, base in white polypropylene. (custom lampshade on request)

91 10

Ø 59



H 88 cm

Attacco E27.
Lampadine: 1 x 70 W Max - E 27 HGS o 15 W led

E 27 Screw.
Bulbs: 1 x 70 w max - and 27 HGS or 15 W led



ANGIPU'

design by **Walter Sbicca**

CL 1568

Lampada da terra per interno in metacrilato trasparente, cablata con spina e interruttore, paralume decorativo in policarbonato trasparente disponibile nelle versioni : texture colore grigio - texture folk bianco. Disco di sostegno in metacrilato trasparente ,base in polipropilene bianco. (paralume personalizzabile su richiesta)

Floor lamp for interior in transparent methacrylate, wired with plug and switch, decorative shade in transparent polycarbonate available in the following versions: texture gray color - white folk texture. Support disk in transparent methacrylate, base in white polypropylene. (custom lampshade on request)

91 10

Ø 59



H 88 cm

Attacco E27.
Lampadine: 1 x 70 W Max - E 27 HGS o 15 W led

E 27 Screw.
Bulbs: 1 x 70 w max - and 27 HGS or 15 W led



ANGIPU'

design by **Walter Sbicca**

CL 1569

*Lampada da soffitto per interno in metacrilato opalino, paralume decorativo in policarbonato trasparente disponibile nelle versioni : texture colore grigio - texture folk bianco.
Disco di sostegno in metacrilato trasparente ,base in polipropilene bianco.
(paralume personalizzabile su richiesta)*

*Ceiling lamp for interior in opal methacrylate, decorative shade in transparent polycarbonate available in the following versions: texture gray color - white folk texture.
Support disk in transparent methacrylate, Base in white polypropylene.
(custom lampshade on request)*

91 10

∅ 59



H 88 cm

Attacco E27.
Lampadine: 1 x 70 W Max - E 27 HGS o 15 W led

E 27 Screw.
Bulbs: 1 x 70 w max - and 27 HGS or 15 W led



BONBONNE

design by **Walter Sbicca**

CL 1561

*Lampada da terra per interno in vetro stampato, cablata con spina e interruttore.
Paralume decorativo in policarbonato trasparente con texture colore marrone.
Disco di sostegno traforato in metacrilato fumè.
(paralume personalizzabile su richiesta)*

*Floor lamp for indoor, printed glass, wired with plug and switch, decorative shade in transparent polycarbonate with brown texture.
Support disk in smoked methacrylate.
(custom lampshade on request)*



59

ø 59 cm



H 82 cm

Attacco E 27.
Lampadine 2 x 70 W max
E27 - HGS

E27 screw.
Bulbs: 2 x 70 w max
E27 - HGS

BONBONNE

design by **Walter Sbicca**

CL 1564

*Lampada da terra per interno in vetro stampato, cablata con spina e interruttore.
Paralume decorativo in policarbonato trasparente con texture colore marrone.
Disco di sostegno traforato in metacrilato fumè.
(paralume personalizzabile su richiesta)*

*Floor lamp for indoor, printed glass, wired with plug and switch, decorative shade in transparent polycarbonate with brown texture.
Support disk in smoked methacrylate.
(custom lampshade on request)*



59

ø 59 cm



H 69 cm

Attacco E 27.
Lampadine 1 x 70 W max
E27 - HGS

E27 screw.
Bulbs: 1 x 70 w max
E27 - HGS



BONBONNE

design by **Walter Sbicca**

CL 1563

*Lampada da terra per interno in vetro stampato, cablata con spina e interruttore.
Paralume decorativo in Sandylex natural.
Disco di sostegno traforato in metacrilato fumè.*

*Floor lamp for indoor, printed glass, wired with plug and switch, decorative shade in natural sandylex.
Support disk in smoked methacrylate.*

10

ø 59 cm



H 82 cm

Attacco E 27.
Lampadine 2 x 70 W max
E27 - HGS

E27 screw.
Bulbs: 2 x 70 w max
E27 - HGS



BONBONNE

design by **Walter Sbicca**

CL 1566

*Lampada da terra per interno in vetro stampato, cablata con spina e interruttore.
Paralume decorativo in Sandylex natural.
Disco di sostegno traforato in metacrilato fumè.*

*Floor lamp for indoor, printed glass, wired with plug and switch, decorative shade in natural sandylex.
Support disk in smoked methacrylate.*

10

ø 59 cm



H 69 cm

Attacco E 27.
Lampadine 1 x 70 W max
E27 - HGS

E27 screw.
Bulbs: 1 x 70 w max
E27 - HGS



BONBONNE

design by **Walter Sbicca**

CL 1562

Lampada da terra per interno in vetro stampato, cablata con spina e interruttore. Paralume decorativo in Sandylex natural con texture colore marrone. Disco di sostegno traforato in metacrilato fumè. (paralume personalizzabile su richiesta)

Floor lamp for indoor, printed glass, wired with plug and switch, decorative shade in natural sandylex with brown texture. Support disk in smoked methacrylate. (custom lampshade on request)



59

ø 59 cm



H 82 cm

Attacco E 27.
Lampadine 2 x 70 W max
E27 - HGS

E27 screw.
Bulbs: 2 x 70 w max
E27 - HGS

BONBONNE

design by **Walter Sbicca**

CL 1565

Lampada da terra per interno in vetro stampato, cablata con spina e interruttore. Paralume decorativo in Sandylex natural con texture colore marrone. Disco di sostegno traforato in metacrilato fumè. (paralume personalizzabile su richiesta)

Floor lamp for indoor, printed glass, wired with plug and switch, decorative shade in natural sandylex with brown texture. Support disk in smoked methacrylate. (custom lampshade on request)



59

ø 59 cm



H 69 cm

Attacco E 27.
Lampadine 1 x 70 W max
E27 - HGS

E27 screw.
Bulbs: 1 x 70 w max
E27 - HGS



BONBONNE MINI

design by **Walter Sbicca**

CL 1597

Lampada da tavolo per interno in vetro stampato, paralume in Sandylex natural, disco traforato in metacrilato fumè.

Table lamp for indoor in printed glass, lampshade in natural sandylex, perforated disc in smoked methacrylate.

10

ø 46 cm



H 68 cm

Attacco E 27.
Lampadine 1/2 x 70 W max o 30 W led
E27 - HGS

E27 screw.
Bulbs: 1/2 x 70 W max or 30 W led
E27 - HGS



BONBONNE MINI

design by **Walter Sbicca**

CL 1596

Lampada da tavolo per interno in vetro stampato, paralume in policarbonato trasparente, disco traforato in metacrilato fumè.

Paralume disponibile nei colori: texture marrone, grigio, pizzo nero.

Table lamp for indoor in printed glass, lampshade in transparent polycarbonate, perforated disc in smoked methacrylate.

Lampshade available in the following colours: brown texture, grey, black lace.

59 91 05

ø 46 cm



H 68 cm

Attacco E 27.
Lampadine 1/2 x 70 W max o 30 W led
E27 - HGS

E27 screw.
Bulbs: 1/2 x 70 W max or 30 W led
E27 - HGS



CHIARA

design by Walter Sbicca

CL 2013

Tavolino con lampada: struttura in metallo verniciato disponibile nel colore nero.
Paralume in sandylex pearl, cablaggio rivestito in tessuto rosso.

Small table with lamp: metal structure available in black,
sandylex pearl lampshade and wiring covered with red fabric.

05

L. 53 cm



H 122 cm

Attacco E 27
Lampadine 1 x 70 W max - E27 HGS

E27 screw
Bulbs: 1 x 70 w max - E27 HGS



CHIARA

design by Walter Sbicca

CL 2013

Tavolino con lampada: struttura in metallo verniciato disponibile nel colore bianco.
Paralume in sandylex pearl, cablaggio rivestito in tessuto rosso.

Small table with lamp: metal structure available in white,
sandylex pearl lampshade and wiring covered with red fabric.

10

L 53 cm



H 122 cm

Attacco E 27
Lampadine 1 x 70 W max - E27 HGS

E27 screw
Bulbs: 1 x 70 w max - E27 HGS



ANTLANTE



ANTLANTE

design by Martina Bonan, Gerardo Enrico Ciarambino, Matteo Clerico, Ada Garombo

CL 1546

Lampada da tavolo, soggetto formica in resina con bagno galvanico in: argento, dorato, rame e bronzo.

Table lamp, resin ant subject with polishing in silver, gold, copper and bronze.

33 35 36 59

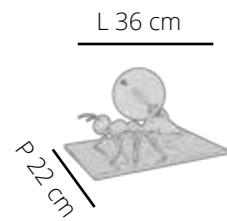

Attacco E 27.
Lampadine 1 x 70 W max E27 HGS

E27 screw.
Bulbs: 1 x 70 w max E27 HGS



PIXI PIZZO

design by UTE

CL 1536

Sospensione con paralume conico a 3 luci in policarbonato trasparente decorato con texture Pizzo nei colori: nero, bianco e rosso.

3 light polycarbonate suspension lamp with conical lampshade. Lace texture available in: black, white and red.

05 10 51

ø 66 cm



H 53 cm

Attacco E 27. Filo L. 160 cm.
Lampadine 3 x 53 W max - E27 HGS

E27 screw. Wire length 160 cm.
Bulbs: 3 x 53 w max - E27 HGS



PIXI PIZZO

design by UTE

CL 1537

Sospensione con paralume conico a 1/2 luci in policarbonato trasparente decorato con texture Pizzo nei colori: nero, bianco e rosso.

1/2 light polycarbonate suspension lamp with conical lampshade. Lace texture available in: black, white and red.

05 10 51

ø 42 cm



H 36 cm

Attacco E 27. Filo L. 160 cm.
Lampadine 1/2 x 70 W max - E27 HGS

E27 screw. Wire length 160 cm.
Bulbs: 1/2 x 70 w max - E27 HGS



PIXI PIZZO

design by UTE

CL 1538

Sospensione con paralume conico a 1 luce in policarbonato trasparente decorato con texture Pizzo nei colori: nero, bianco e rosso.

1 light polycarbonate suspension lamp with conical lampshade. Lace texture available in: black, white and red.

05 10 51

∅ 30 cm



H 27 cm

Attacco E 27. Filo L. 160 cm.
Lampadine 1 x 70 W max - E27 HGS

E27 screw. Wire length 160 cm.
Bulbs: 1 x 70 w max - E27 HGS



PIXI PIZZO

design by UTE

CL 1539

Sospensione con paralume conico a 1 luce in policarbonato trasparente decorato con texture Pizzo nei colori: nero, bianco e rosso.

1 light polycarbonate suspension lamp with conical lampshade. Lace texture available in: black, white and red.

05 10 51

ø 25 cm



H 60 cm

Attacco E 27. Filo L. 160 cm.
Lampadine 1 x 70 W max - E27 HGS

E27 screw. Wire length 160 cm.
Bulbs: 1 x 70 w max - E27 HGS



PIXI PIZZO

design by UTE

CL 1540

Applique con paralume conico in policarbonato trasparente, decorato con texture Pizzo nei colori: nero, bianco e rosso.

Polycarbonate wall lamp with conical lampshade.
Lace texture available in: black, white and red.

05 10 51

L 18 cm



H 30 cm

Attacco E 27.
Lampadine 1 x 70 W max - E27 HGS

E27 screw.
Bulbs: 1 x 70 w max - E27 HGS



PIXI PIZZO

design by UTE

CL 1542

Lampada da tavolo con paralume conico in policarbonato trasparente, decorato con texture Pizzo nei colori: nero, bianco e rosso.

Polycarbonate table lamp with conical lampshade. Lace texture available in: black, white and red.

05 10 51

ø 30 cm



H 56 cm

Attacco E 27.
Lampadine 1 x 70 W max - E27 HGS

E27 screw.
Bulbs: 1 x 70 w max - E27 HGS



PIXI PIZZO

design by UTE

CL 1544

Lumetto con paralume conico in policarbonato trasparente, decorato con texture Pizzo nei colori: nero, bianco e rosso.

Bedside table lamp. Conic lampshade in transparent polycarbonate with lace texture available in the following colours: black, white and red.

05 10 51

ø 18 cm



H 25 cm

Attacco E 14.
Lampadine 1 x 28 W max - E14 FBT

E14 screw.
Bulbs: 1 x 28 w max - E14 FBT



PIXI PIZZO

design by UTE

CL 1541

Lumetto con paralume conico in policarbonato trasparente, decorato con texture Pizzo nei colori: nero, bianco e rosso.

Polycarbonate bedside lamp with conical lampshade.
Lace texture available in: black, white and red.

05 10 51

ø 18 cm



H 32 cm

Attacco E 27.
Lampadine 1 x 70 W max - E27 HGS

E27 screw.
Bulbs: 1 x 70 w max - E27 HGS



PIXI PIZZO

design by UTE

CL 1543

Lampada da terra con paralume conico in policarbonato trasparente, decorato con texture Pizzo nei colori: nero, bianco e rosso.

Polycarbonate floor lamp with conical lampshade. Lace texture available in: black, white and red.

05 10 51

ø 40 cm



H 183 cm

Attacco E 27.
Lampadine 1 x 70 W max - E27 HGS

E27 screw.
Bulbs: 1 x 70 w max - E27 HGS



PIXI

design by UTE

CL 204

Sospensione con paralume conico in policarbonato trasparente con decoro nei colori: nero, bianco, oro e argento.

Polycarbonate suspension lamp with transparent conical lampshade.
Printed texture available in: white, black, gold and silver.

05 10 32 33

Ø 30 cm



Attacco E27 Filo L.160 cm.
Bulbs: 1 x 70 W max - E27 HGS

E27 screw. Wire length 160 cm.
Bulbs: 1 x 70 W max - E27 HGS



CL 205

Sospensione con paralume conico in policarbonato trasparente con decoro nei colori: nero, bianco, oro e argento.

Polycarbonate suspension lamp with transparent conical lampshade. Printed texture available in: white, black, gold and silver.

05 10 32 33

Ø 42 cm

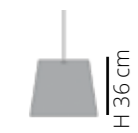

Attacco E27 Filo L.160 cm.
Bulbs: 1 x 70 W max - E27 HGS

E27 screw. Wire length 160 cm.
Bulbs: 1 x 70 W max - E27 HGS



PIXI

design by UTE

CL 360

Sospensione con paralume conico in policarbonato trasparente con decoro nei colori: nero, bianco, oro e argento.

Polycarbonate suspension lamp with transparent conical lampshade.
Printed texture available in: white, black, gold and silver.

05 10 32 33

∅ 25 cm



Attacco E27 Filo L.160 cm.
Bulbs: 1 x 70 W max - E27 HGS

E27 screw. Wire length 160 cm.
Bulbs: 1 x 70 W max - E27 HGS



PIXI

design by UTE

CL 400

Applique con paralume conico in policarbonato trasparente, con decoro nei colori: nero, bianco, oro, argento.

Polycarbonate wall lamp with transparent conical lampshade. Printed texture available in: black, white, gold and silver.

05 10 32 33

L 18 cm



H 30 cm

Attacco E 27.
Lampadine 1 x 70 W max - E27 HGS

E27 screw.
Bulbs: 1 x 70 w max - E27 HGS



PIXI

design by UTE

CL 419

Lampada da tavolo con paralume conico in policarbonato trasparente con decoro nei colori: nero, bianco, oro, argento.

Polycarbonate table lamp with transparent conical lampshade. Printed texture available in: black, white, gold and silver.

05 10 32 33

∅ 30



Attacco E27
Bulbs: 1 x 70 W max - E27 HGS

E27 screw.
Bulbs: 1 x 70 W max - E27 HGS



PIXI

design by UTE

CL 401

Lumetto con paralume conico in policarbonato trasparente con decoro nei colori: nero, bianco, oro, argento.

*Polycarbonate bedside lamp with transparent conical lampshade.
Printed texture available in: black, white, gold and silver.*

05 10 32 33

Ø 18



H 32 cm

Attacco E27
Lampadine: 1 x 70 W max - E27 HGS

E27 screw
Bulbs: 1 x 70 W max - E27 HGS



PIXI

design by UTE

CL 402

Lampada da terra con paralume conico in policarbonato trasparente con decoro nei colori: nero, bianco, oro, argento.

Polycarbonate floor lamp with transparent conical lampshade. Printed texture available in: black, white, gold and silver.

05 10 32 33

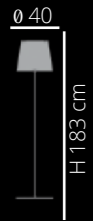

Attacco E27
Bulbs: 1 x 70 W max - E27 HGS

E27 screw
Bulbs: 1 x 70 W max - E27 HGS



BABETTE

design by UTE



CL 427

Sospensione con paralume conico in policarbonato antiriflesso con decoro nei colori: nero, bianco, oro e argento.

Polycarbonate suspension lamp with non-glare conical lampshade. Printed texture available in: black, white, gold and silver.

05 10 32 33

∅ 30 cm



H 27 cm

Attacco E27.
Filo L. 160 cm.
Lampadine: 1 x 70 W max - E27 HGS

E27 screw.
Wire length 160 cm.
Bulbs: 1 x 70 W max - E27 HGS



CL 428

Sospensione con paralume conico in policarbonato antiriflesso con decoro nei colori: nero, bianco, oro e argento.

Polycarbonate suspension lamp with non-glare conical lampshade. Printed texture available in: black, white, gold and silver.

05 10 32 33

∅ 42 cm



H 36 cm

Attacco E27.
Filo L. 160 cm.
Lampadine: 1 x 70 W max - E27 HGS

E27 screw.
Wire length 160 cm.
Bulbs: 1 x 70 W max - E27 HGS



BABETTE

design by UTE

CL 431

Lampada da tavolo con paralume conico in policarbonato antiriflesso con decoro nei colori: oro, nero, argento, bianco. Supporto in metallo cromato. Base in metacrilato bianco.

Polycarbonate table lamp with non-glare conical lampshade. Printed texture available in: gold, black, silver, white. Chromed stem. White methacrylate base.

32 05 33 10

∅ 30



H 56 cm

Attacco E27

Lampadine: 1 x 70 W max - E27 HGS

E27 screw.

Bulbs: 1 x 70 W max - E27 HGS



BABETTE

design by UTE

CL 430

Lumetto con paralume conico in policarbonato antiriflesso con decoro nei colori: nero, bianco, oro, argento.

Polycarbonate bedside lamp with non-glare conical lampshade.
Printed texture available in: black, white, gold and silver.

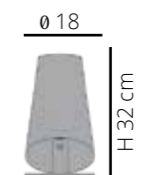

Attacco E27
Lampadine: 1 x 70 W max - E27 HGS

E27 screw.
Bulbs: 1 x 70 W max - E27 HGS

BABETTE

design by UTE

CL 432

Lampada da terra con paralume conico in policarbonato antiriflesso decorato con texture nei colori: nero, bianco, oro, argento.

Polycarbonate floor lamp with non-glare conical lampshade. Printed texture in black, white, gold and silver.

05 10 32 33

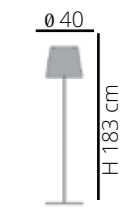

Attacco E27
Lampadine: 1 x 70 W max - E27 HGS

E27 screw.
Bulbs: 1 x 70 W max - E27 HGS



BOEMIA

design by UTE



CL 813

Sospensione con paralume conico in policarbonato con decoro diamantato nei colori: bianco, rosso, verde e grigio.

Polycarbonate suspension lamp with conical lampshade. Texture available in: white, red, green and grey.



∅ 30 cm

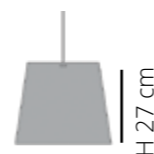

Attacco E27. Filo L.160 cm.
Lampadine: 1 x 70 W max - E27 HGS

E27 screw. Wire length 160 cm.
Bulbs: 1 x 70 W max - E27 HGS



CL 814

Sospensione con paralume conico in policarbonato con decoro diamantato nei colori: bianco, rosso, verde e grigio.

Polycarbonate suspension lamp with conical lampshade. Texture available in: white, red, green and grey.



∅ 42 cm



Attacco E27. Filo L.160 cm.
Lampadine: 1 x 70 W max - E27 HGS

E27 screw. Wire length 160 cm.
Bulbs: 1 x 70 W max - E27 HGS



CL 815

Sospensione con paralume conico a 3 luci in policarbonato con decoro diamantato nei colori: bianco, rosso, verde e grigio.

3 light polycarbonate suspension lamp with conical lampshade. Texture available in: white, red, green and grey.



∅ 66 cm



Attacco E27. Filo L.160 cm.
Lampadine: 3 x 53 W max - E27 HGS

E27 screw. Wire length 160 cm.
Bulbs: 3 x 53 W max - E27 HGS

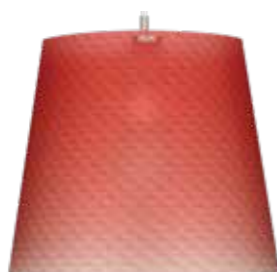

BOEMIA

design by UTE

CL 816

Sospensione con paralume conico in policarbonato con decoro diamantato nei colori: bianco, rosso, verde e grigio.

Polycarbonate suspension lamp with conical lampshade.
Texture available in: white, red, green and grey.

∅ 25 cm



H 60 cm

Attacco E27. Filo L.160 cm.
Lampadine: 1 x 70 W max - E27 HGS

E27 screw. Wire length 160 cm.
Bulbs: 1 x 70 W max - E27 HGS



10 51 20 91



BOEMIA

design by UTE

CL 820

Lampada da tavolo con paralume conico in policarbonato con decoro diamantato nei colori: bianco, rosso, verde e grigio.

Polycarbonate table lamp with conical lampshade.
Texture available in: white, red, green and grey.

10 51 20 91

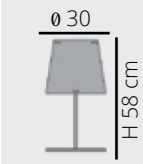

Attacco E27.
Lampadine: 1 x 70 W max - E27 HGS

E27 screw.
Bulbs: 1 x 70 W max - E27 HGS



BOEMIA

design by UTE

CL 819

Lampada da tavolo con paralume conico in policarbonato con decoro diamantato nei colori: bianco, rosso, verde e grigio.

Polycarbonate table lamp with conical lampshade.
Texture available in: white, red, green and grey.

10 51 20 91

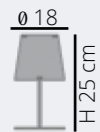

Attacco E14.
Lampadine: 1 x 28 W max - E14 FBT

E14 screw.
Bulbs: 1 x 28 W max - E14 FBT



BOEMIA

design by UTE

CL 818

Lumetto con paralume conico in policarbonato con decoro diamantato nei colori: bianco, rosso, verde e grigio.

Polycarbonate bedside lamp with conical lampshade. Texture available in: white, red, green and grey.

10 51 20 91

∅ 18



H 32 cm

Attacco E27.
Lampadine: 1 x 70 W max - E27 HGS

E27 screw.
Bulbs: 1 x 70 W max - E27 HGS

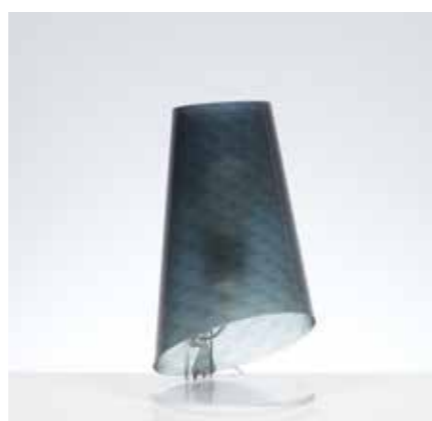
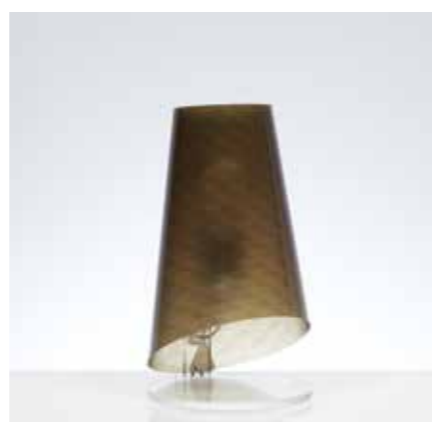

BOEMIA

design by UTE

CL 821

Lampada da terra con paralume conico in policarbonato con decoro diamantato nei colori: bianco, rosso, verde e grigio.

Polycarbonate floor lamp with conical lampshade.
Texture available in: white, red, green and grey.

10 51 20 91

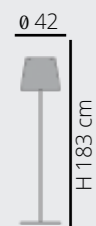

Attacco E27.
Lampadine: 1 x 70 W max - E27 HGS

E27 screw.
Bulbs: 1 x 70 W max - E27 HGS



GHIRIGORO

design by UTE

CL 547

Sospensione. Supporto in metacrilato satinato, paralume in policarbonato trasparente con texture effetto lino colore bianco. Particolari in ottone cromato.

Suspension lamp. Lampshade in polycarbonate with white linen-like decoration. Chromed metal details.

10

Ø 56



H 64 cm

Attacco E27. Filo L. 160 cm
Lampadine: 1 x 70 W max - E27 HGS

E27 screw. Wire length 160 cm.
Bulbs: 1 x 70 W max - E27 HGS



CARIOCA

design by UTE

CL 325

Sospensione in metacrilato disponibile nei colori verde, giallo, arancio, rosa, rosso, blu e multicolor.

Methacrylate suspension lamp available in: green, yellow, orange, pink, red, blue and multicolor.

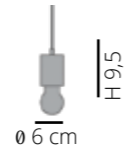

Attacchi E27. Filo L 160 cm.
Lampadine: 1 x 70 W max - E27 HGS

E27 screw. Wire length 160 cm.
Bulbs: 1 x 70 W max - E27 HGS



PALLA

design by UTE

CL 1571

Sospensione in polimero metacrilato.

Suspension lamp in methacrylate polymer.

14

Ø 40 cm



Attacco E27. Filo L. 160 cm.
Lampadine : 1 x 70 W max - E27 HGS

E27 screw. Wire length 160 cm.
Bulbs: 1 x 70 W max - E27 HGS



CL 1572

Sospensione in polimero metacrilato.

Suspension lamp in methacrylate polymer.

14

Ø 50 cm



Attacco E27. Filo L. 160 cm.
Lampadine : 1 x 70 W max - E27 HGS

E27 screw. Wire length 160 cm.
Bulbs: 1 x 70 W max - E27 HGS



CL 1573

Sospensione in polimero metacrilato.

Suspension lamp in methacrylate polymer.

14

Ø 60 cm



Attacco E27. Filo L. 160 cm.
Lampadine : 2 x 70 W max - E27 HGS

E27 screw. Wire length 160 cm.
Bulbs: 2 x 70 W max - E27 HGS



PALLA

design by UTE

CL 1574

Plafoniera In polimero metacrilato.

Ceiling lamp in methacrylate polymer.

14

Ø 40 cm



Attacco E27
Lampadine : 1 x 70 W max - E27 HGS

E27 screw.
Bulbs: 1 x 70 W max - E27 HGS



CL 1575

Plafoniera In polimero metacrilato.

Ceiling lamp in methacrylate polymer.

14

Ø 50 cm



Attacco E27
Lampadine : 1 x 70 W max - E27 HGS

E27 screw.
Bulbs: 1 x 70 W max - E27 HGS



CL 1576

Plafoniera In polimero metacrilato.

Ceiling lamp in methacrylate polymer.

14

Ø 60 cm



Attacco E27
Lampadine : 2 x 70 W max - E27 HGS

E27 screw.
Bulbs: 2 x 70 W max - E27 HGS



BLUNDER

design by **ERMANN0 BAUDONE**

CL 1545

Sospensione in cristallo acrilico prismatico a 1 luce disponibile nei colori: trasparente, verde, giallo, viola, rosso e celeste.

1 light prism-like crystal suspension lamp in acrylic, available in the following colors: transparent, green, yellow, violet, red and light blue.

11 20 21 29 51 64

L 50 cm



H 26 cm

Attacco E 27. Filo L. 160 cm.
Lampadine 1 x 70 W max - E27 HGS

E27 screw. Wire length 160 cm.
Bulbs: 1 x 70 w max - E27 HGS



ALLEGRETTA

design by Romeo Guaricci

CL 1400

Sospensione in metacrilato disponibile nei colori: satinato, spectrall e fumé.

Methacrylate suspension lamp available in: opaline white, spectrall and smoked grey.

12 88 98

∅ 40 cm



Attacco E27. Filo L.160 cm.
Lampadine: 1 x 70 W max - E27 HGS

E27 screw. Wire length 160 cm.
Bulbs: 1 x 70 W max - E27 HGS



CL 1401

Sospensione in metacrilato disponibile nel colore: texturgold.

Methacrylate suspension lamp available in: texturgold.

58



ALLEGRETTA

design by Romeo Guaricci

∅ 22 cm



Attacco E14. Filo L.160 cm.
Lampadine: 1 x 15 W max - E14 FBT

E14 screw. Wire length 160 cm.
Bulbs: 1 x 15 W max - E14 FBT



CL 1402 12 88 98

Sospensione in metacrilato disponibile nei colori:
satinato, spectrall e fumé.

Methacrylate suspension lamp available in:
opaline white, spectrall and smoked grey.

CL 1403 58

Sospensione in metacrilato disponibile nel colore: texturgold.
Methacrylate suspension lamp available in: texturgold.

∅ 22 cm



Attacco E14. Filo L.160 cm.
Lampadine: 2 x 15 W max - E14 FBT

E14 screw. Wire length 160 cm.
Bulbs: 2 x 15 W max - E14 FBT



CL 1404 12 88 98

Sospensione in metacrilato disponibile nei colori:
satinato, spectrall e fumé.

Methacrylate suspension lamp available in:
opaline white, spectrall and smoked grey.

CL 1405 58

Sospensione in metacrilato disponibile nel colore: texturgold.
Methacrylate suspension lamp available in: texturgold.

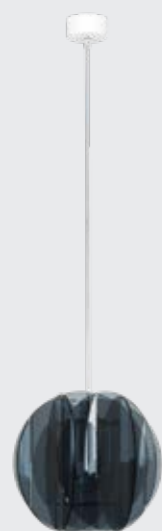

ALLEGRETTA

design by Romeo Guaricci

CL 1406

Applique in metacrilato disponibile nei colori: satinato, spectrall e fumé.

Methacrylate wall lamp available in: opaline white, spectrall and smoked grey.

12 88 98

Ø 24



Attacco E14.
Lampadine: 1 x 15 W max - E14 FBT

E14 screw.
Bulbs: 1 x 15 W max-E14 FBT



CL 1407

Applique in metacrilato disponibile nel colore: texturgold.

Methacrylate wall lamp available in: texturgold.

58



ALLEGRETTA

design by Romeo Guaricci

CL 1408

Lampada da tavolo in metacrilato disponibile nei colori:
satinato, spectrall e fumé.

Methacrylate table lamp available in:
opaline white, spectrall and smoked grey.

12 88 98

Ø 22 cm Attacco E14.
Lampadine: 1 x 15 W max - E14 FBT



E14 screw.
Bulbs: 1 x 15 W max - E14 FBT



CL 1409

Lampada da tavolo in metacrilato disponibile nel colore: TexturGold

Methacrylate table lamp available in: TexturGold.

58



ALLEGRETTA

design by Romeo Guaricci



COTTON LIGHT

design by Mammini Candido

CL 1462

Sospensione 3 luci in sandylex bianco pearl.

3 light suspension lamp in pearl white sandylex.

15

Ø 63



Attacco E27. Filo L 160 cm.
Lampadine: 1/2 x 70W max - E27 HGS

E27 screw. Wire length 160 cm.
Bulbs: 1/2 x 70W max - E27 HGS



CL 1463

Sospensione 3 luci in sandylex bianco pearl con decori viola o grigio.

3 light suspension lamp in purple or grey sandylex.

29 91



COTTON LIGHT

design by Mammini Candido

CL 1464

Sospensione in sandylex bianco pearl.

Suspension lamp in pearl white sandylex.

15

Ø 46

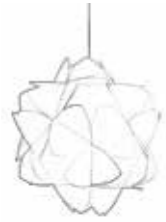

Attacco E27. Filo L 160 cm.
Lampadine: 1/2 x 70W max - E27 HGS

E27 screw. Wire length 160 cm.
Bulbs: 1/2 x 70W max - E27 HGS



CL 1465

Sospensione in sandylex bianco pearl con decori viola o grigio.

Suspension lamp in purple or grey sandylex.

29 91



COTTON LIGHT

design by Mammini Candido

CL 1470

Applique in sandylex pearl.

Wall lamp in pearl sandylex.

15



P 18 cm



Ø 35 cm

Attacco E27
Lampadine: 1 x 70W max - E27 HGS

E27 screw
Bulbs: 1 x 70W max - E27 HGS

CL1471

Applique in sandylex pearl. Versione con decoro nei colori: grigio e viola.

Wall lamp in pearl sandylex. Texture available in grey and purple.

91 29



P 18 cm



Ø 35 cm

Attacco E27
Lampadine: 1 x 70W max - E27 HGS

E27 screw
Bulbs: 1 x 70W max - E27 HGS



COTTON LIGHT

design by Mammini Candido

CL1466

Lampada da tavolo in sandylex pearl.

Table lamp in pearl sandylex.

15

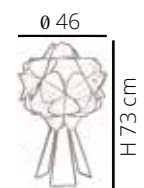

Attacco E 27
Lampadine: 1 x 70 W max - E27 HGS
E27 screw.
Bulbs: 1 x 70W max - E27 HGS

CL 1467

Lampada da tavolo in sandylex pearl.
Versione con decoro nei colori: grigio e viola.

Table lamp in pearl sandylex.
Texture available in: grey and purple.

29 91



COTTON LIGHT

design by Mammini Candido

CL 1468

Abat-jour in sandylex pearl.

Bedside lamp in pearl sandylex.

15

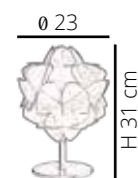

Attacco E14
Lampadine 1 x 28 W max - E 14 FBT

E14 screw.
Bulbs 1 x 28 W max - E14 FBT

CL 1469

Abat-jour in sandylex pearl. Versione con decoro nei colori:
grigio e viola.

Bedside lamp in pearl sandylex. Texture available in grey and
purple

29 91



FLORA

design by Romeo Guaricci

CL 1426

Sospensione in sandylex nel colore oроpearl. Supporto in metacrilato trasparente.

Suspension lamp in sandylex, oроpearl color.

15

Lampadine: 1x70W max - E27 HGS
Bulbs: 1x70W max - E27 HGS



15

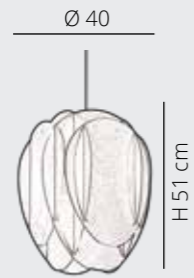

FLORA

design by Romeo Guaricci

CL 1436

Lampada da tavolo in sandylex nel colore oropearl.

Table lamp in oropearl sandylex.

15

Ø 23



H 30 cm

Attacco E14.
Lampadine: 1x28 W max - E14 FBT
E14 screw.
Bulbs: 1x28 W max - E14 FBT

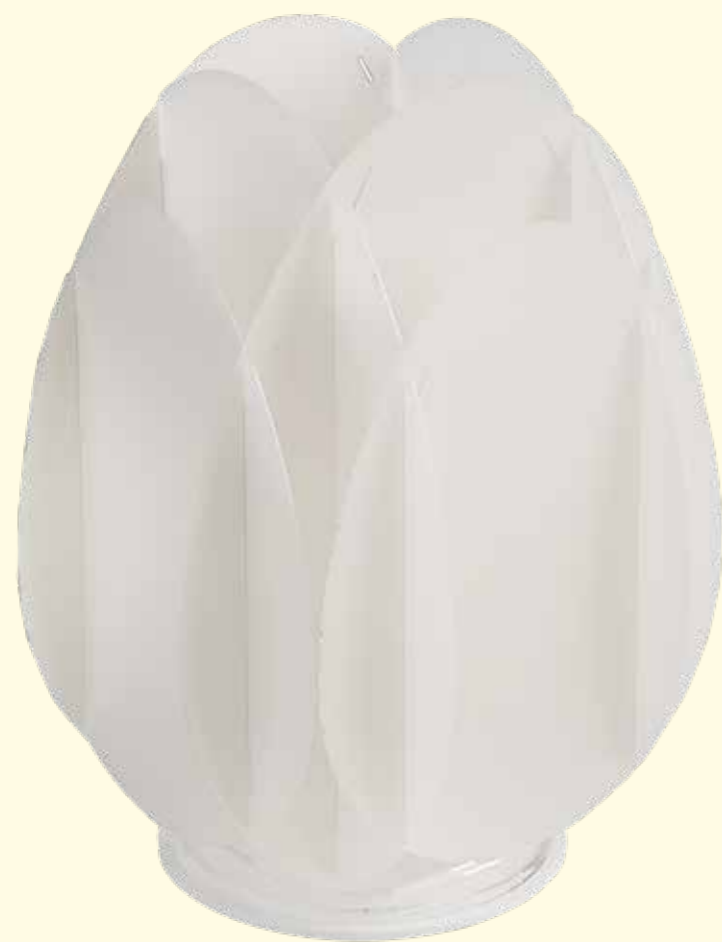

FLORA

design by Romeo Guaricci

CL 1431

Lampada da terra con paralume in sandylex nel colore oropearl.

Floor lamp with oropearl sandylex lampshade.

15

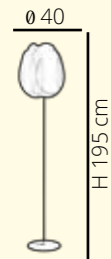

Attacco E27.
Lampadine 1 x 70 W max - E27 HGS

E27 screw.
Bulbs: 1 x 70 W max - E27 HGS



PINOCCHIA

design by UTE

CL 373

Sospensione con paralume conico in Sandylex pearl.

Polypropylene suspension lamp with white pearl conical lampshade.

15



∅ 40 cm



H 60 cm

Attacco E27. Filo L.160 cm.
Lampadine : 1 x 70 W max - E27 HGS

E27 screw. Wire length 160 cm.
Bulbs: 1 x 70 W max - E27 HGS



CL 372

Sospensione con paralume conico in Sandylex con stampa geometrica disponibile nei colori: grigio, giallo, rosso, azzurro.

Polypropylene suspension lamp. Printed texture lampshade available in: grey, red, yellow, blue.

91

21

51

61



NUCLEA

design by UTE





Sospensione a 3 luci in metacrilato disponibile nei colori:

3 light methacrylate suspension lamp available in:

CL 129 satinato, rosso, fumé e spectrall. opaline white, red, smoked grey and spectrall.

12 51
98 88

CL 643 cromolite

55

CL 132 texturgold

58

CL 869 decoro nuance nei colori: rosso e grigio. natural opal version available in: red or grey.

53 91

∅ 67 cm



Attacco E27. Filo L.160 cm.
Lampadine: 3 x 53 W max - E27 HGS

E27 screw. Wire length 160 cm.
Bulbs: 3 x 53 W max - E27 HGS



Sospensione in metacrilato disponibile nei colori:

Methacrylate suspension lamp available in:

CL 128 satinato, rosso, fumé e spectrall. opaline white, red, smoked grey and spectrall.

12 51
98 88

CL 642 cromolite

55

CL 131 texturgold

58

CL 868 decoro nuance nei colori: rosso e grigio. natural opal version available in: red or grey.

53 91

∅ 53 cm

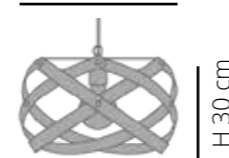

Attacco E27. Filo L.160 cm.
Lampadine: 1 x 70 W max - E27 HGS

E27 screw. Wire length 160 cm.
Bulbs: 1 x 70 W max - E27 HGS



Sospensione in metacrilato disponibile nei colori:

Methacrylate suspension lamp available in:

CL 127 satinato, rosso, fumé e spectrall. opaline white, red, smoked grey and spectrall.

12 51
98 88

CL 641 cromolite

55

CL 130 texturgold

58

CL 867 decoro nuance nei colori: rosso e grigio. natural opal version available in: red or grey.

53 91

∅ 40 cm



Attacco E27. Filo L.160 cm.
Lampadine: 1 x 70 W max - E27 HGS

E27 screw. Wire length 160 cm.
Bulbs: 1 x 70 W max - E27 HGS



NUCLEA

design by UTE

∅ 40 cm



H 58 cm

Attacco E27.
Lampadine: 1 x 70 W max - E27 HGS

E27 screw.
Bulb: 1x70 W max E27 - HGS

CL 490

Lampada da tavolo in metacrilato disponibile nei colori: satinato, rosso, fumé e spectrall.

Methacrylate table lamp available in: opaline white, red, smoked grey and spectrall.

12 51 98 88



CL 646 cromolite

55



CL 491 TexturGold

58



CL 872

Versione natural opal con decoro nuance nei colori: rosso e grigio.

Natural opal version available in: red or grey.

91 53

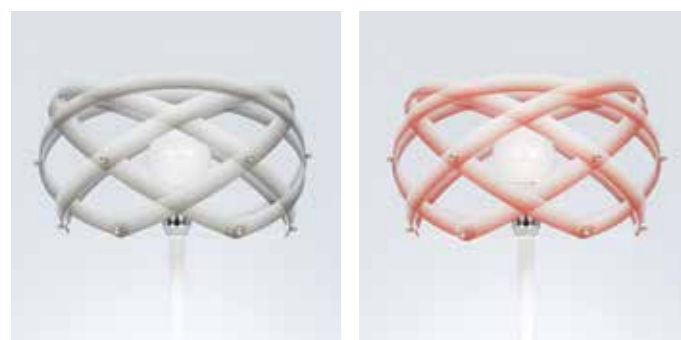

NUCLEA

design by UTE

CL 493

Lampada da terra in metacrilato disponibile nei colori: satinato, rosso, fumé e spectrall.

Methacrylate floor lamp available in: opaline white, red, smoked grey and spectrall.

12 51 98 88

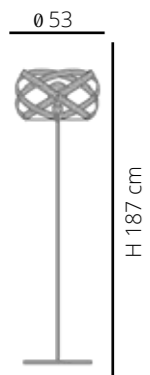

Attacco E27.
Lampadine: 1 x 70 W max - E27 HGS

E27 screw.
Bulbs: 1 x 70 W max - E27 HGS

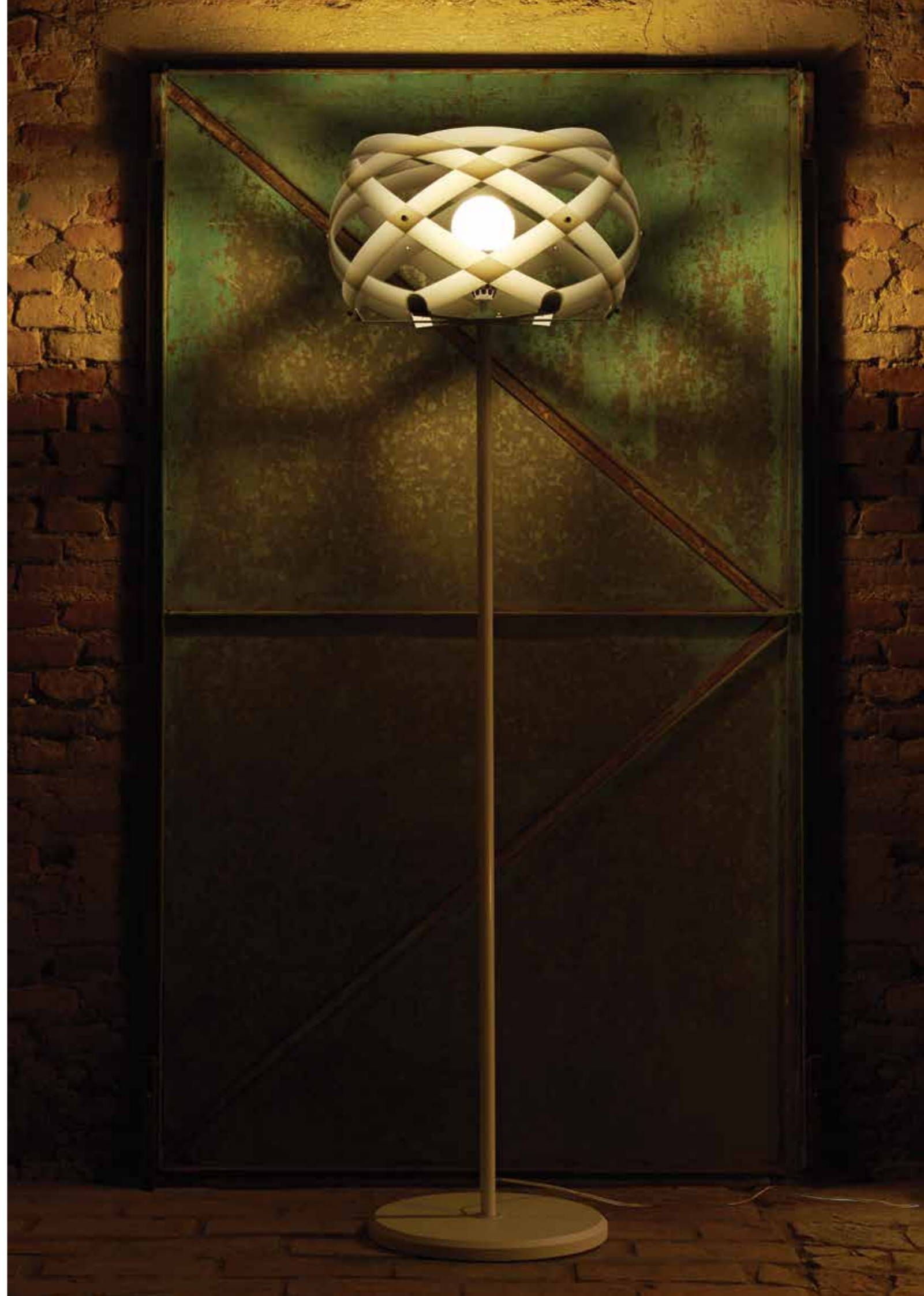

NUCLEA

design by UTE

CL 647

Lampada da terra in metacrilato disponibile nel colore: cromolite.

Methacrylate floor lamp available in: cromolite.



55

CL 494

Lampada da terra in metacrilato disponibile nel colore: TexturGold.

Methacrylate floor lamp available in: TexturGold.



58

CL 873

Versione natural opal con decoro nuance nei colori: rosso e grigio.

Natural opal version available in: red or grey.



53 91



NUCLEA

design by UTE





12 51 98 88

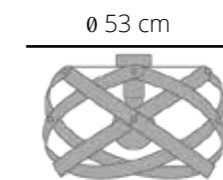

Attacco E27.
Lampadine: 1 x 70 W max - E27 HGS
E27 screw.
Bulbs: 1 x 70 W max - E27 HGS

Plafoniera in metacrilato disponibile nei colori:
Methacrylate ceiling lamp available in:

CL 454 satinato, rosso, fumé e spectrall.
opaline white, red, smoked grey and spectrall.

12 51 88 98

CL 645 cromolite

55

CL 455 texturgold

58

CL 871 decoro nuance nei colori: rosso e grigio.
Natural opal version available in: red or grey.

53 91



55



58



53 91

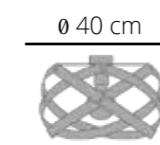

Attacco E27.
Lampadine: 1 x 70 W max - E27 HGS
E27 screw.
Bulbs: 1 x 70 W max - E27 HGS

Plafoniera in metacrilato disponibile nei colori:
Methacrylate ceiling lamp available in:

CL 452 satinato, rosso, fumé e spectrall.
opaline white, red, smoked grey and spectrall.

12 51 88 98

CL 644 cromolite

55

CL 453 texturgold

58

CL 870 decoro nuance nei colori: rosso e grigio.
Natural opal version available in: red or grey.

53 91

NUVOLA

design by UTE

CL 602

Sospensione in metacrilato, disponibile nei colori: satinato, rosso, fumé e spectrall.

Methacrylate suspension lamp available in: opaline white, red, smoked grey, and spectrall.

12 51 98 88



Ø 56 cm



H 31 cm

Attacco E27. Filo L. 160 cm.
Lampadine : 1 x 70 W max - E27 HGS

E27 screw. Wire length cm 160.
Bulbs: 1 x 70 W max - E27 HGS



CL 603

Sospensione in metacrilato, disponibile nel colore: oro and cromolite. (Ø 44 solo cromolite)

Methacrylate suspension lamp available in: gold and cromolite. (Ø 44 only cromolite)

57 55

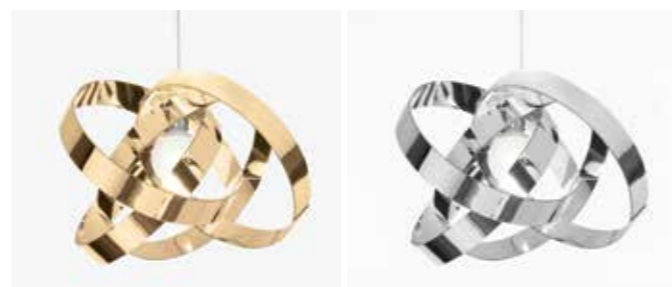

CL 692

Sospensione in metacrilato, disponibile nel colore: texturgold. Ø 56

Methacrylate suspension lamp available in: texturgold. Ø 56

58



CL 878

Sospensione in metacrilato, disponibile nella versione natural opal con decoro nuance nei colori: rosso e grigio. Ø 56

Methacrylate suspension lamp.
Natural opal version available in: red or grey. Ø 56

53 91

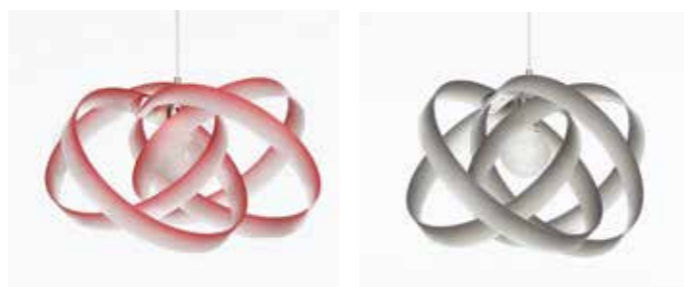

CL 880

Sospensione in metacrilato, disponibile nella versione bicolor: cromolite/satinato - gold/satinato. (Ø 54 solo bicolor cromolite)

Methacrylate suspension lamp. Bicolor version available in: cromolite/opaline white - gold/opaline white. (Ø 54 only bicolor cromolite)

95 97



NUVOLA

design by UTE

CL 591

Plafoniera in metacrilato, disponibile nei colori: satinato, rosso, fumé e spectrall.

Methacrylate ceiling lamp available in: opaline white, red, smoked grey, and spectrall.

12 51 98 88

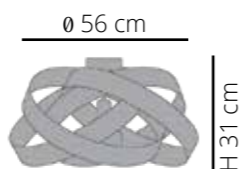
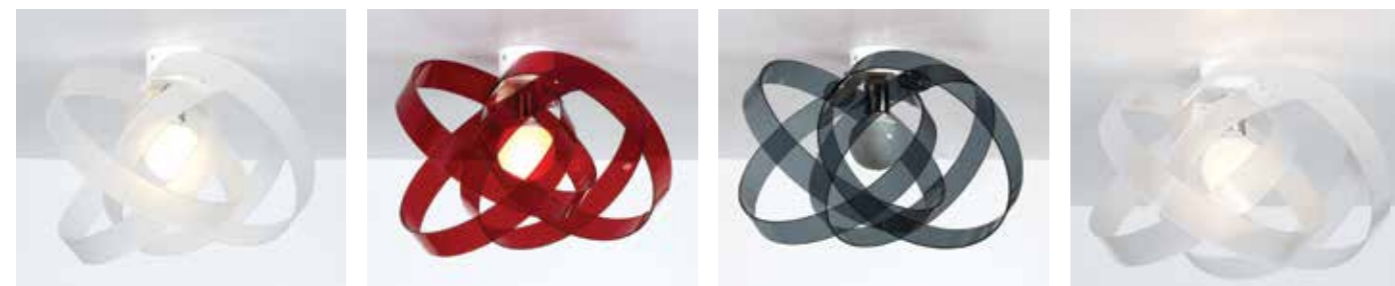

Attacco E27.
Lampadine : 1 x 70 W max - E27 HGS
E27 screw.
Bulbs: 1 x 70 W max - E27 HGS

CL 592

Plafoniera in metacrilato, disponibile nel colore: oro e cromolite. (ø 44 solo cromolite)

Methacrylate ceiling lamp available in: gold and cromolite. (ø 44 only cromolite)

57 55



CL 693

Plafoniera in metacrilato, disponibile nel colore: texturgold. ø 56

Methacrylate ceiling lamp available in: texturgold. ø 56

58



CL 879

Plafoniera in metacrilato, disponibile nella versione natural opal con decoro nuance nei colori: rosso e grigio. ø 56

Methacrylate ceiling lamp. Natural opal version available in: red or grey. ø 56

53 91

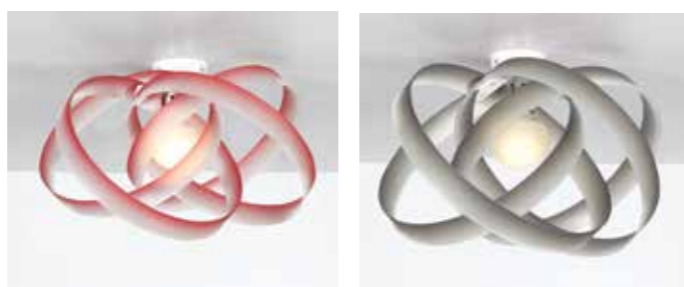

CL 881

Plafoniera in metacrilato, disponibile nella versione bicolor: cromolite/satinato - gold/satinato. (ø 54 solo bicolor cromolite)

Methacrylate ceiling lamp. Bicolor version available in: cromolite/opaline white - gold/opaline white. (ø 54 only bicolor cromolite)

95 97

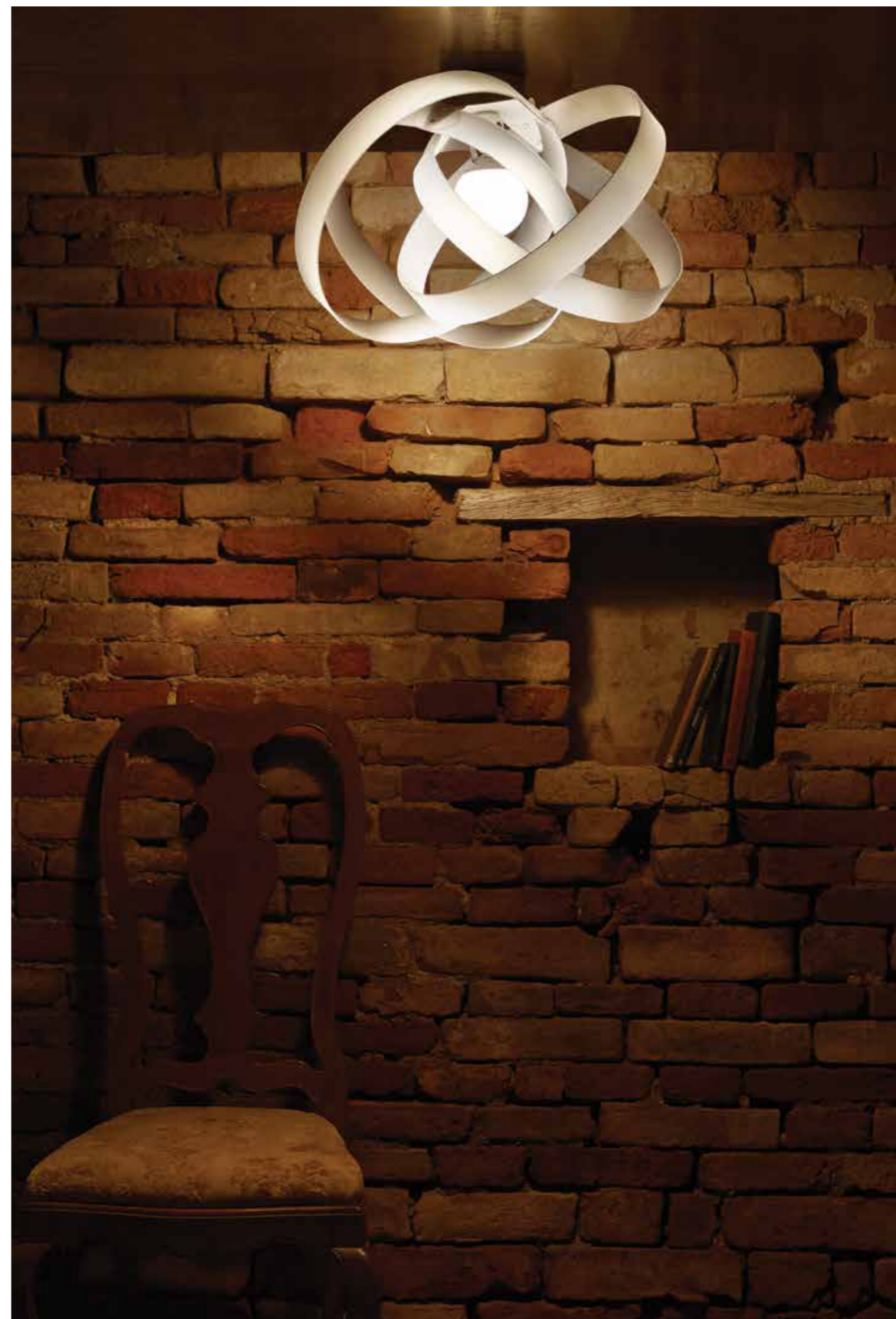
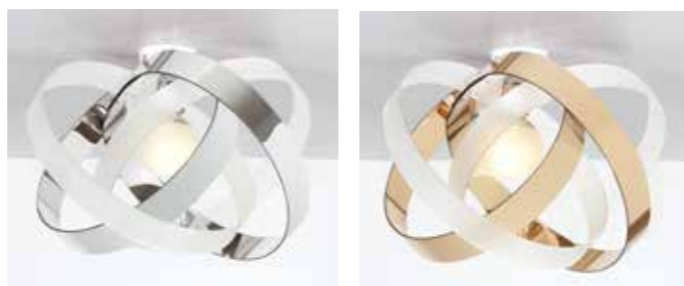

RIGATONE

design by UTE

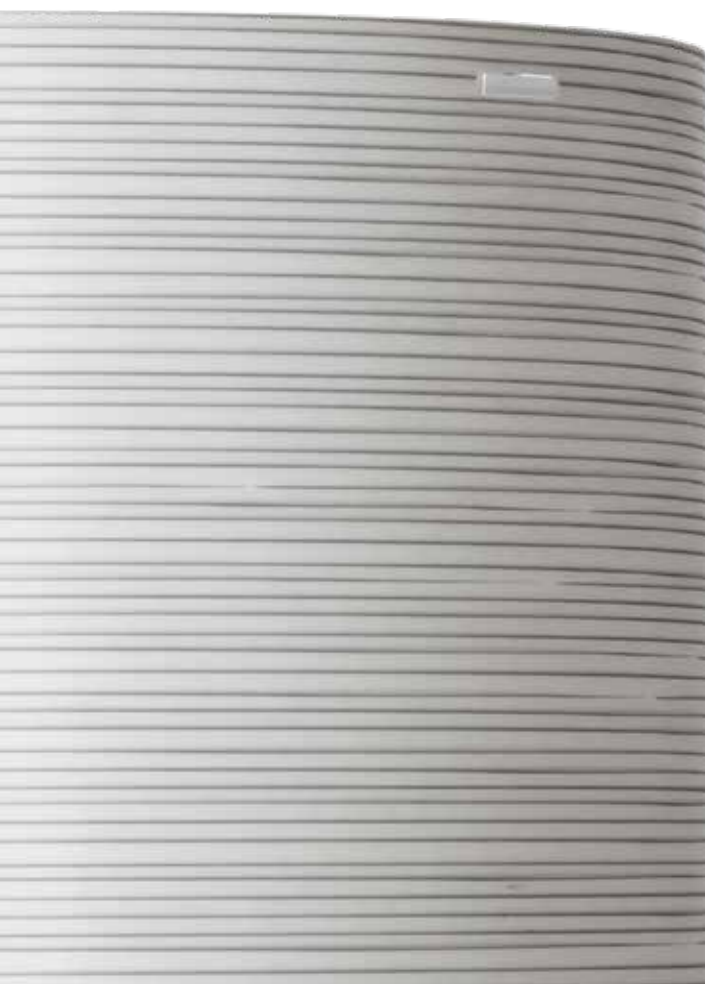

RIGATONE

design by UTE

CL 885

Sospensione con paralume cilindrico in polipropilene bianco perla con decoro fili. Struttura in metacrilato finitura spectrall e satinato.

Suspension lamp. White pearl cylindrical polypropylene lampshade with thread texture. Methacrylate structure in spectrall and opaline white finish.

89



∅ 30 cm

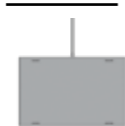

H 19,6 cm

Attacco E27. Filo L 160 cm.
Lampadine: 1 x 70 W max - E27 HGS

E27 screw. Wire length 160 cm.
Bulbs: 1 x 70 W max - E27 HGS



CL 886

Sospensione con paralume cilindrico in polipropilene bianco perla con decoro fili. Struttura in metacrilato finitura spectrall e satinato.

Suspension lamp. White pearl cylindrical polypropylene lampshade with thread texture. Methacrylate structure in spectrall and opaline white finish.

89



∅ 45 cm

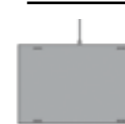

H 29 cm

Attacco E27. Filo L 160 cm.
Lampadine: 2 x 53 W max - E27 HGS

E27 screw. Wire length 160 cm.
Bulbs: 2 x 53 W max - E27 HGS



RIGATONE

design by UTE

CL 887

Sospensione con paralume cilindrico in polipropilene bianco perla con decoro fili. Struttura in metacrilato finitura spectrall e satinato.

Suspension lamp. White pearl cylindrical polypropylene lampshade with thread texture. Methacrylate structure in spectrall and opaline white finish.

89



∅ 60 cm



H 37,5 cm

Attacco E27. Filo L 160 cm.
Lampadine: 3 x 53 W max - E27 HGS

E27 screw. Wire length 160 cm.
Bulbs: 3 x 53 W max - E27 HGS



CL 888

Sospensione con paralume cilindrico in polipropilene bianco perla con decoro fili. Struttura in metacrilato finitura spectrall e satinato.

Suspension lamp. White pearl cylindrical polypropylene lampshade with thread texture. Methacrylate structure in spectrall and opaline white finish.

89



∅ 17 cm



H 38 cm

Attacco E27. Filo L 160 cm.
Lampadine: 1 x 70 W max - E27 HGS

E27 screw. Wire length 160 cm.
Bulbs: 1 x 70 W max - E27 HGS



RIGATONE

design by UTE

CL 892

Applique a 2 luci con paralume in polipropilene bianco perla con decoro fili.

2 light wall lamp. White pearl polypropylene lampshade with thread texture.

89

L 10 cm



Attacco E14

Lampadine: 2 x 15 W max - E14 FBT

E14 screw

Bulbs: 2 x 15 W max - E14 FBT



CL 893

Applique a 2 luci con paralume in polipropilene bianco perla con decoro fili.

2 light wall lamp. White pearl polypropylene lampshade with thread texture.

89

L 18 cm



Attacco E14

Lampadine: 2 x 15 W max - E14 FBT

E14 screw

Bulbs: 2 x 15 W max - E14 FBT



RIGATONE

design by UTE

CL 894

Lampada da tavolo. Paralume cilindrico in polipropilene bianco perla con decoro fili. Struttura in metacrilato finitura spectrall e satinato.

Table lamp. White pearl cylindrical poliporopylene lampshade with thread texture. Methacrylate structure with spectrall and opaline white finish.

89

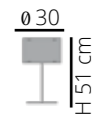

Attacco E27.
Lampadine: 1 x 70 W max - E27 HGS

E27 screw.
Bulbs: 1 x 70 W max - E27 HGS



CL 895

Lumetto. Paralume cilindrico in polipropilene bianco perla con decoro fili. Struttura in metacrilato finitura spectrall e satinato.

Bedside lamp. White pearl cylindrical poliporopylene lampshade with thread texture. Methacrylate structure with spectrall and opaline white finish.

89

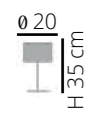

Attacco E14.
Lampadine: 1 x 15 W max - E14 FBT

E14 screw.
Bulbs: 1 x 15 W max - E14 FBT



RIGATONE

design by UTE

CL 896

Lampada da terra. Paralume cilindrico in polipropilene bianco perla con decoro fili. Struttura in metacrilato finitura spectrall e satinato.

Floor lamp. White pearl cylindrical poliporopylene lampshade with thread texture. Methacrylate structure with spectrall and opaline white finish.

89

Ø 45

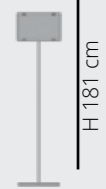

Attacco E27.
Lampadine: 1 x 70 W max - E27 HGS

E27 screw.
Bulbs: 1 x 70 W max - E27 HGS





CL 889

Plafoniera con paralume cilindrico in polipropilene bianco perla con decoro fili. Struttura in metacrilato finitura spectrall e satinato.

Ceiling lamp. White pearl cylindrical polypropylene lampshade with thread texture. Methacrylate structure in spectrall and opaline white finish.

Attacco E27.
Lampadine: 1 x 42 W max - E27 HGS

E27 screw.
Bulbs: 1 x 70 W max - E27 HGS

Ø 30 cm

H 14,4 cm

89

CL 890

Plafoniera a 2 luci con paralume cilindrico in polipropilene bianco perla con decoro fili. Struttura in metacrilato finitura spectrall e satinato.

2 light ceiling lamp. White pearl cylindrical polypropylene lampshade and thread texture. Methacrylate structure in spectrall and opaline white finish.

Attacco E27.
Lampadine: 2 x 42 W max - E27 HGS

E27 screw.
Bulbs: 2 x 42 W max - E27 HGS

Ø 45 cm

H 14,4 cm

89

CL 891

Plafoniera a 3 luci con paralume cilindrico in polipropilene bianco perla con decoro fili. Struttura in metacrilato finitura spectrall e satinato.

3 light ceiling lamp. White pearl cylindrical polypropylene lampshade with thread texture. Methacrylate structure in spectrall and opaline white finish.

Attacco E27.
Lampadine: 3 x 42 W max - E27 HGS

E27 screw.
Bulbs: 3 x 42 W max - E27 HGS

Ø 60 cm

H 14,4 cm

89

GEMMA

design by Romeo Guaricci

CL 1488

Applique con calotta in PMMA opal diffusore.
Fregio in sandylex pearl.

Wall lamp in pearl white PMMA.

15



P 13 cm



Ø 28 cm

Attacco E27
Lampadine: 1 x 70W max - E27 HGS

E27 screw
Bulbs: 1 x 70W max - E27 HGS

CL 1489

Applique con calotta in PMMA opal diffusore. Fregio in sandylex
pearl. Versione con decoro nei colori:
reddish e darkgray.

Wall lamp in pearl white PMMA. Texture available in:
reddish or darkgray sandylex.

41 94



P 13 cm



Ø 28 cm

Attacco E27
Lampadine: 1 x 70W max - E27 HGS

E27 screw
Bulbs: 1 x 70W max - E27 HGS

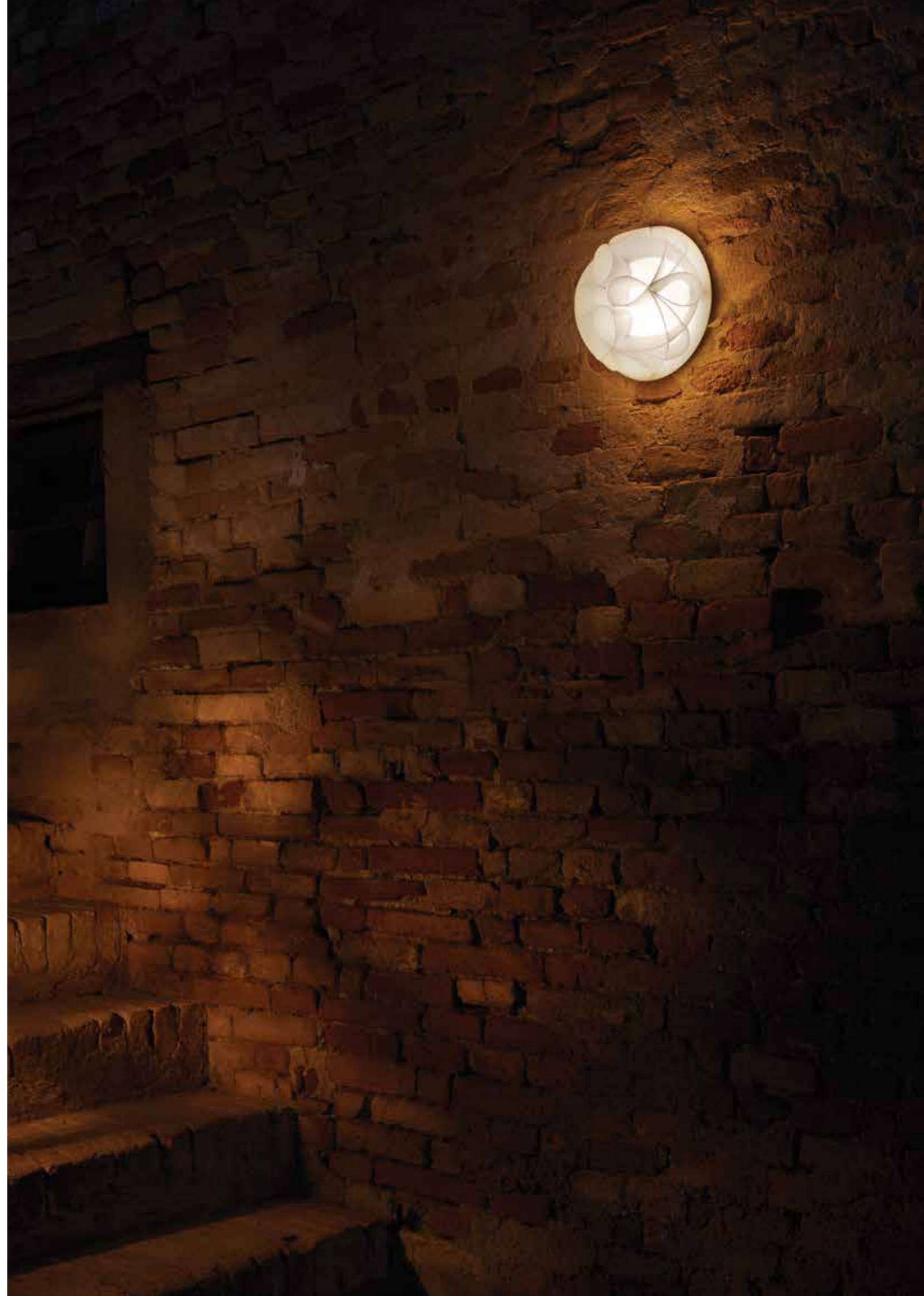

GEMMA

design by Romeo Guaricci

CL 1482

Plafoniera 4 luci con calotta in PMMA opal diffusore. Fregio in sandylex pearl.

4 light ceiling lamp in pearl white PMMA.



15

Ø 70 cm



H 22 cm

Attacco E27

Lampadine: 4 x 42 W max - E27 HG

E27 screw

Bulbs: 4 x 42 W max - E27 HGS

CL 1483

Plafoniera 4 luci con calotta in PMMA opal diffusore. Fregio in sandylex pearl, versione con decoro nei colori: reddish e darkgray.

4 light ceiling lamp in pearl white PMMA. Texture available in: reddish or darkgray sandylex.



41

94



GEMMA

design by Romeo Guaricci

CL 1484

Plafoniera 3 luci con calotta in PMMA opal diffusore. Fregio in sandylex pearl.

3 light ceiling lamp in pearl white PMMA.

15

∅ 51 cm



H 20 cm

Attacco E27
Lampadine: 3 x 42 W max - E27 HG

E27 screw
Bulbs: 3 x 42 W max - E27 HGS



CL 1485

Plafoniera 3 luci con calotta in PMMA opal diffusore. Fregio in sandylex pearl. Versione con decoro nei colori: reddish e darkgray.

3 light ceiling lamp in pearl white PMMA. Texture available in: reddish or darkgray sandylex.

41 94



GEMMA

design by Romeo Guaricci

CL 1486

Plafoniera 2 luci con calotta in PMMA opal diffusore. Fregio in sandylex pearl.

2 light ceiling lamp in pearl white PMMA.

15

∅ 43 cm



H 18 cm

Attacco E27
Lampadine: 2 x 42 W max - E27 HG

E27 screw.
Bulbs: 2 x 42 W max - E27 HGS



CL 1487

Plafoniera 2 luci con calotta in PMMA opal diffusore. Fregio in sandylex pearl. Versione con decoro nei colori: reddish e darkgray.

2 light ceiling lamp in pearl white PMMA. Texture available in: reddish or darkgray sandylex.

41 94



ARALIA

design by UTE



ARALIA

design by UTE

12 51 88 98



55



58



53 91



Ø 73 cm



H 40 cm

Attacco E27. Filo L. 160 cm.
Lampadine: 1 x 70 W max - E27 HGS

E27 screw. Wire length 160 cm.
Bulbs: 1 x 70 W max - E27 HGS



Sospensione in metacrilato disponibile nei colori:
Methacrylate suspension lamp available in:

CL 572 satinato, rosso, spectrall e fumé.
opaline white, red, spectrall and, smoked grey. 12 51 88 98

CL 612 cromolite 55

CL 573 texturgold 58

CL 863 decoro nuance nei colori: rosso e grigio.
Natural opal version available in: red or grey. 53 91



Ø 55 cm



H 32 cm

Attacco E27. Filo L. 160 cm.
Lampadine: 1 x 70 W max - E27 HGS

E27 screw. Wire length 160 cm.
Bulbs: 1 x 70 W max - E27 HGS



Sospensione in metacrilato disponibile nei colori:
Methacrylate suspension lamp available in:

CL 570 satinato, rosso, spectrall e fumé.
opaline white, red, spectral and, smoked grey. 12 51 88 98

CL 611 cromolite 55

CL 571 texturgold 58

CL 862 decoro nuance nei colori: rosso e grigio.
Natural opal version available in: red or grey. 53 91

ARALIA

design by UTE

CL 574

Plafoniera in metacrilato disponibile nei colori: satinato, rosso, spectrall e fumé.

Methacrylate ceiling lamp available in: opaline white, red, cromolite, spectrall and smoked grey.

12 51 88 98

Ø 53 cm



H 23 cm

Attacco E27.
Lampadine: 1 x 42 W max - E27 HGS

E27 screw.
Bulbs: 1 x 42 W max - E27 HGS



CL 613

Plafoniera in metacrilato disponibile nel colore: cromolite.

Methacrylate ceiling lamp available in: cromolite.

55



CL 575

Plafoniera in metacrilato disponibile nel colore: texturgold.

Methacrylate ceiling lamp available in: texturgold.

58



CL 864 nuance

Plafoniera in metacrilato disponibile con decoro nuance nei colori rosso e grigio.

Methacrylate ceiling lamp. Natural opal version in red and grey.

53 91



CIGNO XXL

design by Romeo Guaricci

CL1424

Sospensione 2 luci in metacrilato disponibile nei colori: satinato, spectrall e fumé.

2 light methacrylate suspension lamp available in: opaline white, spectrall and smoked grey.

12 88 98

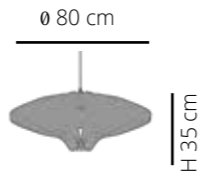

Attacco E27. Filo L 160 cm.
Lampadine: 2 x 53 W max - E27 HGS

E27 screw. Wire length 160 cm.
Bulbs: 2 x 53 W max - E27 HGS



CL 1425

Sospensione 2 luci in metacrilato disponibile nel colore: Texture gold.

2 light methacrylate suspension lamp available in: Texture gold.

58



CIGNO

design by Romeo Guaricci

CL 1410

Sospensione in metacrilato disponibile nei colori: satinato, spectrall e fumé.

Methacrylate suspension lamp available in: opaline white, spectrall and smoked grey.

12 88 98

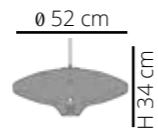

Attacco E27. Filo L 160 cm
Lampadine: 1 x 42 W max - E27 HGS

E27 screw. Wire length 160 cm.
Bulbs: 1 x 42 W max - E27 HGS



CL 1411

Sospensione in metacrilato disponibile nel colore: Texture gold.

Methacrylate suspension lamp available in: Texture gold.

58



CIGNO

design by Romeo Guaricci

CL 1412

Plafoniera in metacrilato disponibile nei colori satinato, spectrall e fumé.

Methacrylate ceiling lamp available in: opaline white, spectrall and smoked grey.

12 88 98

Ø 52 cm



H 34 cm

Attacco E27.

Lampadine: 1 x 42 W max - E27 HGS

E27 screw.

Bulbs: 1 x 42 W max - E27 HGS



CL 1413

Plafoniera in metacrilato disponibile nel colore TexturGold.

Methacrylate ceiling lamp available in: TexturGold.

58



AMARILLI

design by UTE

CL 481

Sospensione in metacrilato disponibile nei colori: trasparente, satinato, rosso, spectrall e fumé.

Methacrylate suspension lamp available in: transparent, opaline white, red, spectrall and smoked.

11 12 51 88 98

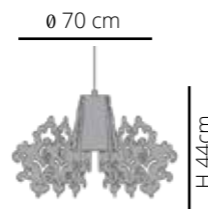

Attacco E27. Filo L. 160 cm.
Lampadine: 1 x 70 W max - E27 HGS

E27 screw. Wire length 160 cm.
Bulbs: 1 x 70 W max - E27 HGS



CL 482

Sospensione in metacrilato disponibile nel colore: texturgold.

Methacrylate suspension lamp available in: texturgold.

58



CL 607

Sospensione in metacrilato disponibile nel colore: cromolite.

Methacrylate suspension lamp available in: cromolite.

55



AMARILLI

design by UTE

CL 485

Lampada da tavolo in metacrilato disponibile nei colori: trasparente, satinato, rosso, cromolite, spectrall, fumé e texturgold.

Methacrylate table lamp available in: transparent, opaline white, red, cromolite, spectrall, smoked grey and texture gold.

11 12 51 88 98

L 22 cm



H 28 cm

Attacco E27
Lampadine: 1 x 70 W max - E27 HGS

E27 screw.
Bulbs: 1 x 70 W max - E27 HGS



CL 608

Lampada da tavolo in metacrilato disponibile nel colore: cromolite.

Methacrylate table lamp available in: cromolite.

55



CL 486

Lampada da tavolo in metacrilato disponibile nel colore: TexturGold.

Methacrylate table lamp available in: TexturGold.

58



ANTHEA

design by UTE

CL 476

Applique in metacrilato disponibile nei colori: trasparente, satinato, rosso, spectrall e fumé.

Methacrylate wall lamp available in: transparent, opaline white, red, spectrall and smoked grey.

11 12 51 88 98



L 24 cm



H 32 cm

Attacco E27
Lampadine: 1 x 70 W max - E27 HGS

E27 screw
Bulbs: 1 x 70 W max-E27 HGS

CL 477

Applique in metacrilato disponibile nel colore: texturgold.

Methacrylate wall lamp available in: texturgold.

58



CL 609

Applique in metacrilato disponibile nel colore: cromolite.

Methacrylate wall lamp available in: cromolite.

55

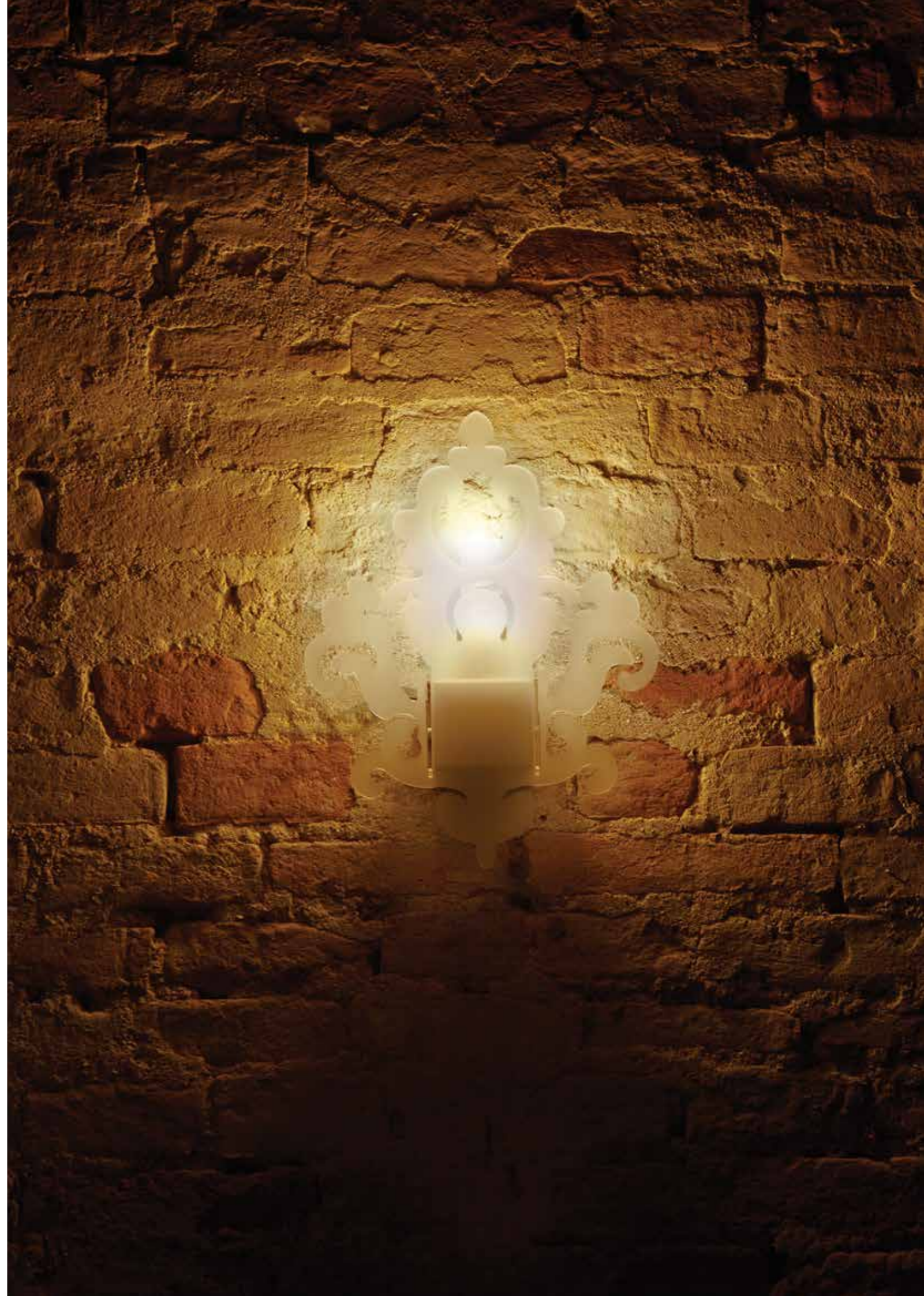

BEA MAXI

design by UTE



BEA

design by UTE





12 51 98 88

55



58



53 91

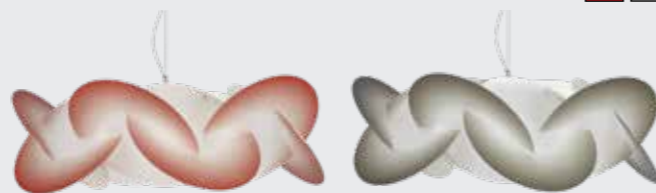

Ø 90 cm



Attacco E27.
Filo L. 160 cm.
Lampadine: 3 x 53 W max - E27 HGS

E27 screw.
Wire length 160 cm.
Bulbs: 3 x 53 W max - E27 HGS

Sospensione 3 luci in metacrilato disponibile nei colori:
3 light methacrylate suspension lamp available in:

CL 526 satinato, rosso, fumé e spectrall .
opaline white, red, smoked grey and spectral. 12 51 98 88

CL 617 cromolite 55

CL 527 texturgold 58

CL 875 decoro nuance nei colori: rosso e grigio.
Natural opal version available in: red or grey. 53 91



Ø 54 cm



Attacco E27.
Filo L. 160 cm.
Lampadina: 1 x 53 W max - E27 HGS

E27 screw.
Wire length 160 cm.
Bulb: 1 x 53 W max - E27 HGS

Sospensione in metacrilato disponibile nei colori:
Methacrylate suspension lamp available in:

CL 178 satinato, rosso, fumé e spectrall .
opaline white, red, smoked grey and spectral. 12 51 98 88

CL 616 cromolite 55

CL 179 textur gold 58

CL 874 decoro nuance nei colori: rosso e grigio.
Natural opal version available in: red or grey. 53 91

BELLATRIX MAXI

design by UTE



BELLATRIX

design by UTE



BELLATRIX



12 51 98 88

55



58



BELLATRIX MAXI

design by UTE



Ø 116 cm



H 33 cm



Attacco E27.
Filo L.160 cm.
Lampadine: 3 x 53 W max - E27 HGS

E27 screw.
Wire length 160 cm.
Bulbs: 3 x 53 W max - E27 HGS

Sospensione a 3 luci in metacrilato disponibile nei colori:
3 light methacrylate suspension lamp available in:

CL 524 satinato, rosso, fumé e spectrall.
opaline white, red, smoked grey and spectrall. 12 51 98 88

CL 620 cromolite 55

CL 525 texturgold 58

BELLATRIX

design by Roberto Giacomucci



Ø 90 cm



H 26 cm



Attacco E27.
Filo L.160 cm.
Lampadine: 1 x 70 W max - E27 HGS

E27 screw.
Wire length 160 cm.
Bulbs: 1 x 70 W max - E27 HGS

Sospensione in metacrilato disponibile nei colori:
Methacrylate suspension lamp available in:

CL 451 satinato, rosso, fumé e spectrall.
opaline white, red, smoked grey and spectrall. 12 51 98 88

CL 619 cromolite 55

CL 416 texturgold 58

BIBANG

design by UTE



BIBANG MAXI

design by Roberto Giacomucci



12 51 98 88



55



58

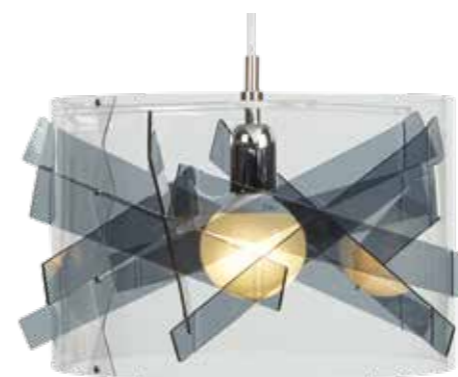

∅ 40 cm



H 25 cm



Attacco E27. Filo L.160 cm.
Lampadine: 1 x 70 W max - E27 HGS

E27 screw. Wire length 160 cm.
Bulbs: 1 x 70 W max - E27 HGS

Sospensione con paralume cilindrico in policarbonato trasparente ed elementi ad incastro in metacrilato nei colori:

Transparent polycarbonate suspension lamp with cylindrical lampshade. Interlocking elements available in:

CL 418 satinato, rosso, fumé e spectrall.
opaline white, red, smoked grey and spectrall.

12 51 98 88

CL 621 cromolite

55

CL 417 texturgold

58

BIBANG MAXI

design by Roberto Giacomucci

∅ 75 cm



H 42 cm



Attacco E27. Filo L.160 cm.
Lampadine: 3 x 53 W max - E27 HGS

E27 screw. Wire length 160 cm.
Bulbs: 3 x 53 W max - E27 HGS



Sospensione 3 luci con paralume cilindrico in policarbonato trasparente ed elementi ad incastro in metacrilato nei colori:

3 light transparent polycarbonate suspension lamp with cylindrical lampshade. Interlocking elements available in:

CL 528 satinato, rosso, fumé e spectrall.
opaline white, red, smoked grey and spectrall.

12 51 98 88

CL 622 cromolite

55

CL 529 texturgold

58

KARTIKA

design by UTE

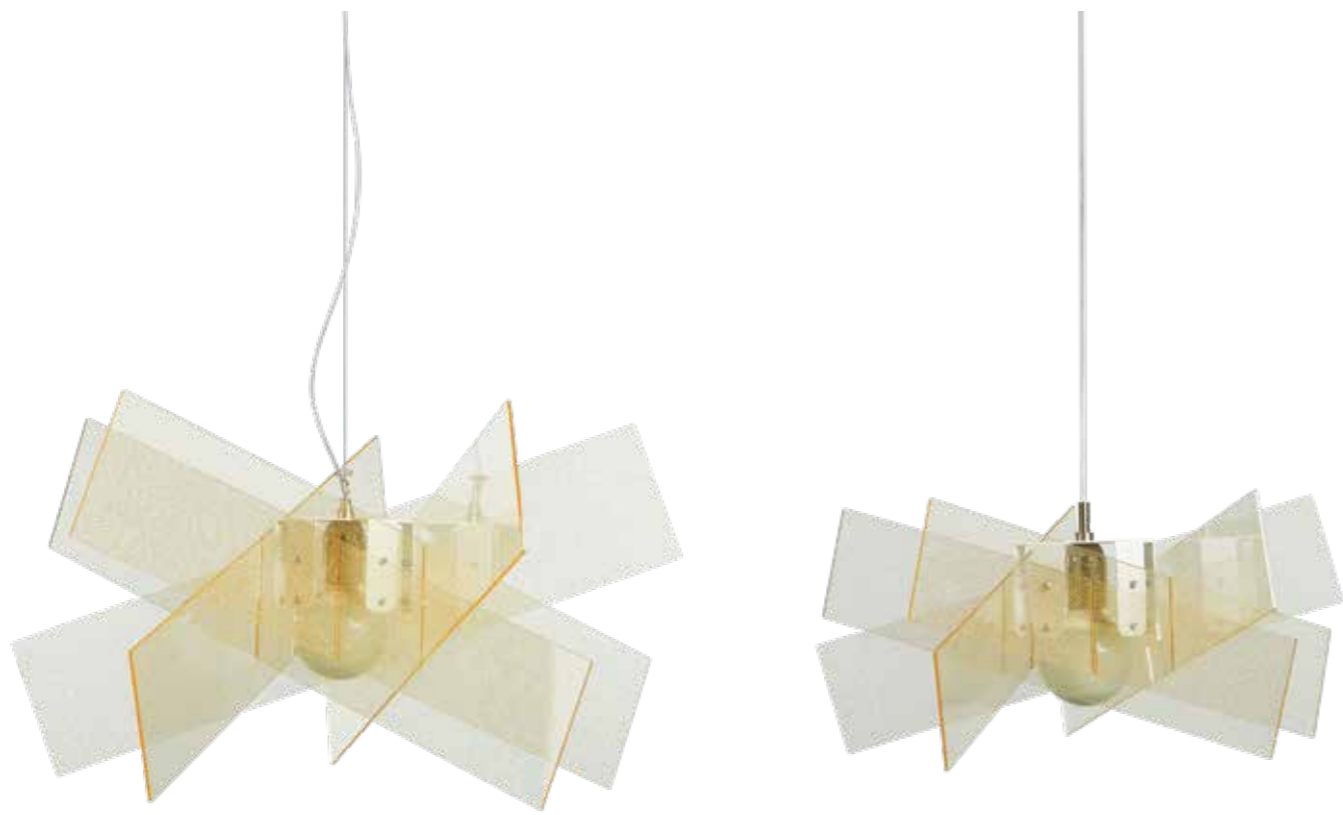

12 51 98 88

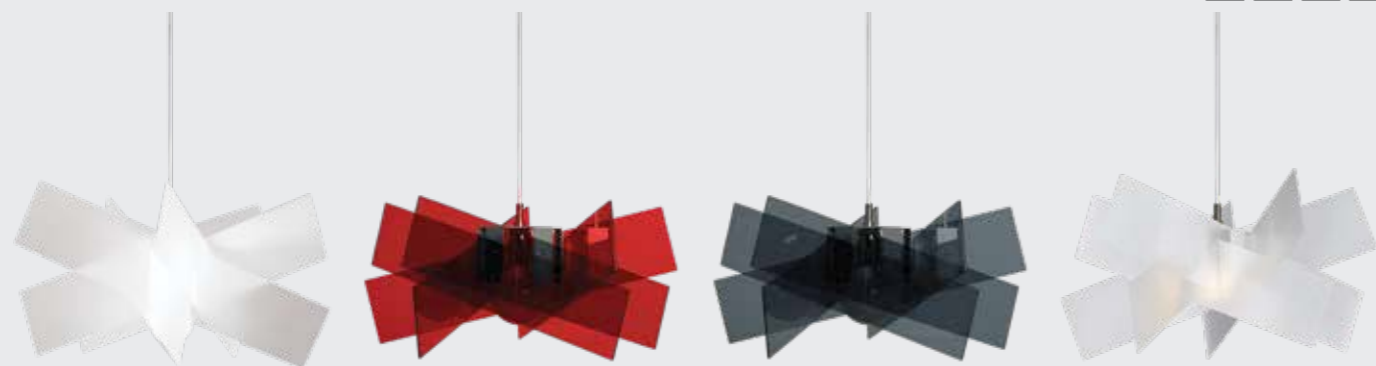

∅ 53 cm

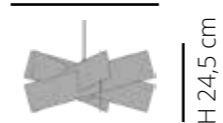

H 24,5 cm

Attacco E27. Filo L.160 cm.
Lampadine: 1 x 70 W max - E27 HGS

E27 screw. Wire length 160 cm.
Bulbs: 1 x 70 W max - E27 HGS

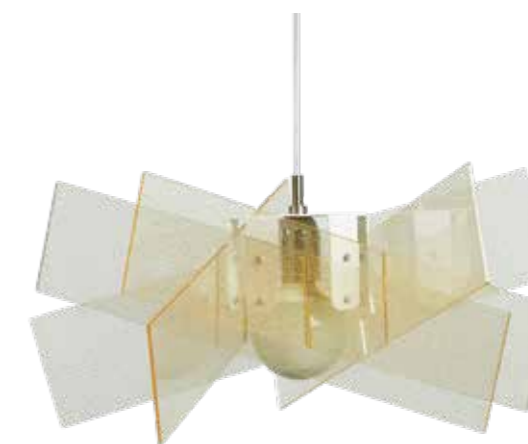

Sospensione in metacrilato disponibile nei colori:
Methacrylate suspension lamp available in:

- CL 137 satinato, rosso, fumé and spectrall. opaline white, red, smoked grey and spectrall. 12 51 98 88
- CL 636 cromolite. 55
- CL 138 texturgold. 58
- CL 865 decoro nuance nei colori: rosso e grigio. natural opal version available in: red or grey. 53 91

55



58



∅ 69 cm

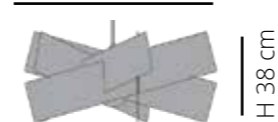

H 38 cm

Attacco E27. Filo L.160 cm.
Lampadine: 1 x 70 W max - E27 HGS

E27 screw. Wire length 160 cm.
Bulbs: 1 x 70 W max - E27 HGS

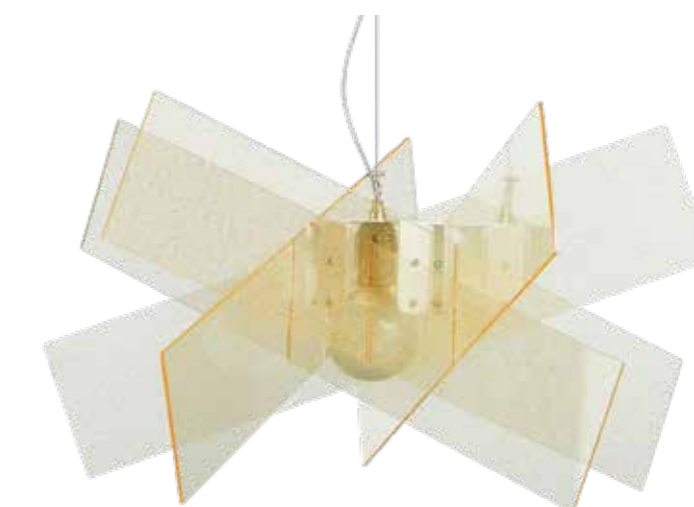

Sospensione in metacrilato disponibile nei colori:
Methacrylate suspension lamp available in:

- CL 139 satinato, rosso, fumé and spectrall. opaline white, red, smoked grey and spectrall. 12 51 98 88
- CL 637 cromolite. 55
- CL 140 texturgold. 58
- CL 866 decoro nuance nei colori: rosso e grigio. natural opal version available in: red or grey. 53 91

53 91

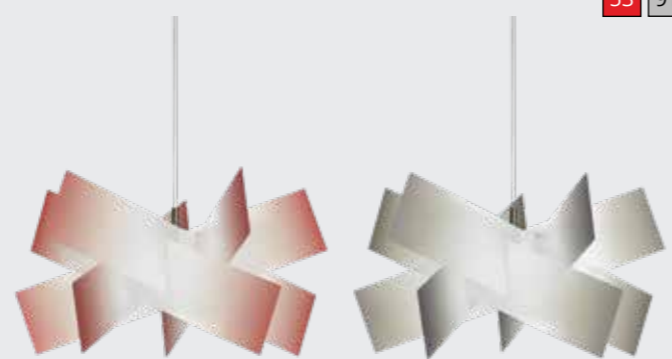

ARFO'

design by **Alberto Vallesi**

CL 1491

*Sospensione in legno massello.
Disponibile nel colore noce.*

*Suspension lamp with wooden structure.
Available in: walnut.*

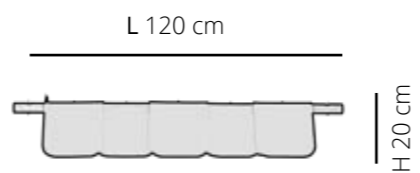

*Alimentata a strip led IP 20 - 24V - TOT. 20 W - 2400 Lumen.
Luce calda 3000 K + 5 %*

*Strip led IP 20 - 24V - TOT. 20 W - 2400 Lumen.
Warm light 3000 K + 5%*



ARFO'

design by **Alberto Vallesi**

CL 1491

*Sospensione in legno massello.
Disponibile nel colore frassino.*

*Suspension lamp with wooden structure.
Available in: ash wood.*

70

L 120 cm

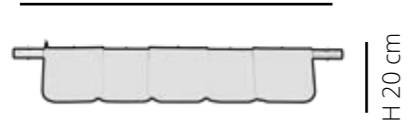

*Alimentata a strip led IP 20 - 24V - TOT. 20 W - 2400 Lumen.
Luce calda 3000 K + 5 %*

*Strip led IP 20 - 24V - TOT. 20 W - 2400 Lumen.
Warm light 3000 K + 5%*



DUO

design by **Walter Sbicca**

CL 1495

Sospensione 2 luci con paralumi in sandylex pearl.

2 light suspension lamp with pearl white sandylex lampshades.

15



CL 1496

Sospensione 2 luci con paralumi in sandylex, texture rosso e grigio.
(Possibile a richiesta unico colore)

2 light suspension lamp. Lampshades available in: red and grey.
(only one color upon request)

99

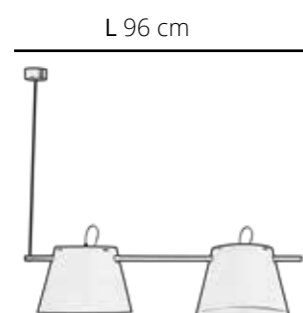

Attacco E 27 Filo L. 160 cm.
Lampadine : 2 X 53 W max - E 27 HGS

E 27 screw Wire length. 160 cm.
Bulbs : 2 X 53 W max - E 27 HGS



TRIO

design by **Walter Sbicca**

CL 1493

Sospensione 3 luci con paralumi in sandylex pearl.

3 light suspension lamp with pearl white sandylex lampshades.

15



CL 1492

Sospensione 3 luci con paralumi in sandylex, texture rosso, grigio e verde.
(Possibile a richiesta unico colore)

3 light suspension lamp. Lampshades available in: red, grey and green.
(only one color upon request)

99



L 150 cm



H 118 cm

Attacco E 27 Filo L. 160 cm.
Lampadine : 3 X 53 W max - E 27 HGS

E 27 screw Wire length. 160 cm.
Bulbs : 3 X 53 W max - E 27 HGS



RICCIOLO

design by UTE

CL 909

Sospensione in metacrilato, disponibile nei colori: trasparente, satinato, fumé e spectrall.

Methacrylate suspension lamp available in: transparent, opaline white, smoked grey and spectrall.

11 12 98 88



CL 656

Sospensione in metacrilato, disponibile nel colore: cromolite.

Methacrylate suspension lamp available in: cromolite.

55



CL 926

Sospensione in metacrilato, disponibile nel colore: texturgold.

Methacrylate suspension lamp available in: texturgold.

58



CL 877

Sospensione in metacrilato, disponibile nella versione natural opal con decoro nuance nei colori: rosso e grigio.

Methacrylate suspension lamp.
Natural opal version available in: red or grey.

53 91



Ø 75 cm

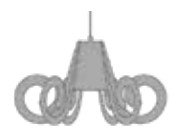

H 43 cm

Attacco E27. Filo L. 160 cm.
Lampadine: 1 x 70 W max - E27 HGS

E27 screw. Wire length cm 160.
Bulbs: 1 x 70 W max - E27 HGS

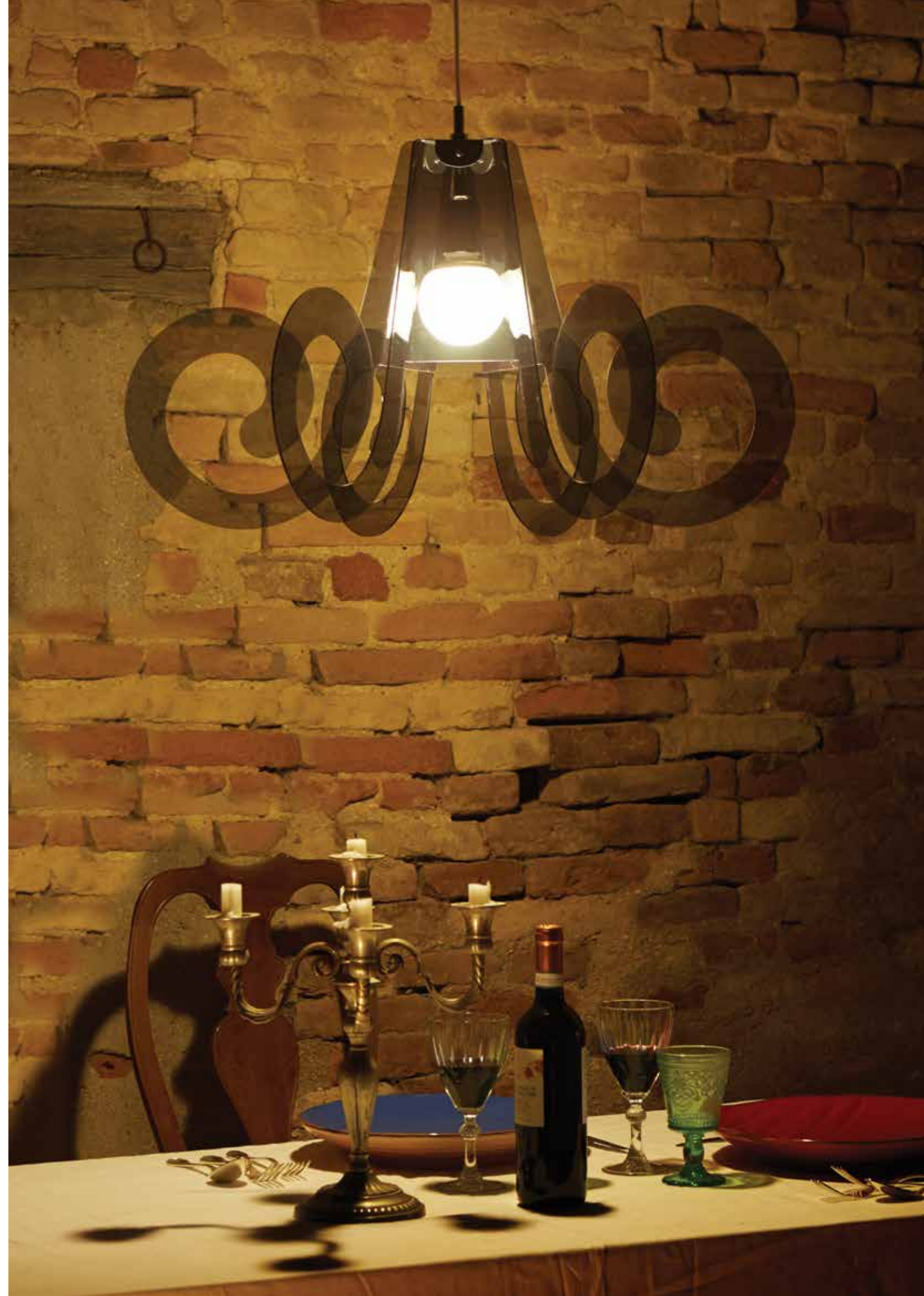

RICCIOLINO

design by UTE

CL 908

Sospensione in metacrilato, disponibile nei colori: trasparente, satinato, fumé e spectrall.

Methacrylate suspension lamp available in: transparent, opaline white, smoked grey and spectrall.

11 12 98 88



CL 655

Sospensione in metacrilato, disponibile nel colore: cromolite.

Methacrylate suspension lamp available in: cromolite.

55



CL 925

Sospensione in metacrilato, disponibile nel colore: texturgold.

Methacrylate suspension lamp available in: texturgold.

58



CL 876

Sospensione in metacrilato, disponibile nella versione natural opal con decoro nuance nei colori: rosso e grigio.

Methacrylate suspension lamp. Natural opal version available in: red or grey.

53 91



Ø 55 cm

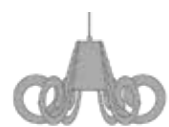

H 32 cm



Attacco E27. Filo L. 160 cm.
Lampadine : 1 x 70 W max - E27 HGS

E27 screw. Wire length cm 160.
Bulbs: 1 x 70 W max - E27 HGS





LAMPADA DELL'AVVOCATO

design by **Walter Sbicca**

CL 1478

Lampada da tavolo: struttura in MDF laccato nero, paralume Sandylex con stampa.

Table lamp. MDF structure coated black. Lampshade in printed Sandylex

Ø 35 cm



H 40 cm

15



CL 1479

Lampada da tavolo: struttura in MDF laccato nero paralume in Sandylex, rivestimento in tessuto con cerniera lampo, disponibile nei decori: feltro grigio, tessuto intrecciato e pizzo nero.

Table lamp. MDF structure coated black. Lampshade in braided Sandylex. Texture coating with zip available in grey felt material, braided net or black lace.

L 35 cm



H 40 cm

91

67

05



KIRA MINI

design by Romeo Guaricci

CL 1443

Lampada in PMMA cristalopal. Base in acciaio con fondo in metacrilato nero.

PMMA cristalopal table lamp. Base in steel.

14



Alimentata Strip led -IP20 - 12V - Tot.12 W - Luce naturale 4000 K + 5%, 15 IM/led. F.

Wiring strip led. IP20 - 12V - Tot.12W. 4000 K + 5%, 15 IM/led.



KIRA SMALL

design by Romeo Guaricci

CL 1442

Lampada in PMMA cristalopal . Base in acciaio con fondo in metacrilato nero.

PMMA cristalopal lamp. Base in steel.

14



Alimentata Strip led -IP20 - 12V - Tot.24 W - Luce naturale 4000 K + 5%, 15 IM/led.

Wiring strip led. IP20 - 12V - Tot.24W. 4000 K + 5%, 15 IM/led.



KIRA LARGE

design by Romeo Guaricci

CL 1441

Lampada in PMMA cristalopal. Base in acciaio con fondo in metacrilato nero.

PMMA cristalopal floor lamp. Base in steel.

14



Alimentata strip led -IP20 - 12V - Tot.60 W - Luce naturale 4000 K + 5%, 15 IM/led.

Wiring strip led. IP20 - 12V - Tot.60W. 4000 K + 5%, 15 IM/led.



SIGNORAPINA

design by UTE

CL1453

Lampada da tavolo in sandylex pearl. Base e struttura in metallo verniciato. Disco copribase in acrilik cromo e oro.

Table lamp in pearl sandylex. Base in chrome and gold acrilik.

55 57

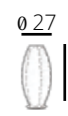

Attacco E14
2 Lampadine: 2 x 42 W max-E14 FBT

E14 screw.
Bulbs: 2 x 42 W max E14 FBT



SIGNORAPINA LARGE

design by UTE

CL1451

*Piantana in sandylex pearl. Base e struttura in metallo verniciato.
Disco copribase in acirek cromo e oro.*

Floor lamp in pearl sandylex. Base in chrome and gold acirek.

55 57

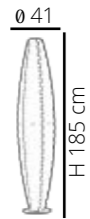

Attacco E27

Lampadine: 4 x 42 W max-E27 HGS

E27 screw

Bulbs: 4 x 42 W max E27 HGS



SIGNORAPINA MEDIUM

design by UTE

CL1452

*Piantana in sandylex pearl. Base e struttura in metallo verniciato.
Disco copribase in acrilik cromo e oro.*

Floor lamp in pearl sandylex. Base in chrome and gold acrilik.

55 57

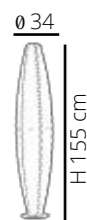

Attacco E27
3 Lampadine: 3 x 53 W max-E27 HGS

E27 screw
Bulbs: 3 x 53 W max E27 HGS



DIVA

design by UTE

CL 435

Lampada da terra 2 luci in polipropilene bianco perla.

Floor lamp in white pearl polypropylene.

10

∅ 37



H 140 cm

Attacco E27

Lampadine: 2 x 70 W max - E27 HGS

E27 screw.

Bulbs: 2 x 70 W max - E27 HGS



STONE

design by Nicola Cerasa

CL 1520

Lampada da terra con ripiani portaoggetti.
Struttura in metallo elaborato verniciato bianco.
Paralume in sandylex pearl particolari in PMMA satinato.

Floor lamp with shelves.
White coated metal structure,
sandylex pearl lampshade, opaline white PMMA details.

15

Ø 46 cm



H 180 cm

Attacco E 27
Lampadine 2 x 70 W max - E27 HGS

E27 screw
Bulbs: 2 x 70 w max - E27 HGS



CL 1521

Lampada da terra con ripiani portaoggetti.
Struttura in metallo elaborato verniciato bianco,
Paralume in sandylex con texture, decoro grigio,
particolari in PMMA satinato.

Floor lamp with shelves.
White coated metal structure,
grey sandylex texture lampshade, opaline white PMMA details.

91

Ø 46 cm



H 180 cm

Attacco E 27
Lampadine 2 x 70 W max - E27 HGS

E27 screw
Bulbs: 2 x 70 w max - E27 HGS



TRILLY

design by UTE

CL 551

Sospensione realizzata in materiale acrilico disponibile nei colori: trasparente, verde, rosso, blu, fumé.

Suspension lamp in acrylic material available in: transparent, green, red, blue and smoked grey.



∅ 20 cm

Attacco E27. Filo L.160 cm.
Lampadine: 1 x 70 W max - E27 HGS



H 21 cm

E27 screw. Wire L 160 cm.
Bulbs: 1 x 70 W max - E27 HGS



CL 552

Sospensione realizzata in materiale acrilico disponibile nei colori: trasparente, verde, rosso, blu, fumé.

Suspension lamp in acrylic material available in: transparent, green, red, blue and smoked grey.



∅ 20 cm

Attacco E27. Filo L.160 cm.
Lampadine: 1 x 70 W max - E27 HGS



H 21 cm

E27 screw. Wire L 160 cm.
Bulbs: 2 x 53 W max - E27 HGS



CL 553

Sospensione realizzata in materiale acrilico disponibile nei colori: trasparente, verde, rosso, blu, fumé.

Suspension lamp in acrylic material available in: transparent, green, red, blue and smoked grey.



∅ 20 cm

Attacco E27. Filo L.160 cm.
Lampadine: 1 x 70 W max - E27 HGS



H 21 cm

E27 screw. Wire L 160 cm.
Bulbs: 3 x 53 W max - E27 HGS



TATA

design by UTE

CL 550

Lampada da tavolo realizzata in materiale acrilico. Disponibile nei colori: trasparente, verde, rosso, blu e fumé.

Table lamp in acrylic material. Available in: transparent, green, red, blue and smoked grey.

11 20 51 61 91

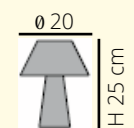

Lampadina inclusa: 1 x 5W led G9

Bulb included: 1 x 5W led G9



TATA

design by UTE

CL 1584

Lampada da tavolo in polimero acrilico, disponibile nei colori: trasparente, verde, rosso, blu e fumè. Ricaricabile, cavo micro USB.

Table lamp made in acrylic. Available in the following colours: transparent, green, red, blue, fumè. Rechargeable. Micro USB wire.

11 20 51 61 91

Ø 20
H 25 cm
Led 4 W luce calda 3000K
Led 4W warm light 3000k.



GINGI

design by **Walter Sbicca**

CL 1671

Lampada da tavolo realizzata in sandylex e base in PMMA. disponibile nei colori : bianco pearl, con texture verde, rosso , blu e grigio. Cavo ricarica micro USB incluso. (materiali Plastici riciclabili)

Table lamp made of sandylex, PMMA base. Available in the following colours: pearl white, green, red, blue and grey textures. Micro USB charging cable included. (recyclable plastics)

15 20 51 61 94

L 19

Led 4 W luce calda 3000K



H 40 cm

Led 4W warm light 3000k.



Personalizzato
Customized



TRACK

design by UTE

TRACK 9 - CL 382

Sospensione in metacrilato effetto satinato. Spessore 15 mm.

Methacrylate suspension lamp in opaline white effect color.
Thickness: 15 mm.

12

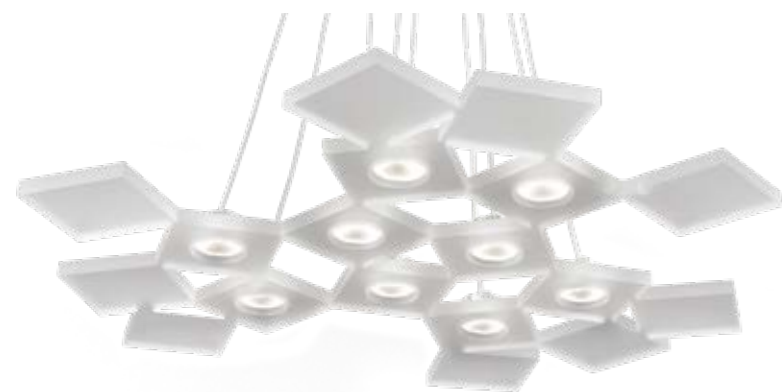

L 67 cm



P 72 cm



Fili L.200 cm.
Cablaggio LED 36W - 220 V
Lumen 3.780 °K LED 3000

Wire length 200 cm.
Wiring LED 36W - 220 V
Lumen 3.780 °K LED 3000

TRACK 8 - CL 380

Sospensione in metacrilato effetto satinato. Spessore 15 mm.

Methacrylate suspension lamp in opaline white effect color.
Thickness: 15 mm.

12



L 91 cm



P 32 cm



Fili L.200 cm.
Cablaggio LED 32W - 220 V
Lumen 3.360 °K LED 3000

Wire length 200 cm.
Wiring LED 32W - 220 V
Lumen 3.360 °K LED 3000

TRACK 3 - CL 364

Sospensione in metacrilato effetto satinato. Spessore 15 mm.

Methacrylate suspension lamp in opaline white effect color.
Thickness: 15 mm.

12



L 27 cm



P 23 cm



Fili L.200 cm.
Cablaggio LED 12W - 220 V
Lumen 1.260 °K LED 3000

Wire length 200 cm.
Wiring LED 12W - 220 V
Lumen 1.260 °K LED 3000



CL 384

Sospensione in metacrilato effetto satinato. Spessore 15mm.

Methacrylate suspension lamp in opaline white. Thickness 15 mm.

12

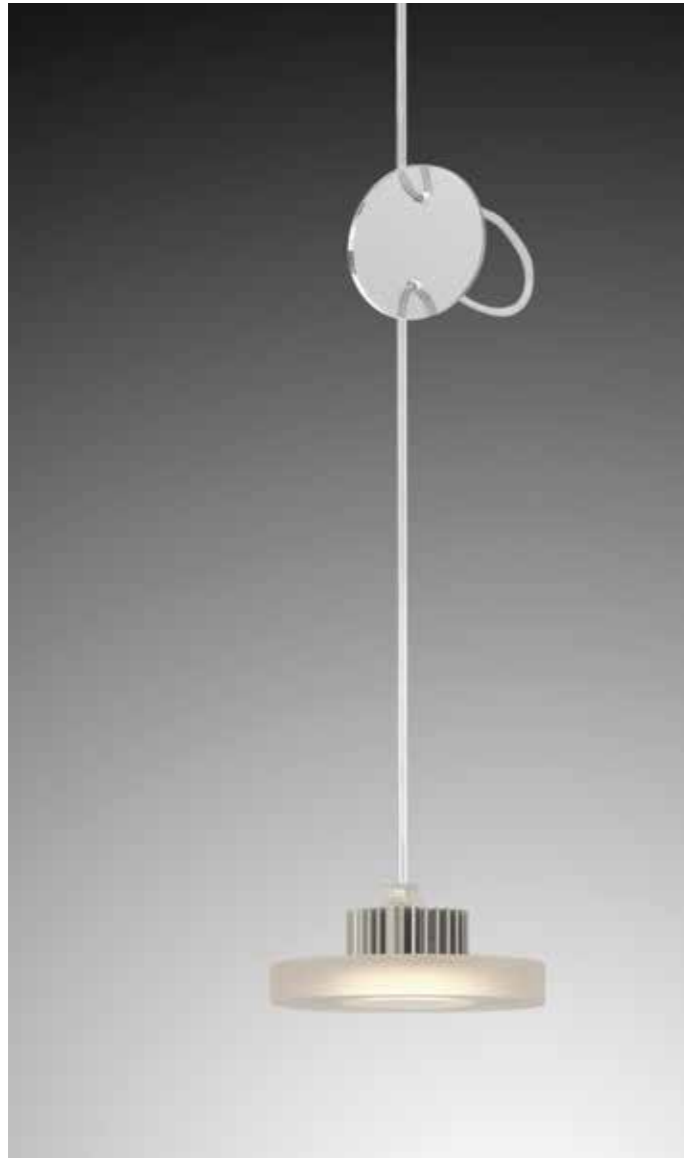

∅ 10 cm



H 4,5 cm

Filo L. 200 cm.
Cablaggio LED 4W - 220 V
Lumen 420 °K LED 3000

Wire length 200cm.
Wiring LED 4W - 220 V
Lumen 420 °K LED 3000



CL 143

Sospensione di grandi dimensioni a 3 luci. Semisfera in metacrilato opal diffusore spessore 8 mm.

3 light suspension lamp. Opal diffuser methacrylate dome 8mm thickness.

10



CL 144

Sospensione di grandi dimensioni a 3 luci. semisfera in metacrilato opal diffusore spessore 8 mm.
Colori a scelta

3 light suspension lamp. Opal diffuser methacrylate dome 8mm thickness.

10



∅ 143 cm

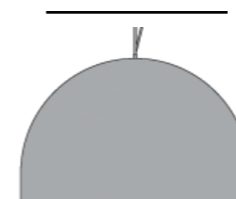

H 70 cm

Attacco E27
Filo e cavi di sospensione in acciaio cm 200.
Lampadine: 3 x 53 W max - E27 HGS

E27 screw
Wire and steel suspension cables length 200 cm.
Bulbs: 3 x 53 W max - E27 HGS



BRUNELLA

design by UTE

CL 395

Sospensione 3 luci. Cupola in metacrilato diffusore, disco in metacrilato satinato.

3 light suspension lamp. Methacrylate lampshade with opaline white methacrylate disc.

12



Ø 62 cm



H 42 cm

Attacco E27. Filo L.160 cm.
Lampadine: 3 x 53 W max - E27 HGS

E27 screw. Wire length 160 cm.
Bulbs: 3 x 53 W max - E27 HGS



COSCIENZA

design by **Walter Sbicca**

CL 1498

Sospensione con soggetto in resina laccato oro.
(possibili altri colori del soggetto su richiesta)

Suspension lamp. Gold lacquered character.
(character available in other colours upon request)

57

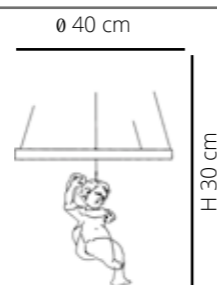

Alimentata a strip led - IP 20 - 24 V - TOT.10 W - 2650 Lumen.
Luce calda 3000K +5%

Strip led - IP 20 - 24 V - TOT.10 W - 2650 Lumen. Warm light 3000K +5%

CL 1499

Sospensione con soggetto in resina laccato rosso.
(possibili altri colori del soggetto su richiesta)

Suspension lamp. Red lacquered character.
(character available in other colours upon request)

51

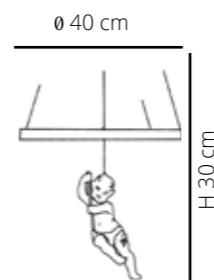

Alimentata a strip led - IP 20 - 24 V - TOT.10 W - 2650 Lumen.
Luce calda 3000K +5%

Strip led - IP 20 - 24 V - TOT.10 W - 2650 Lumen. Warm light 3000K +5%



CAMILLA

design by Walter Sbicca

CL1490

*Applique in metacrilato sp. 8 mm e paralume in sandylex.
Disponibile nei colori: bianco e nero.*

*Methacrylate wall lamp thickness 8 mm with sandylex lampshade
available in white and black.*

10 05

P 19,5 cm



L 15 cm



Lampadine: 1 x 70 W max - E27 HGS

Bulbs: 1 x 70 W max - E27 HGS

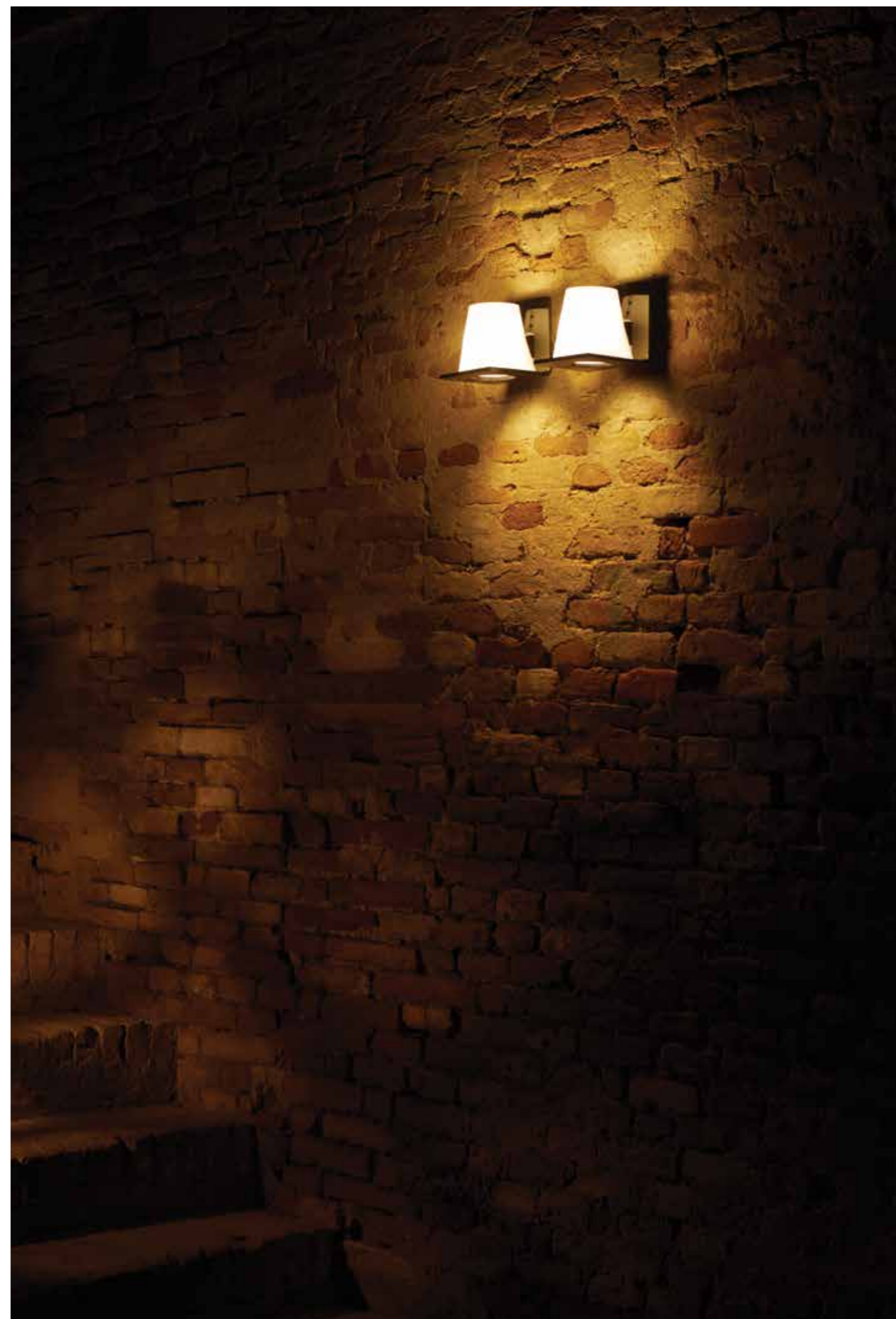

CAMILLATRIS

design by **Walter Sbicca**

CL1579

*Applique 3 luci in metacrilato sp.8 mm .
Colori Bianco e Nero*

*3 lights applique. Methacrylate structure. Thickness 8mm.
Available in white and black.*

10 05

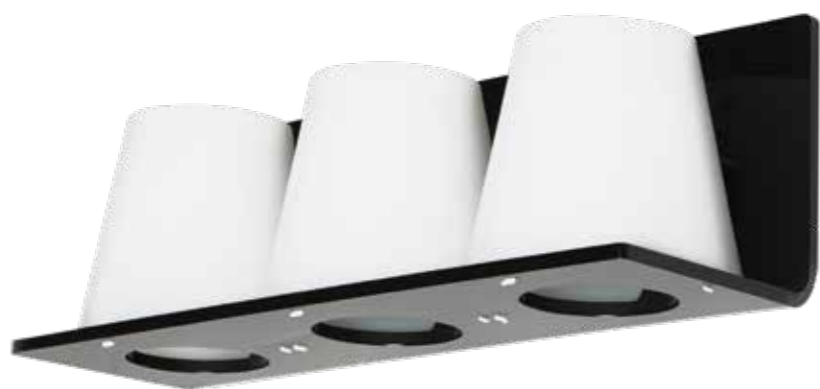

P 20 cm

L 44 cm



H 16 cm



H 16 cm

Lampadine: 3 x 70 W max - E27 HGS

Bulbs: 3 x 70 W max - E27 HGS

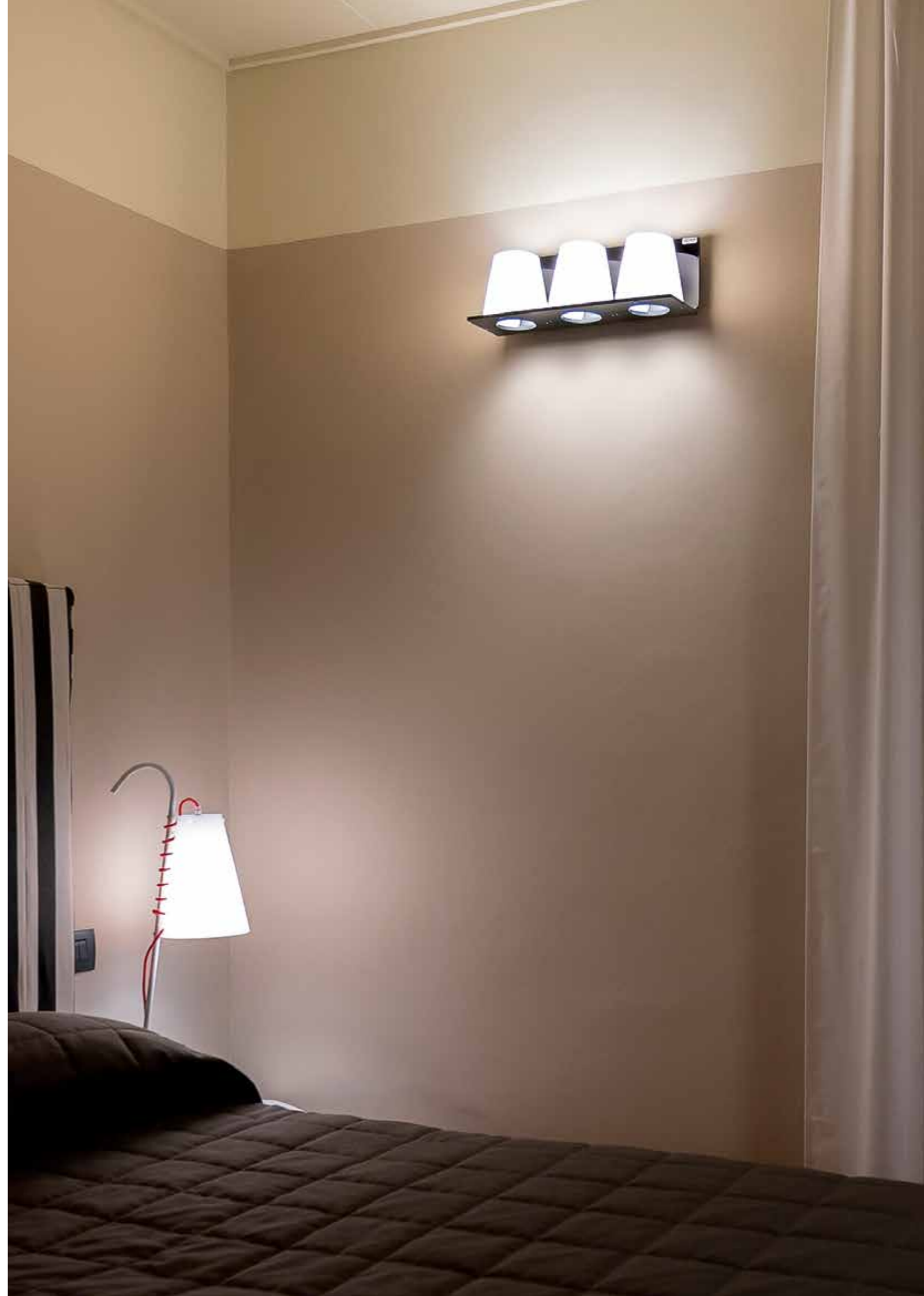

EARLY

CL 1518

Lampada da tavolo touch multifunzione in ABS + gomma colore bianco.

Multifunctional touch table lamp in ABS + white rubber.

10

L 14,5 cm
H 33 cm



SNAKE

CL1519

Lampada da tavolo o portatile in ABS + gomma colore bianco.

Touch table lamp in ABS + white rubber.

10

L 10 cm
H 30 cm



TRUCIOLO

design by UTE

CL 190

Lampada da tavolo con paralume cilindrico in metacrilato opal diffusore. Base in metacrilato disponibile nei colori: nero, trasparente, satinato.

Table lamp. Methacrylate lampshade, opal diffuser shade. Methacrylate base available in: transparent, black and opaline white.

05 11 12

∅ 26,5



H 60 cm

Attacco E27.
Lampadine: 1 x 70 W max - E27 HGS

E27 screw.
Bulbs: 1 x 70 W max - E27 HGS



TRUCIOLO

design by UTE

CL 189

Lampada da tavolo con paralume cilindrico in metacrilato opal diffusore. Base in metacrilato disponibile nei colori: nero, trasparente, satinato.

Table lamp. Methacrylate lampshade, opal diffuser shade. Methacrylate base available in: transparent, black and opaline white.

05 11 12



Ø 18,5



H 36 cm

Attacco E27.
Lampadine: 1 x 70 W max - E27 HGS

E27 screw.
Bulbs: 1 x 70 W max - E27 HGS



ROSA

design by UTE

CL 478

Plafoniera con paralume a corolla in policarbonato antiriflesso disponibile nel colore bianco.

Non-glare white polycarbonate ceiling lamp.



10

∅ 55 cm



H 23 cm

Attacco E27
Lampadine: 1 x 42 W max - E27 HGS

E27 screw
Bulbs: 1 x 42 W max - E27 HGS

CL 479

Plafoniera con paralume a corolla in policarbonato antiriflesso disponibile nel colore bianco.

Non-glare white polycarbonate ceiling lamp.



10

∅ 40 cm



H 19 cm

Attacco E27
Lampadine: 1 x 42 W max - E27 HGS

E27 screw
Bulbs: 1 x 42 W max - E27 HGS



DIDODADO

design by UTE

CL 444

Sospensione con paralume in PMMA disponibile nei seguenti colori: satinato, spectrall e fumè.

Suspension lamp with PMMA lampshade available in: opaline white, spectrall, smoked grey.

12 88 98



CL 625

cromolite

55



CL 409

texturgold

58



L 11 cm



H 18 cm

Attacco E27. Filo L. 160 cm.
Lampadine: 1 x 42 W max - E27 HGS

E27 screw. Wire length 160 cm.
Bulbs: 1 x 42 W max - E27 HGS



DIDODADO

design by UTE

CL 447

Sospensione barra a quattro elementi con paralume in PMMA nei seguenti colori: satinato, spectrall e fumè.

Suspension lamp with PMMA lampshade available in: opaline white, spectrall, smoked grey.

12 88 98



CL 628

cromolite

55



CL 412

texturgold

58

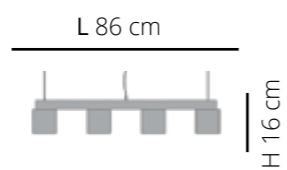

Attacco E27. Filo L.160 cm.
Lampadine: 4 x 42 W max - E27 HGS

E27 screw. Wire length 160 cm.
Bulbs: 4 x 42 W max - E27 HGS



DIDODADO

design by UTE

CL 446

Applique con paralume in PMMA disponibile nei seguenti colori: satinato, spectrall e fumè.

Wall lamp with PMMA lampshade available in: opaline white, spectrall, smoked grey.

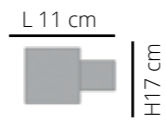

Attacco E27.
Lampadine: 1 x 42 W max - E27 HGS

E27 screw.
Bulbs: 1 x 42 W max - E27 HGS

12 88 98



CL 411

Applique con paralume in PMMA disponibile nel colore: texturgold.

Wall lamp with PMMA lampshade available in: texturgold.

58



CL 627

Applique con paralume in PMMA disponibile nel colore: cromolite.

Wall lamp with PMMA lampshade available in: cromolite.

55



DIDODADO

design by UTE

CL 448

Plafoniera barra a quattro elementi con paralume in PMMA disponibile nei seguenti colori: satinato, spectrall e fumè.

Ceiling lamp with PMMA lampshade available in: opaline white, spectrall, smoked grey.

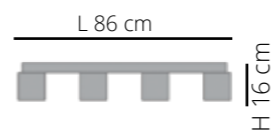

Attacco E27.
Lampadine: 4 x 42 W max - E27 HGS

E27 screw.
Bulbs: 4 x 42 W max - E27 HGS

12 88 98



CL 413

Plafoniera barra a quattro elementi con paralume in PMMA disponibile nel colore: texturgold.

Ceiling lamp with PMMA lampshade available in: texturgold.

58



CL 629

Plafoniera barra a quattro elementi con paralume in PMMA disponibile nel colore: cromolite.

Ceiling lamp with PMMA lampshade available in: cromolite.

55



CL 445

Spot con paralume in PMMA disponibile nei seguenti colori:
satinato, spectrall e fumè.

Spot with PMMA lampshade available in:
opaline white, spectrall, smoked grey.

12 88 98

L 11 cm



H 17 cm

Attacco E27.
Lampadine: 1 x 42 W max - E27 HGS

E27 screw.
Bulbs: 1 x 42 W max - E27 HGS



CL 410

Spot con paralume in PMMA disponibile nel colore: texturgold.

Spot with PMMA lampshade available in: texturgold.

58



CL 626

Spot con paralume in PMMA disponibile nel colore: cromolite.

Spot with PMMA lampshade available in: cromolite.

55



UBI

design by UTE

CL 389 FIORI - CL 390 FILI

Spot con cilindro in metacrilato rasterizzato. Supporto in acciaio con trattamento galvanico. Disponibile nelle versioni: cromo, oro e rame.

Spot with raster methacrylate cylinder. Steel fitting. Texture available in: chrome, gold and copper.

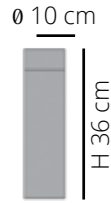

Attacco : GX53-1
Lampadine 1 X 9 W - GX 53 - 1 LED
Lampadine 1 X 9 W - GX 53 - 1 FB

GX53-1 screw
Bulbs 1 X 9 W - GX 53 - 1 LED
Bulbs 1 X 9 W - GX 53 - 1 FB

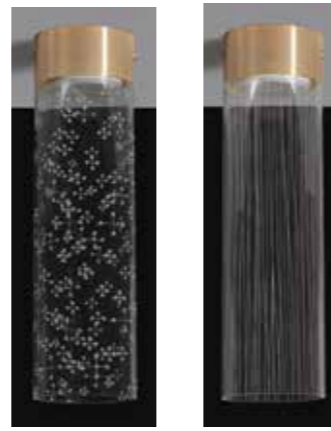

34 35 36

CL 387 FIORI - CL 388 FILI

Spot con cilindro in metacrilato rasterizzato. Supporto in acciaio con trattamento galvanico. Disponibile nelle versioni: cromo, oro e rame.

Spot with raster methacrylate cylinder. Steel fitting. Texture available in: chrome, gold and copper.

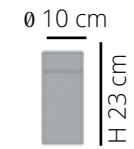

Attacco : GX53-1
Lampadine 1 X 9 W - GX 53 - 1 LED
Lampadine 1 X 9 W - GX 53 - 1 FB

GX53-1 screw
Bulbs 1 X 9 W - GX 53 - 1 LED
Bulbs 1 X 9 W - GX 53 - 1 FB

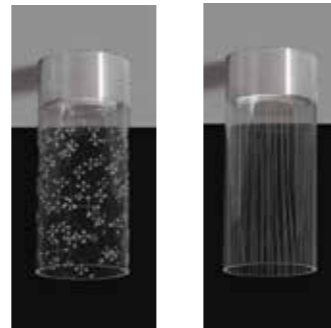

34 35 36

CL 385 FIORI - CL 386 FILI

Spot con cilindro in metacrilato rasterizzato. Supporto in acciaio con trattamento galvanico. Disponibile nelle versioni: cromo, oro e rame.

Spot with raster methacrylate cylinder. Steel fitting. Texture available in: chrome, gold and copper.

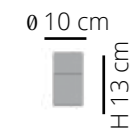

Attacco : GX53-1 Lampadine 1 X 9 W - GX 53 - 1 LED
Lampadine 1 X 7 W - GX 53 - 1 FB

GX53-1 Screw
Bulbs 1 X 9 W - GX 53 - 1 LED
Bulbs 1 X 9 W - GX 53 - 1 FB

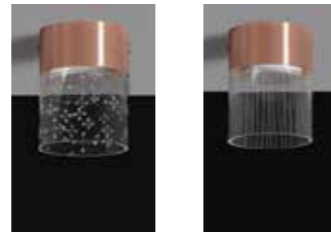

34 35 36



UBI

design by UTE

CL 391 - FIORI

Sospensione con cilindro in metacrilato rasterizzato. Supporto in acciaio con trattamento galvanico. Disponibile nelle versioni: cromo, oro e rame.

Suspension lamp with raster methacrylate cylinder. Steel fitting. Texture available in: chrome, gold and copper.

34 35 36



CL 392 - FILI

Sospensione con cilindro in metacrilato rasterizzato. Supporto in acciaio con trattamento galvanico. Disponibile nelle versioni: cromo, oro e rame.

Suspension lamp with raster methacrylate cylinder. Steel fitting. Texture available in: chrome, gold and copper.

34 35 36

Attacco : GX53-1
Lampadine 1 X 9 W - GX 53 - 1 LED
Lampadine 1 X 7 W - GX 53 - 1 FB
(1 lampadina inclusa.)

GX53-1 screw
Bulbs 1 X 9 W - GX 53 - 1 LED
Bulbs 1 X 7 W - GX 53 - 1 FB D
(1 Bulb included.)





ENJOY
the little
★
THINGS

La Fabbrica
ARTISANALE

La Fabbrica
ARTISANALE

CL 1512

Sospensione rettangolare 2 luci in acrilico. Disponibile nei colori kristalcromo, kristaloro e kristalbronzo.

Rectangular suspension lamp with 2 lights available in: kristalchrome, kristalgold and kristalbronze.

55 57 59

L 60 cm
P 20 cm

Attacco : GX 53-1.
Lampadine: 2 X 9 W max- GX 53-1 led

Screw: GX 53-1
Bulbs: 2 X 9 W max- GX 53-1 led

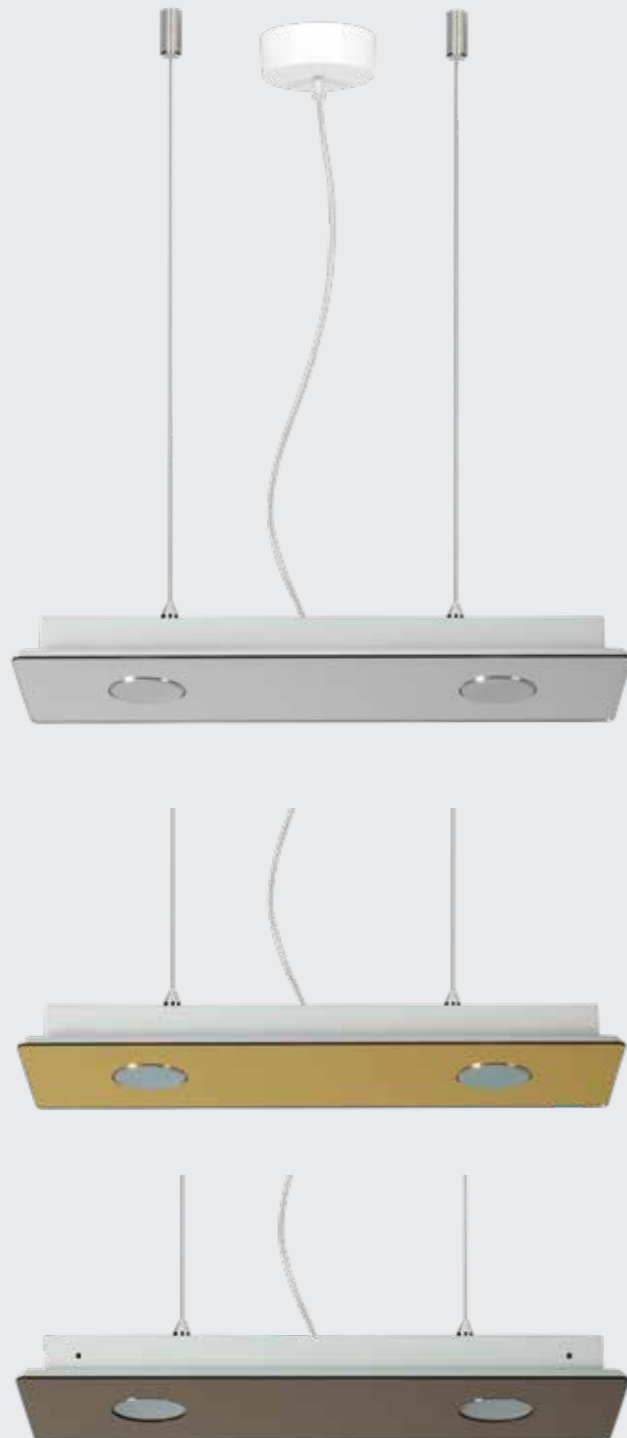

CL 1513

Sospensione rettangolare 3 luci in acrilico. Disponibile nei colori kristalcromo, kristaloro e kristalbronzo.

Rectangular suspension lamp with 3 lights available in: kristalchrome, kristalgold and kristalbronze.

55 57 59

L 90 cm
P 20 cm

Attacco : GX 53-1.
Lampadine: 3 X 9 W max- GX 53-1 led

Screw: GX 53-1
Bulbs: 3 X 9 W max- GX 53-1 led

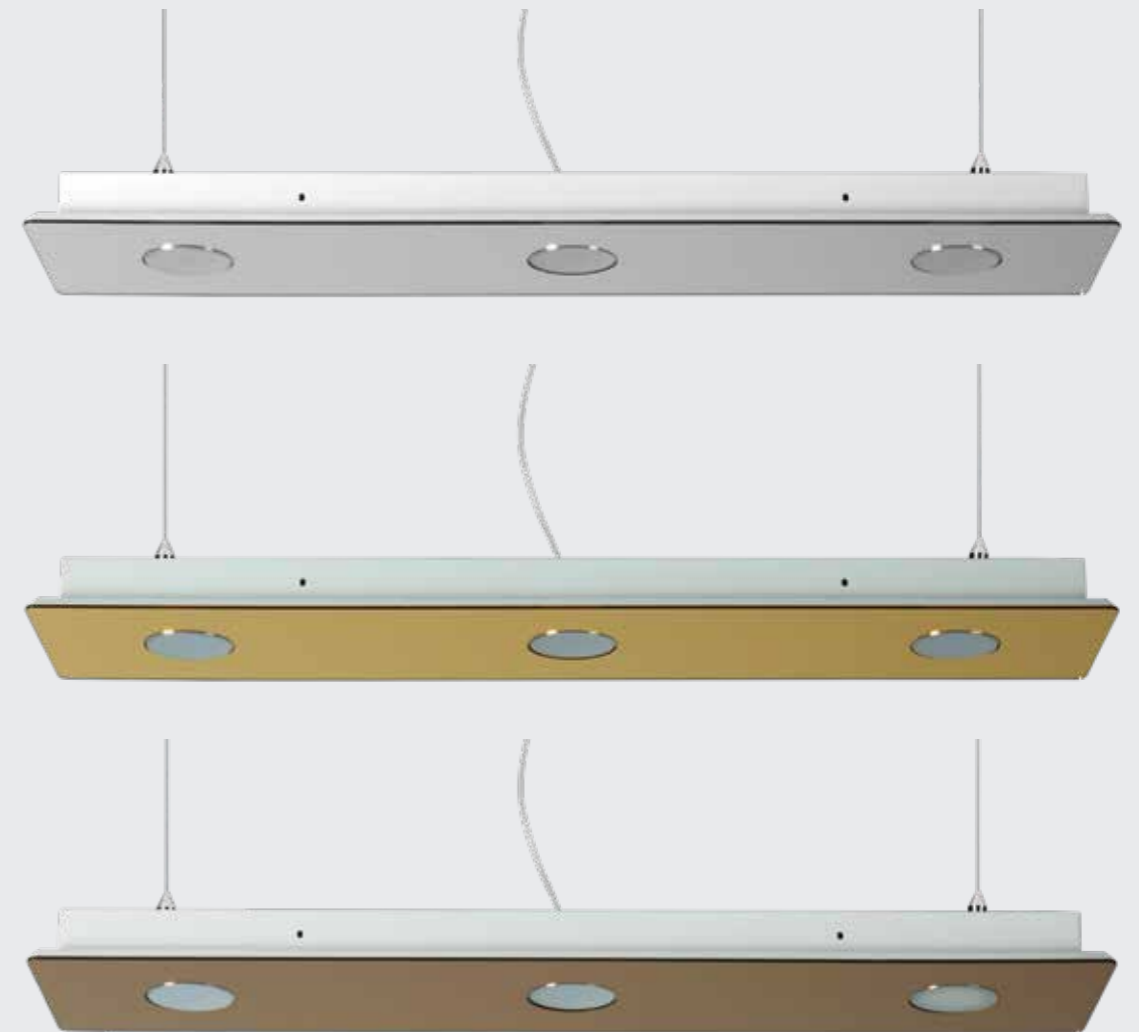

CL 1514

Sospensione rettangolare 4 luci in acrilico. Disponibile nei colori kristalcromo, kristaloro e kristalbronzo.

Rectangular suspension lamp with 4 lights available in: kristalchrome, kristalgold and kristalbronze.



Attacco : GX 53-1.
Lampadine: 4 X 9 W max- GX 53-1 led

Screw: GX 53-1
Bulbs: 4 X 9 W max- GX 53-1 led



CL 1517

Sospensione rettangolare 8 luci in acrilico. Disponibile nei colori kristalcromo, kristaloro e kristalbronzo.

Rectangular suspension lamp with 8 lights available in: kristalchrome, kristalgold and kristalbronze.

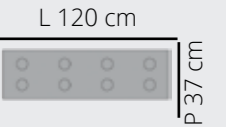

Attacco : GX 53-1.
Lampadine: 8 X 9 W max- GX 53-1 led

Screw: GX 53-1
Bulbs: 8 X 9 W max- GX 53-1 led



CL 1511

Sospensione quadrata 4 luci in acrilico. Disponibile nei colori kristalchromo, kristaloro e kristalbronzo.

Square suspension lamp with 4 lights available in: kristalchrome, kristalgold and kristalbronze.



L 40 cm



P 40 cm

Attacco : GX 53-1.
Lampadine: 4 X 9 W max- GX 53-1 led

Screw: GX 53-1
Bulbs: 4 X 9 W max- GX 53-1 led

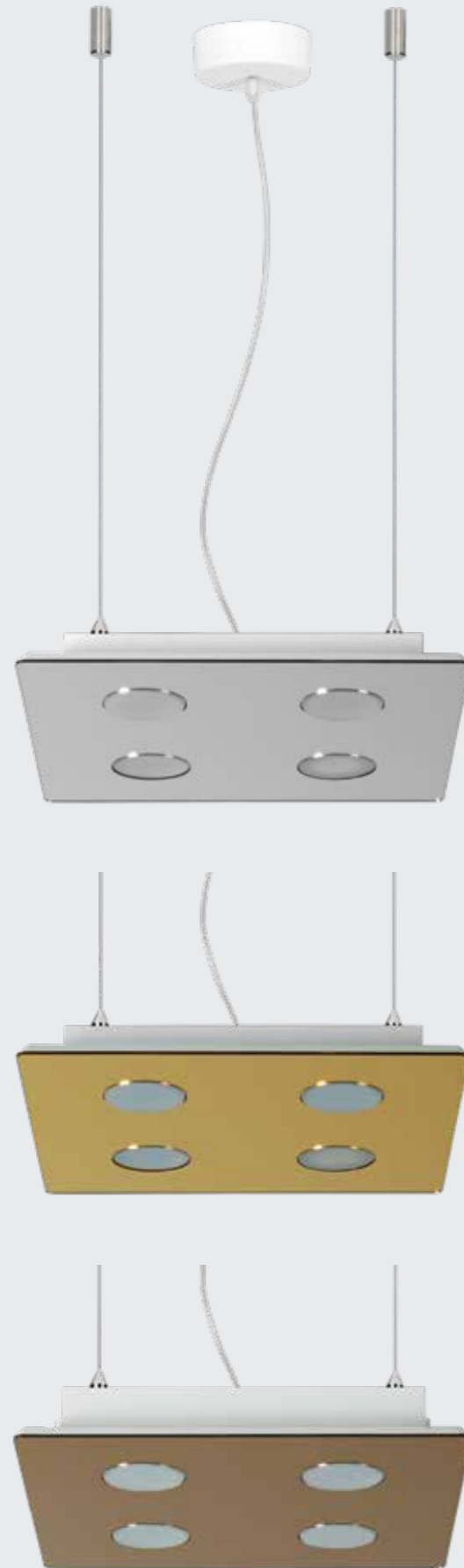

CL 1515

Sospensione quadrata 5 luci in acrilico. Disponibile nei colori kristalchromo, kristaloro e kristalbronzo.

Square suspension lamp with 5 lights available in: kristalchrome, kristalgold and kristalbronze.



L 48 cm



P 48 cm

Attacco : GX 53-1.
Lampadine: 5 X 9 W max- GX 53-1 led

Screw: GX 53-1
Bulbs: 5 X 9 W max- GX 53-1 led

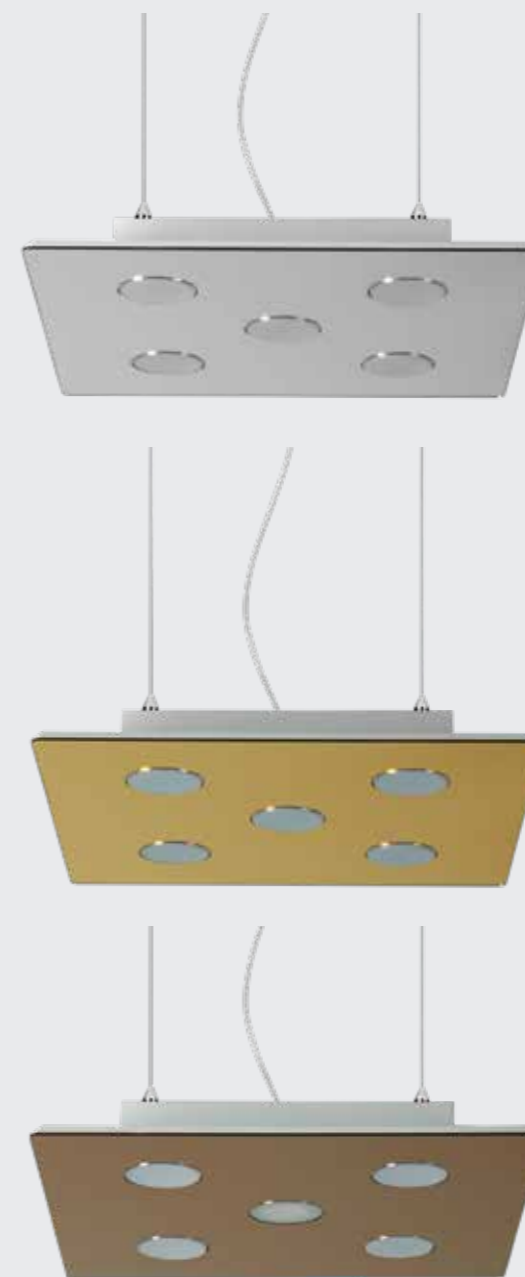

DAMA

design by UTE

CL 1516

Sospensione quadrata 6 luci in acrilico. Disponibile nei colori kristalchromo, kristaloro e kristalbronzo.

Square suspension lamp with 6 lights available in: kristalchrome, kristalgold and kristalbronze.

55 57 59

L 58 cm



Attacco : GX 53-1.
Lampadine: 6 X 9 W max- GX 53-1 led
Screw: GX 53-1
Bulbs: 6 X 9 W max- GX 53-1 led

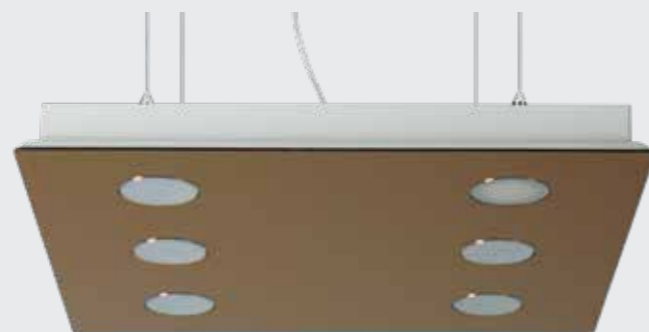
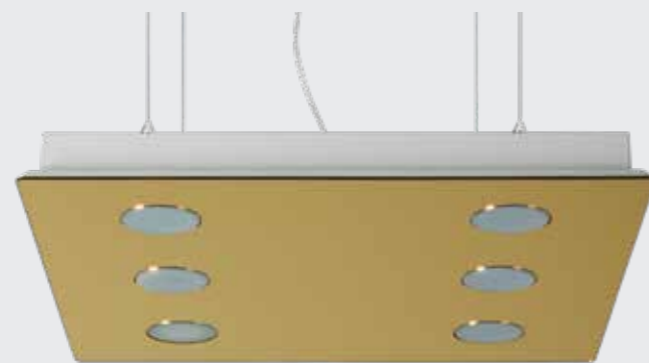



CL 1510

Applique 2 luci in acrilico. Disponibile nei colori kristalchromo, kristaloro e kristalbronz.

Wall lamp with 2 lights available in: kristalchrome, kristalgold and kristalbronz.



Attacco : GX 53-1.
Lampadine: 2 X 9 W max- GX 53-1 led
Screw: GX 53-1
Bulbs: 2 X 9 W max- GX 53-1 led

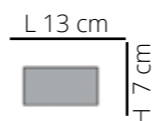

CL 1509

Applique 1 luce in acrilico. Disponibile nei colori kristalchromo, kristaloro e kristalbronz.

Wall lamp available in: kristalchrome, kristalgold and kristalbronz.



Attacco : GX 53-1.
Lampadine: 1 X 9 W max- GX 53-1 led
Screw: GX 53-1
Bulbs: 1 X 9 W max- GX 53-1 led

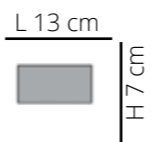

DAMA

design by UTE

CL 1508

Plafoniera rettangolare 8 luci in acrilico. Disponibile nei colori kristalchromo, kristaloro e kristalbronzo.

Rectangular ceiling lamp with 8 lights available in: kristalchrome, kristalgold and kristalbronze.

55 57 59

L 120 cm



P 33 cm

Attacco : GX 53-1.
Lampadine: 8 X 9 W max- GX 53-1 led

Screw: GX 53-1
Bulbs: 8 X 9 W max- GX 53-1 led

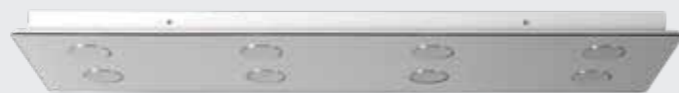

CL 1504

Plafoniera rettangolare 4 luci in acrilico. Disponibile nei colori kristalchromo, kristaloro e kristalbronzo.

Rectangular ceiling lamp with 4 lights available in: kristalchrome, kristalgold and kristalbronze.

55 57 59

L 120 cm

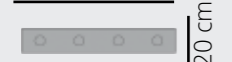

P 20 cm

Attacco : GX 53-1.
Lampadine: 4 X 9 W max- GX 53-1 led

Screw: GX 53-1
Bulbs: 4 X 9 W max- GX 53-1 led



CL 1503

Plafoniera rettangolare 3 luci in acrilico. Disponibile nei colori kristalcromo, kristaloro e kristalbronzo.

Rectangular ceiling lamp with 3 lights available in: kristalchrome, kristalgold and kristalbronze.



Attacco : GX 53-1.
Lampadine: 3 X 9 W max- GX 53-1 led
Screw: GX 53-1
Bulbs: 3 X 9 W max- GX 53-1 led

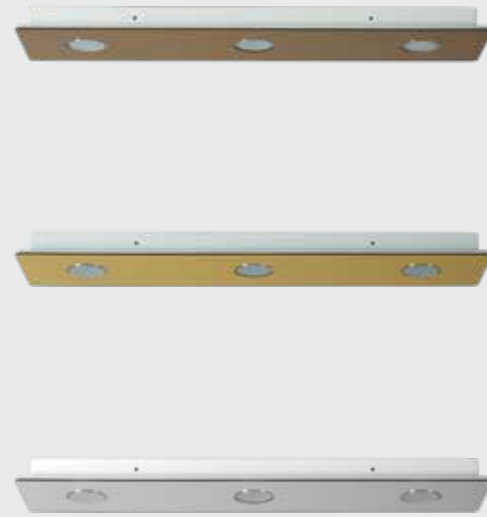

CL 1502

Plafoniera rettangolare 2 luci in acrilico. Disponibile nei colori kristalcromo, kristaloro e kristalbronzo.

Rectangular ceiling lamp with 2 lights available in: kristalchrome, kristalgold and kristalbronze.

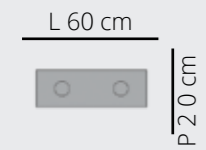

Attacco : GX 53-1.
Lampadine: 2 X 9 W max- GX 53-1 led
Screw: GX 53-1
Bulbs: 2 X 9 W max- GX 53-1 led



CL 1507

Plafoniera quadrata 4 luci in acrilico. Disponibile nei colori kristalcromo, kristaloro e kristalbronzo.

Square ceiling lamp with 4 lights available in: kristalchrome, kristalgold and kristalbronze.

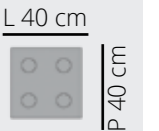

Attacco : GX 53-1.
Lampadine: 4 X 9 W max- GX 53-1 led
Screw: GX 53-1
Bulbs: 4 X 9 W max- GX 53-1 led



CL 1505

Plafoniera quadrata 5 luci in metacrilato bicolore bianco e trasparente.

Square ceiling lamp with 5 lights. Structure in bicolor methacrylate, white and transparent.

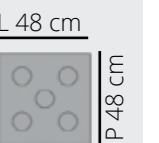

Attacco : GX 53-1.
Lampadine: 5 X 9 W max- GX 53-1 led
Screw: GX 53-1
Bulbs: 5 X 9 W max- GX 53-1 led



CL 1506

Plafoniera quadrata 6 luci in acrilico. Disponibile nei colori kristalchrome, kristaloro e kristalbronzo.

Square ceiling lamp with 6 lights available in: kristalchrome, kristalgold and kristalbronze.

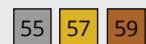

L 58 cm



P 58 cm

Attacchi GX 53-1.
Attacco : GX 53-1.
Lampadine: 6 X 9 W max- GX 53-1 led

Screw: GX 53-1
Bulbs: 6 X 9 W max- GX 53-1 led



CL 1501

Plafoniera quadrata 1 luce in acrilico. Disponibile nei colori kristalchrome, kristaloro e kristalbronzo.

Square ceiling lamp available in: kristalchrome, kristalgold and kristalbronze.



L 19 cm



P 19 cm

Attacco : GX 53-1.
Lampadine: 1 X 9 W max- GX 53-1 led

Screw: GX 53-1
Bulbs: 1 X 9 W max- GX 53-1 led



CL 1500

Spot rotondo 1 luce in acrilico. Disponibile nei colori kristalchrome, kristaloro e kristalbronzo.

Spot available in: kristalchrome, kristalgold and kristalbronze.

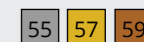

Ø18 cm



Attacco : GX 53-1.
Lampadine: 1 X 9 W max- GX 53-1 led

Screw: GX 53-1
Bulbs: 1 X 9 W max- GX 53-1 led



DOMINO

design by UTE

CL 695

Sospensione quadrata 6 luci in metacrilato bicolore bianco e trasparente.

Square suspension lamp with 6 lights. Structure in bicolor methacrylate, white and transparent.

10

L 58 cm



P 58 cm

Attacco : GX 53-1.

Lampadine: 6 X 9 W max- GX 53-1 led

Screw: GX 53-1

Bulbs: 6 X 9 W max- GX 53-1 led

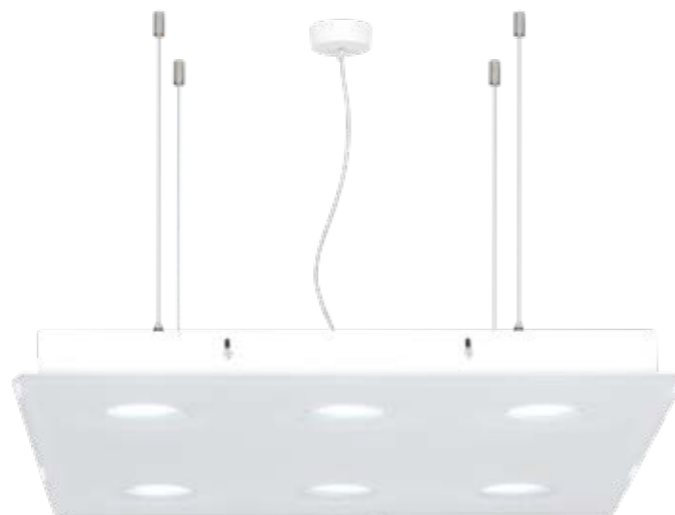

CL 599

Sospensione quadrata 5 luci in metacrilato bicolore bianco e trasparente.

Square suspension lamp with 5 lights. Structure in bicolor methacrylate, white and transparent.

10

L 48 cm

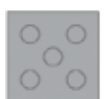

P 48 cm

Attacco : GX 53-1.

Lampadine: 5 X 9 W max- GX 53-1 led

Screw: GX 53-1

Bulbs: 5 X 9 W max- GX 53-1 led



CL 581

Sospensione quadrata 4 luci in metacrilato bicolore bianco e trasparente.

Square suspension lamp with 4 lights. Structure in bicolor methacrylate, white and transparent.

10

L 40 cm



P 40 cm

Attacco : GX 53-1.

Lampadine: 4 X 9 W max- GX 53-1 led

Screw: GX 53-1

Bulbs: 4 X 9 W max- GX 53-1 led



DOMINO

design by UTE

CL 697

Sospensione rettangolare 8 luci in metacrilato bicolore bianco e trasparente.

Rectangular suspension lamp with 8 lights. Structure in bicolor methacrylate, white and transparent.

10

L 120 cm

P 35 cm

Attacco : GX 53-1.

Lampadine: 8 X 9 W max- GX 53-1 led

Screw: GX 53-1

Bulbs: 8 X 9 W max- GX 53-1 led



CL 580

Sospensione rettangolare 4 luci in metacrilato bicolore bianco e trasparente.

Rectangular suspension lamp with 4 lights. Structure in bicolor methacrylate, white and transparent.

10

L 120 cm

P 20 cm

Attacco : GX 53-1.

Lampadine: 4 X 9 W max- GX 53-1 led

Screw: GX 53-1

Bulbs: 4 X 9 W max- GX 53-1 led



CL 579

Sospensione rettangolare 3 luci in metacrilato bicolore bianco e trasparente.

Rectangular suspension lamp with 3 lights. Structure in bicolor methacrylate, white and transparent.

10

L 90 cm

P 20 cm

Attacco : GX 53-1.

Lampadine: 3 X 9 W max- GX 53-1 led

Screw: GX 53-1

Bulbs: 3 X 9 W max- GX 53-1 led



CL 578

Sospensione rettangolare 2 luci in metacrilato bicolore bianco e trasparente.

Rectangular suspension lamp with 2 lights. Structure in bicolor methacrylate, white and transparent.

10

L 60 cm

P 20 cm

Attacco : GX 53-1.

Lampadine: 2 X 9 W max- GX 53-1 led

Screw: GX 53-1

Bulbs: 2 X 9 W max- GX 53-1 led



DOMINO

design by UTE

CL 587

Applique 2 luci in metacrilato bicolore bianco e trasparente.
Struttura in metallo bianco verniciato.

Wall lamp with 2 lights. Structure in bicolor methacrylate,
white and transparent.

10



Attacco : GX 53-1.
Lampadine: 2 X 9 W max- GX 53-1 led

Screw: GX 53-1
Bulbs: 2 X 9 W max- GX 53-1 led

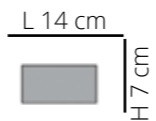

CL 577

Applique in metacrilato bicolore bianco e trasparente.
Struttura in metallo bianco verniciato.

Wall lamp. Structure in bicolor methacrylate,
white and transparent.

10



Attacco : GX 53-1.
Lampadine: 1 X 9 W max- GX 53-1 led

Screw: GX 53-1
Bulbs: 1 X 9 W max- GX 53-1 led

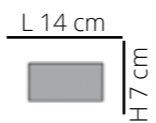

DOMINO

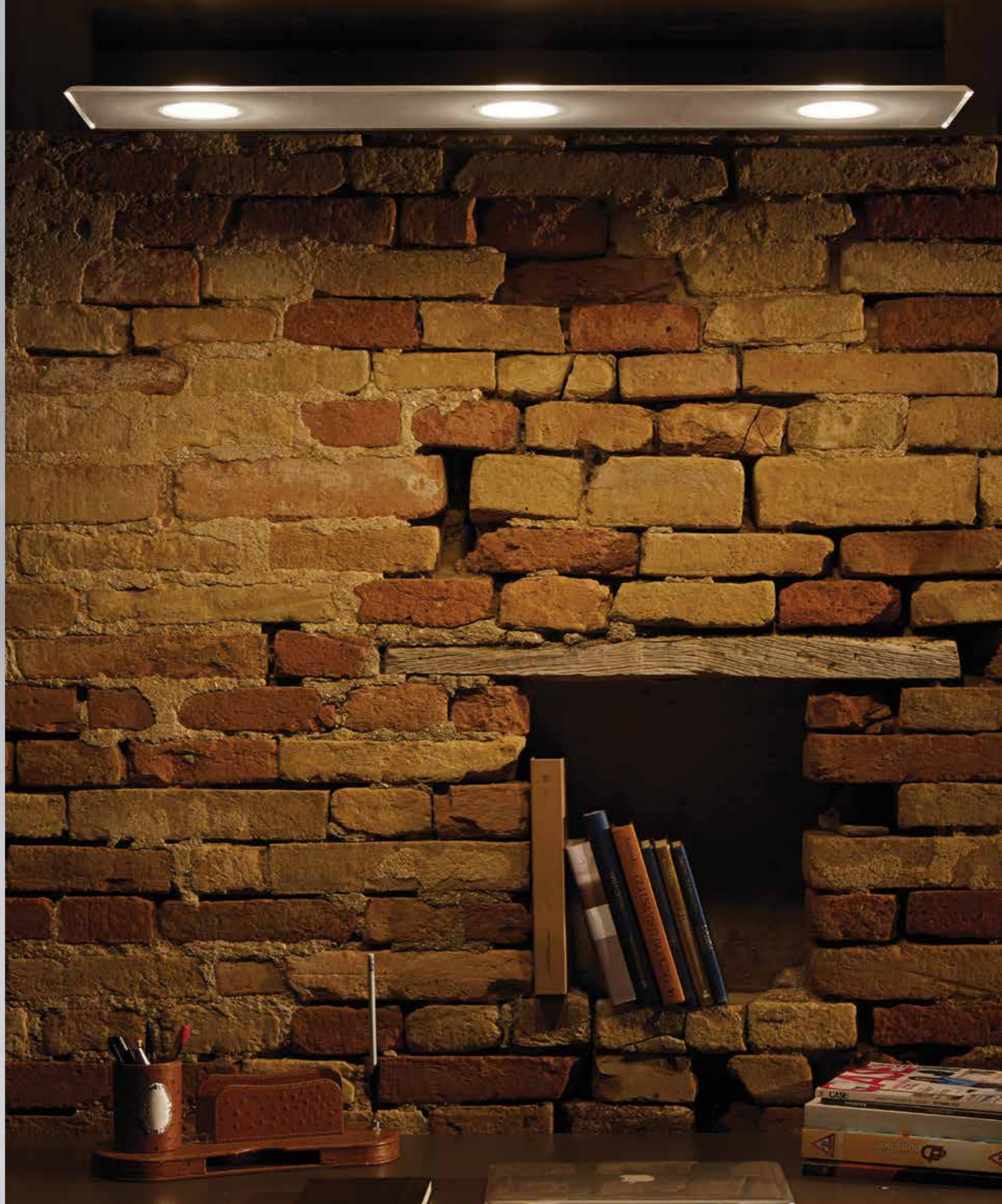

CL 698

Plafoniera rettangolare 8 luci in metacrilato bicolore bianco e trasparente.

Square ceiling lamp with 8 lights. Structure in bicolor methacrylate, white and transparent.

10

L 120 cm
P 35 cm
Attacco : GX 53-1.
Lampadine: 8 X 9 W max- GX 53-1 led
Screw: GX 53-1
Bulbs: 8 X 9 W max- GX 53-1 led



CL 585

Plafoniera rettangolare 3 luci in metacrilato bicolore bianco e trasparente.

Rectangular ceiling lamp with 3 lights. Structure in bicolor methacrylate, white and transparent

10

L 90 cm
P 20 cm
Attacco : GX 53-1.
Lampadine: 3 X 9 W max- GX 53-1 led
Screw: GX 53-1
Bulbs: 3 X 9 W max- GX 53-1 led



CL 586

Plafoniera rettangolare 4 luci in metacrilato bicolore bianco e trasparente.

Rectangular ceiling lamp with 4 lights. Structure in bicolor methacrylate, white and transparent.

10

L 120 cm
P 20 cm
Attacco : GX 53-1.
Lampadine: 4 X 9 W max- GX 53-1 led
Screw: GX 53-1
Bulbs: 4 X 9 W max- GX 53-1 led



CL 584

Plafoniera rettangolare 2 luci in metacrilato bicolore bianco e trasparente.

Rectangular ceiling lamp with 2 lights. Structure in bicolor methacrylate, white and transparent.

10

L 60 cm
P 20 cm
Attacco : GX 53-1.
Lampadine: 2 X 9 W max- GX 53-1 led
Screw: GX 53-1
Bulbs: 2 X 9 W max- GX 53-1 led



CL 696

Plafoniera quadrata 6 luci in metacrilato bicolore bianco e trasparente.

Square ceiling lamp with 6 lights. Structure in bicolor methacrylate, white and transparent.

10

L 58 cm
P 58 cm
Attacco : GX 53-1.
Lampadine: 6 X 9 W max- GX 53-1 led
Screw: GX 53-1
Bulbs: 6 X 9 W max- GX 53-1 led



CL 582

Plafoniera quadrata 4 luci in metacrilato bicolore bianco e trasparente.

Square ceiling lamp with 4 lights. Structure in bicolor methacrylate, white and transparent.

10

L 40 cm
P 40 cm
Attacco : GX 53-1.
Lampadine: 4 X 9 W max- GX 53-1 led
Screw: GX 53-1
Bulbs: 4 X 9 W max- GX 53-1 led



CL 699

Plafoniera quadrata 5 luci in metacrilato bicolore bianco e trasparente.

Square ceiling lamp with 5 lights. Structure in bicolor methacrylate, white and transparent.

10

L 48 cm
P 48 cm
Attacco : GX 53-1.
Lampadine: 5 X 9 W max- GX 53-1 led
Screw: GX 53-1
Bulbs: 5 X 9 W max- GX 53-1 led



CL 583

Plafoniera quadrata 1 luce in metacrilato bicolore bianco e trasparente.

Square ceiling lamp. Structure in bicolor methacrylate, white and transparent.

10

L 20 cm
P 20 cm
Attacco : GX 53-1.
Lampadine: 1 X 9 W max- GX 53-1 led
Screw: GX 53-1
Bulbs: 1 X 9 W max- GX 53-1 led



CL 576

Spot in metacrilato bicolore bianco e trasparente.
Spot. Structure in bicolor methacrylate, white and transparent.

10

Ø 18 cm
Attacco : GX 53-1.
Lampadine: 1 X 9 W max- GX 53-1 led
Screw: GX 53-1
Bulbs: 1 X 9 W max- GX 53-1 led



INCASSO

design by UTE

CL 1580

Faretto in alluminio cromo opaco, placca rotonda in acrilico disponibile nei colori : oro, bronzo, cromo, satinato, bianco e rosso.

Spotlight in matt chrome Aluminium. Round plaque in acrylic available in the following colours: gold, bronze, chrome, opaline white, white, red.



Ø 10 cm



Attacco GU 10

GU 10 screw



CL 1581

Faretto in alluminio cromo opaco, placca quadrata in acrilico disponibile nei colori : oro, bronzo, cromo, satinato, bianco e rosso.

Spotlight in matt chrome Aluminium. Square plaque in acrylic available in the following colours: gold, bronze, chrome, opaline white, white, red.



L 10 cm



Attacco GU 10

GU 10 screw



CL 1582

Faretto in alluminio cromo opaco, placca rettangolare in acrilico disponibile nei colori : oro, bronzo, cromo, satinato, bianco e rosso.

Spotlight in matt chrome Aluminium. Rectangular plaque in acrylic available in the following colours: gold, bronze, chrome, opaline white, white, red.



L 18 cm



Attacco GU 10

GU 10 screw



oro



bronzo



cromo



satinato



bianco



rosso

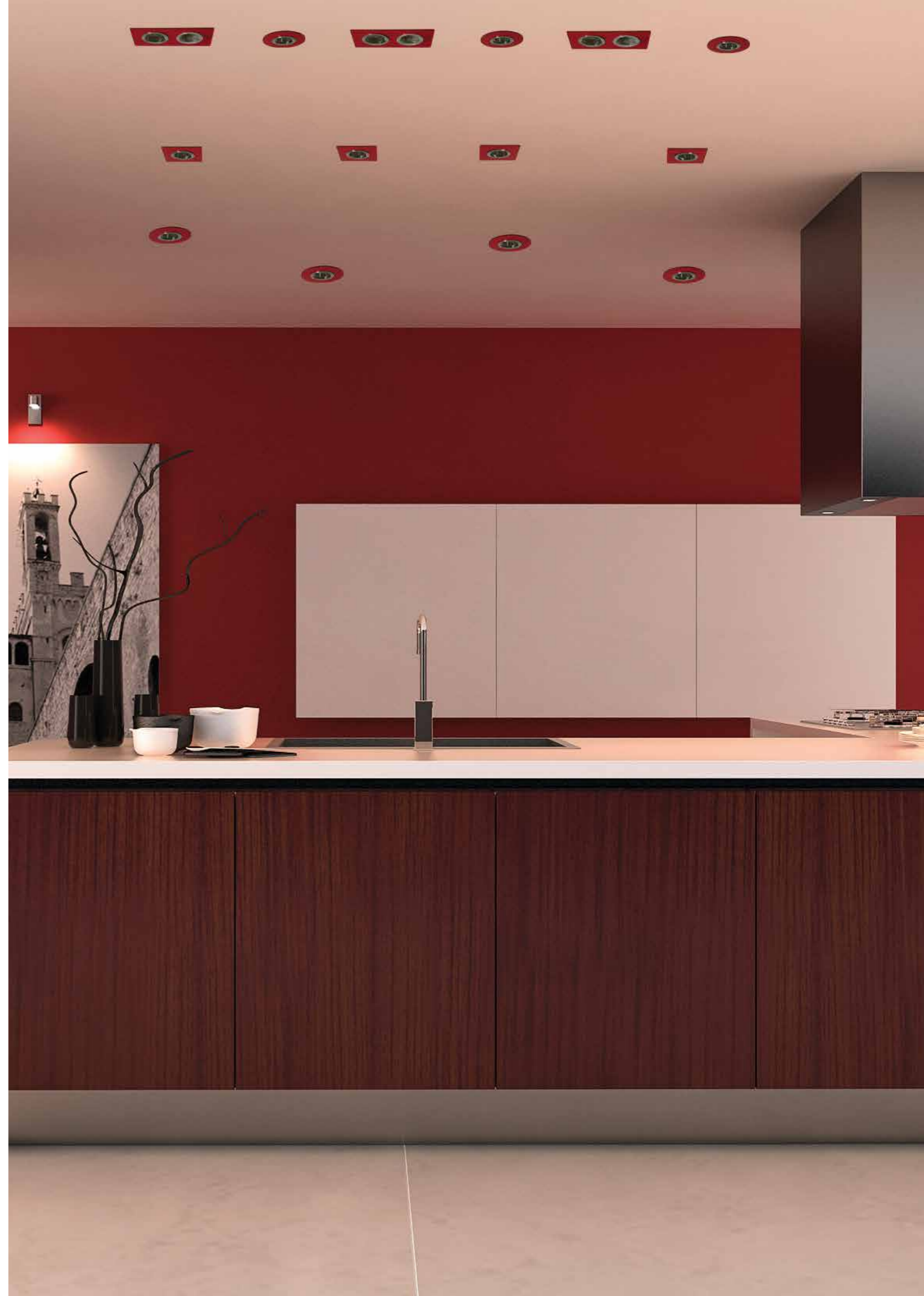

FORTUNA

design by **Walter Sbicca**

CL 1586

Plafone in PMMA opalino.

Ceiling lamp in opaline PMMA.

10

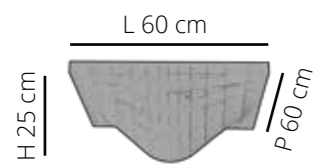

Attacco E27.
Lampadine: 1 x 70 W max - E27 HGS

E27 screw.
Bulbs: 1 x 70 W max - E27 HGS



RELOAD

design by UTE

CL 406

*Sospensione con paralume in materiale plastico termofuso di cui una parte derivante dal processo di riciclo.
Disponibile nei colori bianco o multicolor.*

*Suspension lamp partially made from recycled plastic.
Available in white or multicolour.*

10,99

Ø 48
H 52 cm
Attacco E27. Filo L. 160 cm.
Lampadine: 1 x 70 W max - E27 HGS
E27 screw. Wire length 160 cm.
Bulbs: 1 x 70 W max - E27 HGS



RELOAD

design by UTE

CL 408

Lampada da terra con paralume in materiale plastico termofuso di cui una parte derivante dal processo di riciclo. Disponibile nei colori bianco o multicolor.

Floor lamp partially made from recycled plastic. Available in white or multicolour.

10 99

Ø 48



H 52 cm

Attacco E27.
Lampadine: 1 x 70 W max - E27 HGS

E27 screw.
Bulbs: 1 x 70 W max - E27 HGS

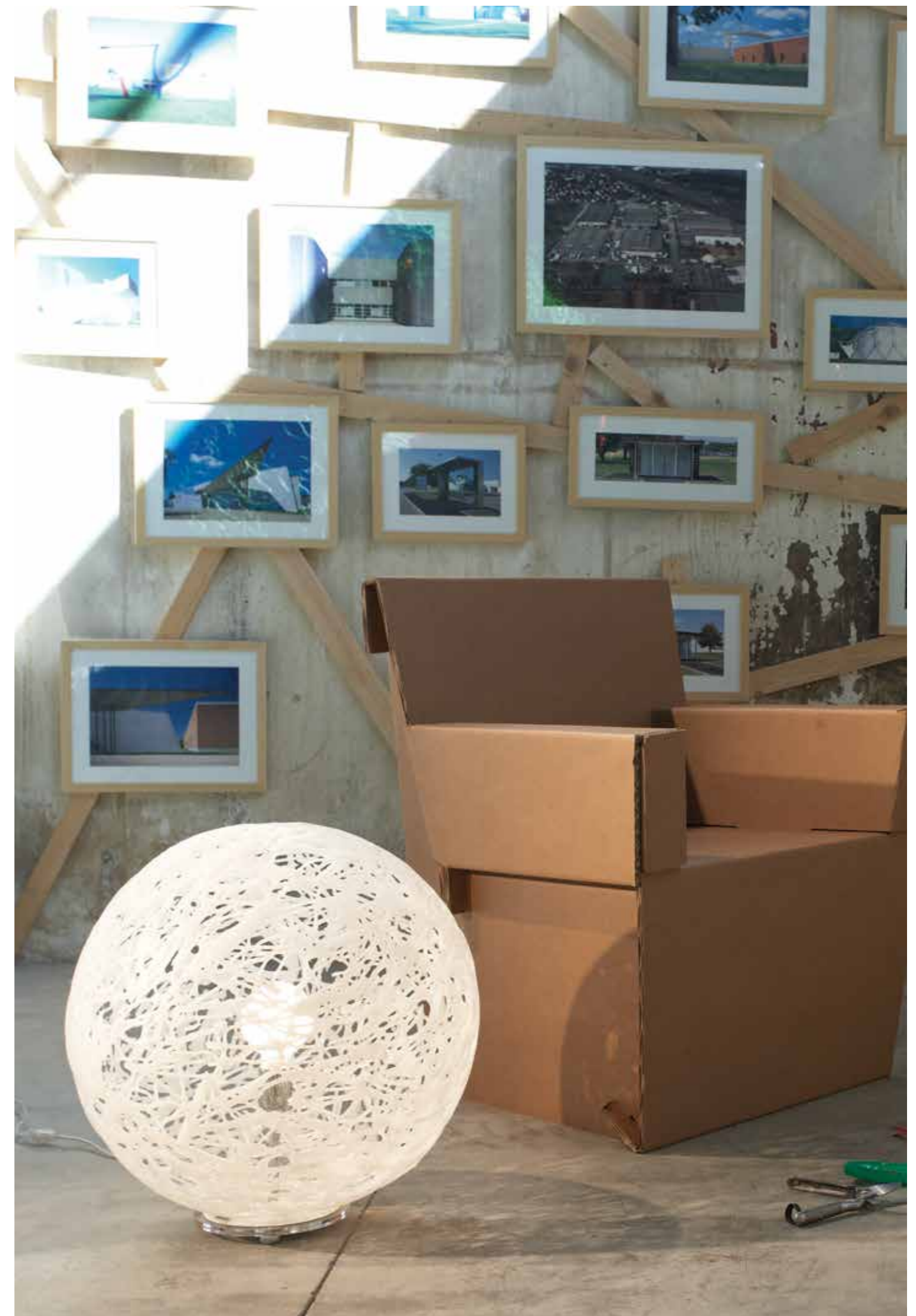

RELOAD

design by UTE

CL 407

Plafoniera con paralume in materiale plastico termofuso di cui una parte derivante dal processo di riciclo. Disponibile nei colori bianco o multicolor.

Ceiling lamp partially made from recycled plastic. Available in white or multicolour.

10 99

∅ 48 cm



H 52 cm

Attacco E27.
Lampadine: 1 x 70 W max - E27 HGS

E27 screw.
Bulbs: 1 x 70 W max - E27 HGS



RELOAD



GALLES SMALL

design by UTE



GALLES LARGE

design by UTE



GALLES SMALL

design by UTE

CL 1447

Sospensione in metacrilato sp. 20 mm.
Disponibile nei colori: trasparente, satinato e fumè.

Methacrylate suspension lamp thickness 20 mm.
Available in: transparent, opaline white and smoked grey.

11 12 91

Ø 90

Strip Led IP20 - 12V tot. 75W - Luce naturale 4000 K +5%, 15 IM/LED
Strip Led IP20 - 12V tot. 75W - light 4000 K+ 5%, 15 IM/ LED



GALLES LARGE

design by UTE

CL 1446

Sospensione a 6 luci in metacrilato sp. 20 mm.
Disponibile nei colori: trasparente, satinato e fumè.

6 light methacrylate suspension lamp thickness 20 mm.
Available in: transparent, opaline white and smoked grey.

11 12 91

Ø 127

Lampadine: 6x15W risparmio energetico. E27 FBT 6x11W LED
Bulbs: 6x15W energy saving. FBT E27 6x11W LED

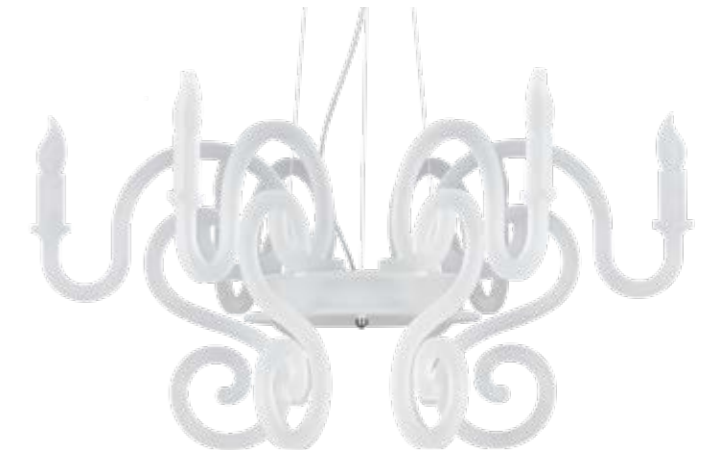

BONBONNE

design by Walter Sbicca

OUTDOOR



BONBONNE

design by **Walter Sbicca**

CL 1547

Lampada da terra per esterni in vetro stampato, paralume decorativo in policarbonato trasparente con texture colore marrone.

Disco di sostegno traforato in metacrilato fumè.

(paralume personalizzabile su richiesta)

Outdoor molded glass floor lamp, decorative shade in transparent polycarbonate with brown texture. Pierced support disk in smoked methacrylate.

(custom lampshade on request)



59

ø 59 cm



H 82 cm

IP 44 - Attacco E 27.
Lampadine 2 x 70 W max
E27 - HGS

IP 44 - E27 screw.
Bulbs: 2 x 70 w max
E27 - HGS

BONBONNE

design by **Walter Sbicca**

CL 1550

Lampada da terra per esterni in vetro stampato, paralume decorativo in policarbonato trasparente con texture colore marrone.

Disco di sostegno traforato in metacrilato fumè.

(paralume personalizzabile su richiesta)

Outdoor molded glass floor lamp, decorative shade in transparent polycarbonate with brown texture. Pierced support disk in smoked methacrylate.

(custom lampshade on request)



59

ø 59 cm



H 69 cm

IP 44 - Attacco E 27.
Lampadine 1 x 70 W max
E27 - HGS

IP 44 - E27 screw.
Bulbs: 1 x 70 w max
E27 - HGS



BONBONNE

design by Walter Sbicca



CL 1551

Lampada da terra per esterni in vetro stampato, paralume decorativo in sandylex natural con texture colore marrone.

Disco di sostegno traforato in metacrilato fumè. (paralume personalizzabile su richiesta)

Outdoor molded glass floor lamp, decorative shade in natural sandylex with brown texture.

Pierced support disk in smoked methacrylate. (custom lampshade on request)

59

ø 59 cm



H 69 cm

IP 44 - Attacco E 27.
Lampadine 1 x 70 W max
E27 - HGS

IP 44 - E27 screw.
Bulbs: 1 x 70 w max
E27 - HGS



CL 1548

Lampada da terra per esterni in vetro stampato, paralume decorativo in sandylex natural con texture colore marrone.

Disco di sostegno traforato in metacrilato fumè. (paralume personalizzabile su richiesta)

Outdoor molded glass floor lamp, decorative shade in natural sandylex with brown texture.

Pierced support disk in smoked methacrylate. (custom lampshade on request)

59

ø 59 cm



H 82 cm

IP 44 - Attacco E 27.
Lampadine 2 x 70 W max
E27 - HGS

ip 44 - E27 screw.
Bulbs: 2 x 70 w max
E27 - HGS



BONBONNE

design by **Walter Sbicca**

CL 1549

Lampada da terra per esterni in vetro stampato, paralume decorativo in sandylex natural. Disco di sostegno traforato in metacrilato fumè. (paralume personalizzabile su richiesta)

Outdoor molded glass floor lamp, decorative shade in natural sandylex. Pierced support disk in smoked methacrylate. (custom lampshade on request)

10

ø 59 cm



H 82 cm

IP 44 - Attacco E 27.
Lampadine 2 x 70 W max
E27 - HGS

IP 44 - E27 screw.
Bulbs: 2 x 70 w max
E27 - HGS



BONBONNE

design by **Walter Sbicca**

CL 1552

Lampada da terra per esterni in vetro stampato, paralume decorativo in sandylex natural. Disco di sostegno traforato in metacrilato fumè. (paralume personalizzabile su richiesta)

Outdoor molded glass floor lamp, decorative shade in natural sandylex. Pierced support disk in smoked methacrylate. (custom lampshade on request)

10

ø 59 cm



H 69 cm

IP 44 - Attacco E 27.
Lampadine 1 x 70 W max
E27 - HGS

IP 44 - E27 screw.
Bulbs: 1 x 70 w max
E27 - HGS



BONBONNE MINI

design by Walter Sbicca

CL 1599

Lampada da tavolo per esterno in vetro stampato, paralume in Sandylex natural disco traforato in metacrilato fumè.

Table lamp for outdoor in printed glass, lampshade in natural sandylex, perforated disc in smoked methacrylate.

10

ø 46 cm



H 68 cm

IP 44 Attacco E 27.
Lampadine 1/2 x 70 W max o 30 W led
E27 - HGS

E27 screw.
Bulbs: 1/2 x 70 W max or 30 W led
E27 - HGS



BONBONNE MINI

design by Walter Sbicca

CL 1598

Lampada da tavolo per esterno in vetro stampato, paralume in policarbonato trasparente disco traforato in metacrilato fumè.

Paralume disponibile nei colori: texture marrone, grigio pizzo nero.

Table lamp for outdoor in printed glass, lampshade in transparent polycarbonate, perforated disc in smoked methacrylate.

Lampshade available in the following colours: brown texture, grey, black lace.

59 91 05

ø 46 cm



H 68 cm

Attacco E 27.
Lampadine 1/2 x 70 W max o 30 W led
E27 - HGS

E27 screw.
Bulbs: 1/2 x 70 W max or 30 W led
E27 - HGS



QUATTROSTAGIONI

design by **Walter Sbicca**

CL 1555

Sospensione per esterno componenti: disco sostegno in metacrilato fumè, globo in metacrilato opalino, paralume in policarbonato trasparente.

Disponibile nelle versioni : texture colore grigio - marrone - folk bianco.

Outdoor suspension lamp. Components: support disk in smoked methacrylate, globe in opal methacrylate, lampshade in transparent polycarbonate.

Available in the following versions: texture gray - brown - folk white.

91 59 10

Ø 60



H 46 cm

IP 44 Attacco E27. Filo 160 cm.
Lampadine: 1 x 70 W Max - E 27 HGS o 15 W led

IP 44 E 27 Screw. Wire 160 cm.
Bulbs: 1 x 70 w max - and 27 HGS or 15 W led



QUATTROSTAGIONI

design by **Walter Sbicca**

CL 1556

Sospensione per esterno componenti: disco sostegno in metacrilato fumè, globo in metacrilato opalino, aralume in policarbonato trasparente.

Disponibile nelle versioni : texture colore grigio - marrone - folk bianco.

Outdoor suspension lamp. Components: support disk in smoked methacrylate, globe in opal methacrylate, lampshade in transparent polycarbonate.

Available in the following versions: texture gray - brown, folk white.

91 59 10

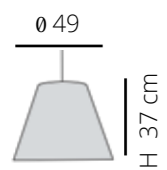

IP 44 Attacco E27. Filo 160 cm.
Lampadine: 1 x 70 W Max - E 27 HGS o 15 W led



IP 44 E 27 Screw. Wire 160 cm.
Bulbs: 1 x 70 w max - and 27 HGS or 15 W led



CL 1557

91 59 10

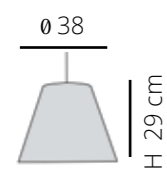

IP 44 Attacco E27. Filo 160 cm.
Lampadine: 1 x 70 W Max - E 27 HGS o 15 W led



IP 44 E 27 Screw. Wire 160 cm.
Bulbs: 1 x 70 w max - and 27 HGS or 15 W led



QUATTROSTAGIONI

design by Walter Sbicca

CL 1558

Sospensione per esterno componenti: disco sostegno in metacrilato fumè, globo in metacrilato opalino, paralume in sandylexnatural.

Outdoor suspension lamp. Components: support disk in smoked methacrylate, opal methacrylate globe in natural, sandylex lampshade.

10

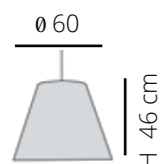

IP 44 Attacco E27. Filo 160 cm.
Lampadine: 1 x 70 W Max - E 27 HGS o 15 W led

IP 44 E 27 Screw. Wire 160 cm.
Bulbs: 1 x 70 w max - and 27 HGS or 15 W led



CL 1559

10

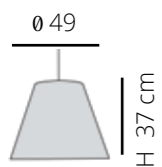

IP 44 Attacco E27. Filo 160 cm.
Lampadine: 1 x 70 W Max - E 27 HGS o 15 W led

IP 44 E 27 Screw. Wire 160 cm.
Bulbs: 1 x 70 w max - and 27 HGS or 15 W led



CL 1560

10

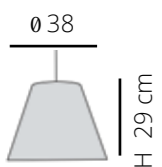

IP 44 Attacco E27. Filo 160 cm.
Lampadine: 1 x 70 W Max - E 27 HGS o 15 W led

IP 44 E 27 Screw. Wire 160 cm.
Bulbs: 1 x 70 w max - and 27 HGS or 15 W led



ANGIPU'

design by **Walter Sbicca**

CL 1554

Lampada da terra per esterni in metacrilato trasparente, paralume decorativo in policarbonato trasparente disponibile nelle versioni : texture colore grigio - texture folk bianco. Disco di sostegno in metacrilato trasparente, base in polipropilene bianco. (paralume personalizzabile su richiesta)

Outdoor floor lamp in transparent methacrylate, decorative shade in transparent polycarbonate available in the following versions: texture gray color - white folk texture. Disk in transparent methacrylate, base in white polypropylene. (custom lampshade on request)

91 10

Ø 59



H 88 cm

IP 44 Attacco E27.
Lampadine: 1 x 70 W Max - E 27 HGS o 15 W led

IP 44 E 27 Screw.
Bulbs: 1 x 70 w max - and 27 HGS or 15 W led

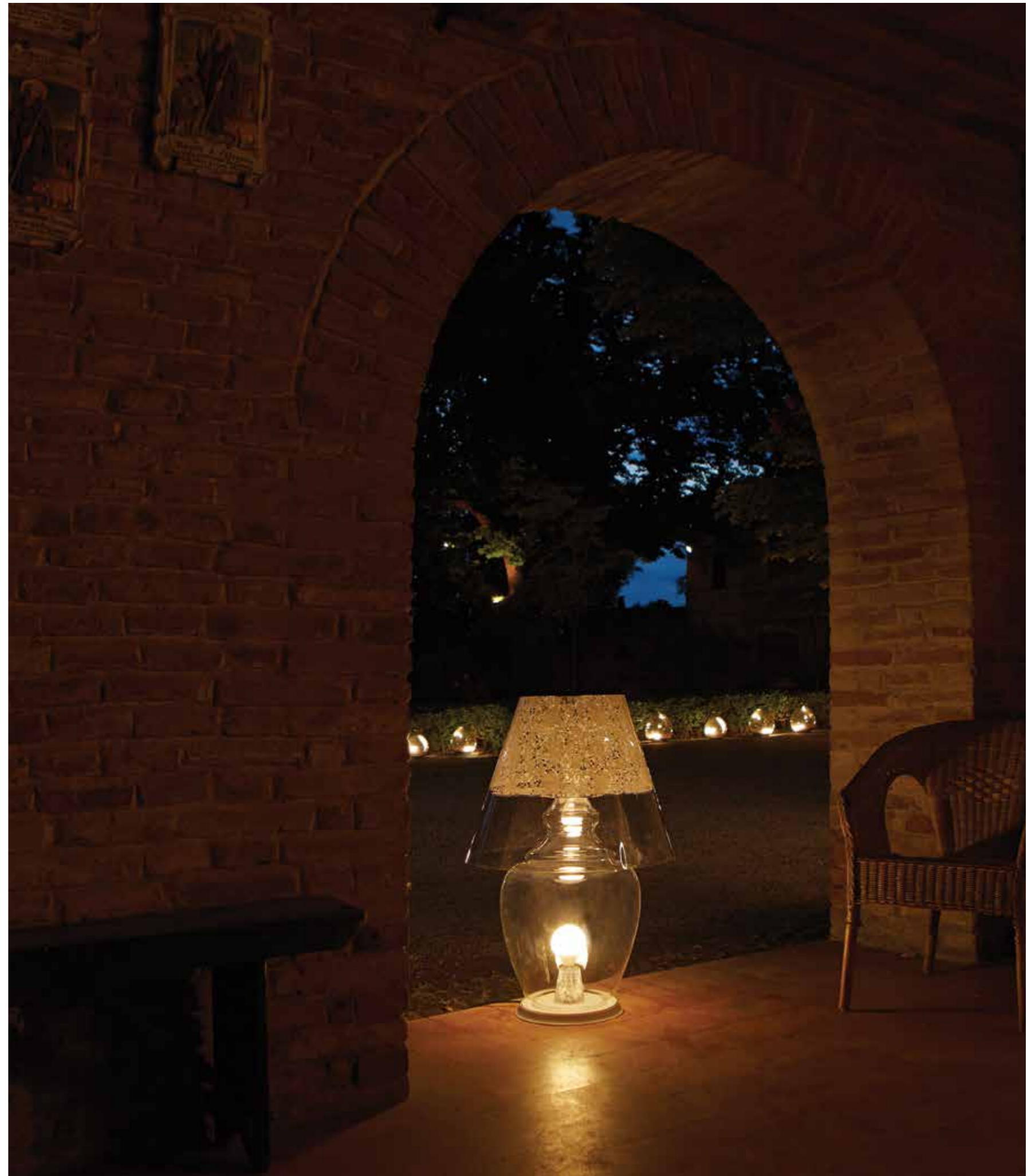

ANGIPU'

design by **Walter Sbicca**

CL 1553

Lampada da terra per esterni in metacrilato opalino, paralume decorativo in policarbonato trasparente disponibile nelle versioni: texture colore grigio - texture folk bianco. Disco di sostegno in metacrilato trasparente, base in polipropilene bianco. (paralume personalizzabile su richiesta)

Outdoor floor lamp in opal methacrylate, decorative shade in transparent polycarbonate available in the following versions: texture gray color - white folk texture. Disk in transparent methacrylate, base in white polypropylene. (custom lampshade on request)

91 10

Ø 59



H 88 cm

IP 44 Attacco E27.
Lampadine: 1 x 70 W Max - E 27 HGS o 15 W led

IP 44 E 27 Screw.
Bulbs: 1 x 70 w max - and 27 HGS or 15 W led



RELOAD

design by UTE

CL 443

Lampada da terra per esterni con paralume in materiale plastico termofuso di cui una parte derivante dal processo di riciclo. Disponibile nei colori bianco o multicolor.

Outdoor floor lamp . Lampshade partially made from recycled plastic. Available in white or multicolour.

10 99

Ø 48



H 52 cm

IP 44 Attacco E27.
Lampadine: 1 x 70 W max
E27 - HGS

IP 44 E27 screw.
Bulbs: 1 x 70 W max
E27 - HGS



EMPORIUM

teen light

CYLINDER

design by Lucia Pierini



FIORI



BOTTONI



RIGHE



CUORI



GIUNGLA

CL 1525 - Ø 30 H 19,6 cm

Sospensione, paralume in Sandylex con texture.
Particolari in metacrilato.

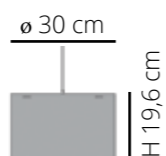

Suspension lamp. Lampshade in Sandylex with texture.
Methacrylate details.

Attacco E 27. Filo L. 160cm
Lampadine 1 x 70 W max - E27 HGS

E27 screw. Wire length 160 cm.
Bulbs: 1 x 70 w max - E27 HGS



CL 1526 - Ø 45 H 29 cm

Sospensione, paralume in Sandylex con texture.
Particolari in metacrilato.

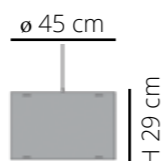

Suspension lamp. Lampshade in Sandylex with texture.
Methacrylate details.

Attacco E 27. Filo L. 160cm
Lampadine 1 x 70 W max - E27 HGS

E27 screw. Wire length 160 cm.
Bulbs: 1/2 x 70 w max - E27 HGS



CYLINDER ABAT-JOUR

design by Lucia Pierini

CL 1527 - Ø 18 H 25 cm

*Abat-Jour, Paralume in sandilex con texture, particolari in metacrilato.
Base in forex bianco, accessori in metallo verniciato.*

*Bedside lamp. Lampshade in Sandylex with texture, methacrylate details.
Base in white forex, metal coated fittings.*



FIORI



BOTTONI



RIGHE



CUORI



GIUNGLA

Ø 18 cm



H 25 cm

Attacco E 14.
Lampadine 1 x 28 W max - E14 FBT

E14 screw.
Bulbs: 1 x 28 w max - E14 HGS FBT



KONE

design by Lucia Pierini



BOLLI



STRISCE



MONGOLFIERE



ORSETTO



STELLE

CL 1522 - Ø 30 H 27 cm

Sospensione, paralume in Sandylex con texture.
Particolari in metacrilato.

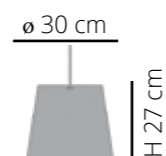

Attacco E 27. Filo L. 160cm
Lampadine 1 x 70 W max - E27 HGS

E27 screw. Wire length 160 cm.
Bulbs: 1 x 70 w max - E27 HGS



Suspension lamp. Lampshade in Sandylex with texture.
Methacrylate details.

CL 1523 - Ø 42 H 36 cm

Sospensione, paralume in Sandylex con texture.
Particolari in metacrilato.

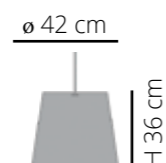

Attacco E 27. Filo L. 160cm
Lampadine 2 x 70 W max - E27 HGS

E27 screw. Wire length 160 cm.
Bulbs: 1/2 x 70 w max - E27 HGS



Suspension lamp. Lampshade in Sandylex with texture.
Methacrylate details.



KONE ABAT-JOUR

design by Lucia Pierini

CL 1524 - Ø 18 H 25 cm

*Abat-Jour, Paralume in sandilex con texture, particolari in metacrilato.
Base in forex bianco, accessori in metallo verniciato.*

*Bedside lamp. Lampshade in Sandylex with texture, methacrylate details.
Base in white forex, metal coated fittings.*



BOLLI



STRISCE



MONGOLFIERE



ORSETTO



STELLE

Ø 18 cm



H 25 cm

Attacco E 14.
Lampadine 1 x 28 W max - E14 FBT

E14 screw.
Bulbs: 1 x 28 w max - E14 HGS FBT



DOULI

design by UTE

CL 1529 - Ø 40 H 42 cm

*Sospensione, paralume in Sandylex con texture.
Disponibile nelle versioni : onde, car, emotion,
arlecchino e anelli.*

*Suspension lamp. Lampshade in Sandylex with texture.
Available in : waves, cars, emotions, multicolor and rings.*

Ø 40 cm



H 42 cm

Attacco E 27. Filo L. 160cm
Lampadine 1 x 70 W max - E27 HGS

E27 screw. Wire length 160 cm.
Bulbs: 1 x 70 w max - E27 HGS



STAR

design by Lucia Pierini

CL 1532 - L 56 P 56 H 27 cm

Sospensione in cristallo acrilico trasparente con texture
Disponibile nei colori : multicolor e fucsia.
Particolari in metallo cromato.

Suspension lamp in transparent crystal acrylic with texture.
Available in : multicolor and fuchsia.
Chromed metal details.



Attacco E 27. Filo L. 160 cm
Lampadine 1 x 70 W max - E27 HGS

E27 screw. Wire lenght 160 cm.
Bulbs: 1 x 70 w max - E27 HGS



99 49



CL 1533 - L 56 P 56 H 13 cm

Plafoniera in cristallo acrilico trasparente con texture. Dispo-
nibile nei colori : multicolor e fucsia.
Particolari in metallo cromato e verniciato.

Ceiling lamp in transparent crystal acrylic with texture.
Available in : multicolor and fuchsia.
Chromed metal details.



Attacco E 27.
Lampadine 1 x 70 W max - E27 HGS

E27 screw.
Bulbs: 1 x 70 w max - E27 HGS

99 49

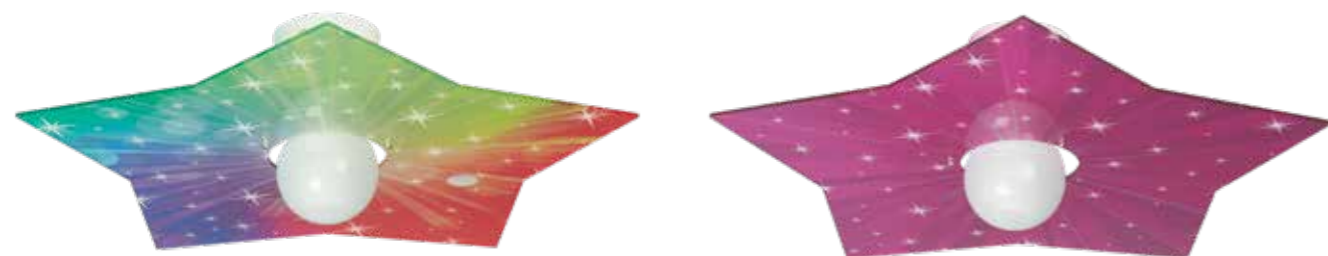

SOL

design by Lucia Pierini

CL 1530 - Ø 50 H 13 cm

Sospensione in cristallo acrilico trasparente con texture.
Disponibile nei colori : giallo e rosso.
Particolari in metallo cromato.

Suspension lamp in transparent crystal acrylic with texture.
Available in : yellow and red.
Chromed metal details.

Ø 50 cm



H 13 cm

Attacco E 27. Filo L. 160 cm
Lampadine 1 x 70 W max - E27 HGS

E27 screw. Wire lenght 160 cm.
Bulbs: 1 x 70 w max - E27 HGS



21 51

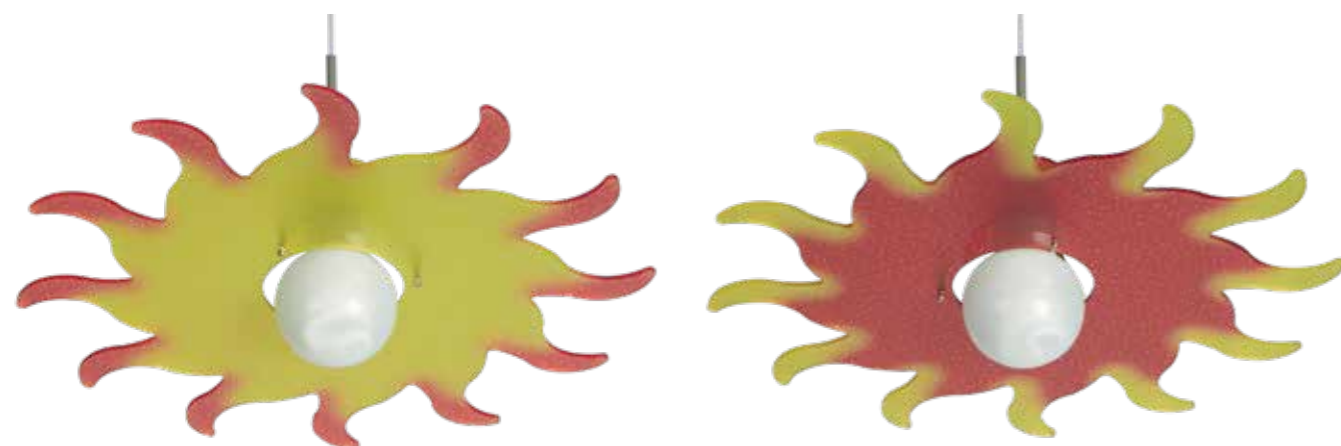

CL 1531 - Ø 50 H 13 cm

Plafoniera in cristallo acrilico trasparente con texture. Dispo-
nibile nei colori : giallo e rosso.
Particolari in metallo cromato e verniciato.

Ceiling lamp in transparent crystal acrylic with texture.
Available in : yellow and red.
Chromed metal details.

Ø 50 cm



H 13 cm

Attacco E 27.
Lampadine 1 x 70 W max - E27 HGS

E27 screw.
Bulbs: 1 x 70 w max - E27 HGS

21 51



CLOUD

design by Lucia Pierini

CL 1534 - L 50 P 40 H 13 cm

Sospensione in cristallo acrilico trasparente con texture.
Disponibile nei colori : blu e fuxia.
Particolari in metallo cromato.

Suspension lamp in transparent crystal acrylic with texture.
Available in : blue and fuchsia. Chromed metal details.

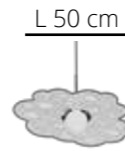

P 40 cm

Attacco E 27. Filo L. 160 cm
Lampadine 1 x 70 W max - E27 HGS

E27 screw. Wire lenght 160 cm.
Bulbs: 1 x 70 w max - E27 HGS



61 49

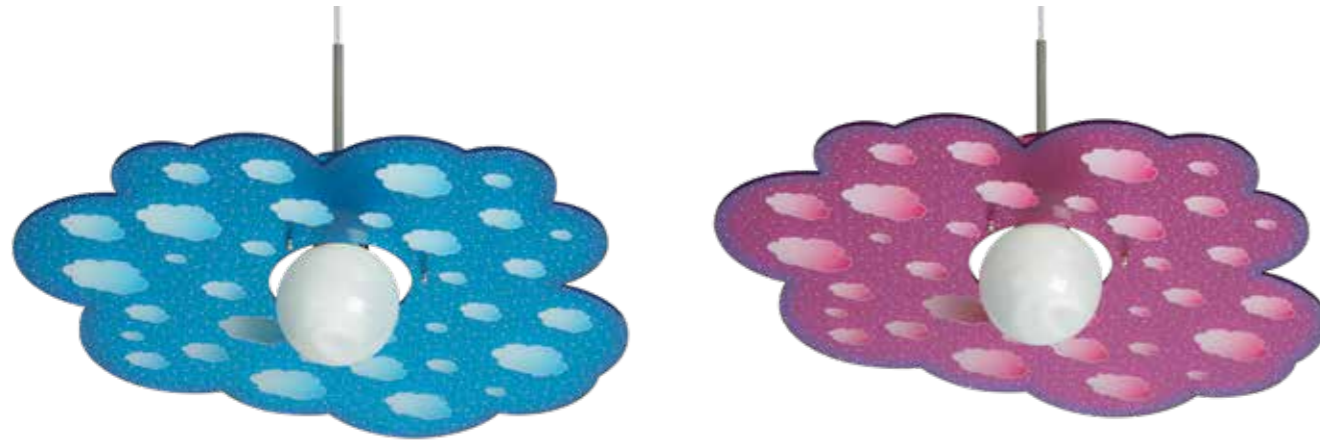

CL 1535 - L 50 P 40 H 13 cm

Plafoniera in cristallo acrilico trasparente con texture. Disponibile nei colori : blu e fuxia.
Particolari in metallo cromato e verniciato.

Ceiling lamp in transparent crystal acrylic with texture.
Available in : blue and fuchsia.
Chromed metal details.

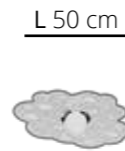

P 40 cm

Attacco E 27.
Lampadine 1 x 70 W max - E27 HGS

E27 screw.
Bulbs: 1 x 70 w max - E27 HGS

61 49



BUTTERFLY

design by Lucia Pierini

CL 1528 - Ø 55 H 32 cm

Sospensione in metacrilato trasparente con texture multicolor.
Particolari in metallo verniciato.

Suspension lamp in transparent methacrylate with multicolour texture.
Metal coated details.

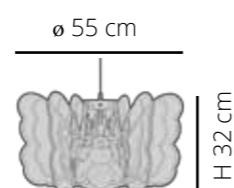

Attacco E 27. Filo L. 160cm
Lampadine 1 x 70 W max - E27 HGS

E27 screw. Wire lenght 160 cm.
Bulbs: 1 x 70 w max - E27 HGS



NEVEA

design by Melissa Giacchi

CL 1461 - L 16 P 24 H 28 cm

Lampada da tavolo in sandylex con texture. Supporto in metacrilato trasparente, contenitore in banda stagnata silver.

Table lamp in sandylex with texture, transparent methacrylate support and pen holder in silver color.



FIORI



BOLLI



RIGHE



FASCIE

P 24 cm



H 28 cm

Attacco E 14.
Lampadine 1 x 28 W max - E14 HGS

E14 screw.
Bulbs: 1 x 28 w max - E14 HGS

Colori_Colours

- 05 Nero/Black
- 10 Bianco/White
- 11 Trasparente/Transparent
- 12 Bianco satinato/Opaline white
- 14 Bianco matt/Matt white • Natural opal
- 15 Bianco perla/Pearl white
- 20 Verde/Green
- 21 Giallo/Yellow
- 29 Viola/Violet
- 32 Oro/Gold
- 33 Argento/Silver
- 34 Cromato/Chromed
- 35 Dorato/Golden
- 36 Rame/Copper
- 41 Arancio/Orange
- 48 Rosa/Pink
- 49 Fucsia/Fuchsia
- 51 Rosso/Red
- 53 Nuance Rosso/Nuance Red
- 55 Cromolite
- 57 Oro/Gold
- 58 TexturGold
- 59 Bronzo/Bronze
- 61 Blu/Blue
- 63 Celeste/Light blue
- 64 Celeste opal/Light blue opal
- 67 Tessuto intrecciato
- 70 Frassino/Ash wood
- 71 Noce/Walnut
- 88 Spectrall
- 89 Decoro fili/Thread-like decoation
- 91 Nuance grigio/Nuance gray
- 94 Grigio matt/Matt gray • Grigio opal/Gray opal
- 95 Bicolor bianco satinato/cromolite
Bicolor opaline white/cromolite
- 97 Bicolor bianco satinato/oro
Bicolor opaline white/gold
- 98 Fume'
- 99 Multicolor/Multicolour

DESIGNERS

UTE EMPORIUM
WALTER SBICCA
ROMEO GUARICCI
LETIZIA MAMMINI
VALERIA CANDIDO
MELISSA GIACCHI
NICOLA CERASA
ALBERTO VALLESI
ERMANNINO BAUDONE
MARTINA BONAN
GERARDO ENRICO CIARAMBINO
MATTEO CLERICO
ADA GAROMBO

AD WALTER SBICCA

PHOTO ANDREA BELLEZZA - GIULIA LOCCIONI

GRAPHIC DESIGN UFFICIO TECNICO EMPORIUM - GABRIELE PIERINI - ANDREA BELLEZZA

Tutti i prodotti sono **MADE IN ITALY**

*All products are **MADE IN ITALY***



EMPORIUM

Emporium srl - C/da Marolino - S.S. Regina Km 6,5 - 62018 Potenza Picena (MC) ITALY

Tel. (+39) 0733 671747 - Fax. (+39) 0733 870081

emporium@emporium.it - www.emporium.it







DESIGNERS



WALTER SBICCA



MAMMINI CANDIDO



LUCIA PIERINI



NICOLA CERASA

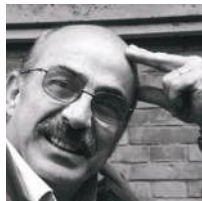

ROMEO GUARICCI



GAETANO AVITABILE



STUDIO KUBLA



LORENZO RADAELLI



ABOUT US

LO STRAORDINARIO QUOTIDIANO

Dal 1997 **Emporium** coniuga idee, materiali e stile per creare oggetti destinati alla vita di tutti i giorni. Con **Emporium** il design diventa pratico ed accessibile, il quotidiano si trasforma in una esperienza straordinaria, reinterpreta il concetto di luce e di spazio.

Nelle due collezioni "**The Special Light**" e "**Living Book**" il metacrilato, il policarbonato, il legno e le materie plastiche termofuse e riciclate prendono forma grazie a un mix di creatività ed esperienza. Illuminazione e complementi d'arredo vengono pensati per generare emozioni e suscitare un'inequivocabile sensazione di benessere.

POSITIVE DESIGN è il linguaggio di Emporium: una filosofia, un pensiero, uno stile di vita diverso e un modo nuovo di vivere il proprio ambiente. Nascono così creazioni in perfetto stile **Emporium** dal design leggero, essenziale ed ecosostenibile, per entrare nelle case di tutto il mondo.

Tutti i prodotti sono **MADE IN ITALY**.





ABOUT US

THE EXTRAORDINARY EVERYDAY

Emporium is a very fresh brand established in 1997 to promote a new culture of the extraordinary beautiful everyday through objects for lighting and living solutions all 100% designed and made in Italy. Since the early years **Emporium** has been combining ideas, materials and Italian style to create elegant suggestions to surround us day in, day out.

POSITIVE DESIGN is the language of Emporium: a philosophy, a thought, a different lifestyle. Design with Emporium becomes practical and accessible; the everyday becomes an extraordinary experience, reinterpreting the concept of light and space. In the two collections "**The Special Light**" and "**Living Book**" methacrylate, polycarbonate, wood and recycled plastics take shape thanks to a mix of creativity and experience.

Lighting and complementary furnishings are conceived to evoke emotions and offer up an unequivocal feeling of well-being.

This is how products are created in the perfect **Emporium** style, giving them a very light, essential and sustainable design for our worldwide clientele.

All products are **MADE IN ITALY**.



INDICE / INDEX

<i>Lampade - Lamps</i>	<i>pag. 8</i>
<i>Cora, Zoe, Satori - Cora, Zoe, Satori</i>	<i>pag. 14</i>
<i>Librerie - Bookcases</i>	<i>pag. 16</i>
<i>Amplificatore - Sound Amplifier</i>	<i>pag. 32</i>
<i>Tavoli, comodini, Mobiletti - Tables, Bedside tables, Units</i>	<i>pag. 34</i>
<i>Console - Console</i>	<i>pag. 75</i>
<i>Sgabelli - Stools</i>	<i>pag. 82</i>
<i>Carrelli, Portabottiglie - Trollies, Wine rack</i>	<i>pag. 90</i>
<i>Centrotavola - Table adornments</i>	<i>pag. 100</i>
<i>Vassoi - Trays</i>	<i>pag. 102</i>
<i>Servomuto - Valet stand</i>	<i>pag. 106</i>
<i>Appendiabiti - Clothes hanger</i>	<i>pag. 109</i>
<i>Fioriera - Flower box</i>	<i>pag. 114</i>
<i>Separè - Privacy screen</i>	<i>pag. 118</i>
<i>Scarpiera - Shoe racks</i>	<i>pag. 120</i>
<i>Cassettiere - Multipurpose units, Drawer unit,</i>	<i>pag. 127</i>
<i>Contenitore multiuso - Multi purposes container</i>	<i>pag. 130</i>
<i>Contenitore raccolta differenziata - Waste collection container</i>	<i>pag. 132</i>
<i>Portabiancheria, Cestini - Laundry basket, Wastepaper basket</i>	<i>pag. 134</i>
<i>Specchio, Orologi - Mirror, Clocks</i>	<i>pag. 140</i>
<i>Lettini per cani e gatti - Beds for dogs and cats</i>	<i>pag. 144</i>
<i>Portariviste, Portaombrelli - Magazine racks, Umbrella stands</i>	<i>pag. 148</i>
<i>Mensole - Shelves</i>	<i>pag. 156</i>
<i>Appendini - Clothes hooks</i>	<i>pag. 164</i>
<i>Porta CD - CDs case</i>	<i>pag. 169</i>

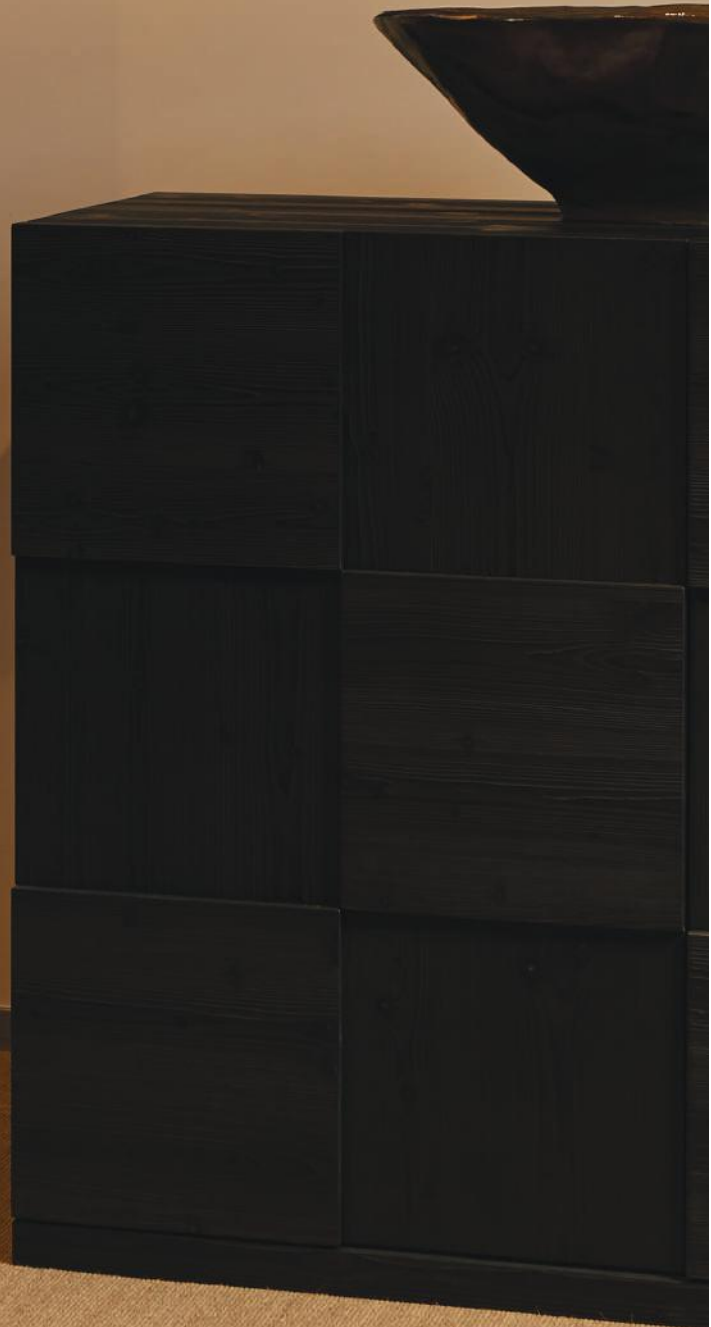
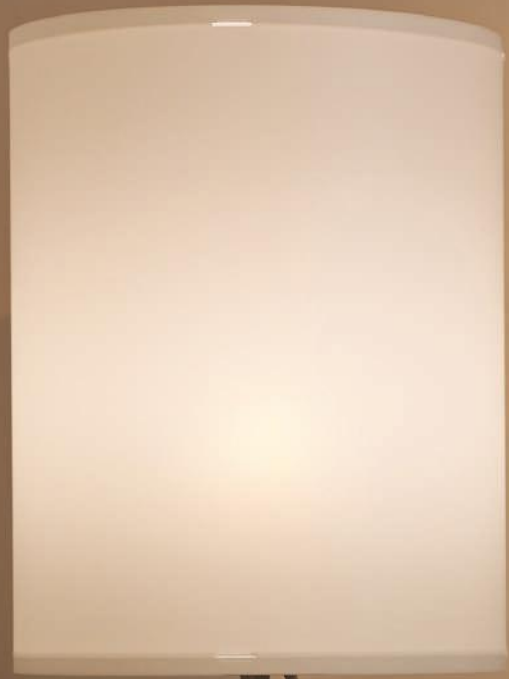

STONE

design by Nicola Cerasa

CL 1520



Lampada da terra con ripiani portaoggetti.
Struttura in metallo elaborato verniciato bianco.
Paralume in sandylex pearl particolari in PMMA satinato.
(Materiale Plastico Riciclabile)

*Floor lamp with shelves. White coated metal structure,
sandylex pearl lampshade, opaline white PMMA details.
(Recyclable Plastic Material)*

Ø 46 cm

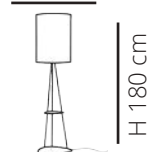

Attacco E 27
Lampadine 2 x 70 W max - E27 HGS

E27 screw
Bulbs: 2 x 70 w max - E27 HGS

15



CL 1521

Lampada da terra con ripiani portaoggetti.
Struttura in metallo elaborato verniciato bianco.
Paralume in sandylex con texture, decoro grigio,
particolari in PMMA satinato.
(Materiale Plastico Riciclabile)

*Floor lamp with shelves. White coated metal structure,
grey sandylex texture lampshade, opaline white PMMA details.
(Recyclable Plastic Material)*



Ø 46 cm

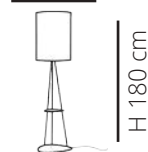

Attacco E 27
Lampadine 2 x 70 W max - E27 HGS

E27 screw
Bulbs: 2 x 70 w max - E27 HGS

91



LAMPADA DELL'AVVOCATO

design by **Walter Sbicca**

∅ 35 cm



H 40 cm

15

CL 1478

Lampada da tavolo: struttura in MDF laccato nero, paralume in Sandylex con stampa. (Materiale Plastico Riciclabile)

Table lamp. MDF structure coated black. Lampshade in printed Sandylex (Recyclable Plastic Material)



L 35 cm



H 40 cm

91 67 05

CL 1479

Lampada da tavolo: struttura in MDF laccato nero, paralume in Sandylex, rivestimento in tessuto con cerniera lampo, disponibile nei decori: feltro grigio, tessuto intrecciato e pizzo nero. (Materiale Plastico Riciclabile)

Table lamp. MDF structure coated black. Lampshade in braided Sandylex. Texture coating with zip available in grey felt material, branided net or black lace. (Recyclable Plastic Material)







VENTITREESIMO PREMIO COMPASSO D'ORO ADI
MILANO, VENTOTTO MAGGIO DUEMILAQUATTORDICI

Menzione d'Onore

Cora, Zoe

Designer

Roberto Giacomucci

Azienda

Emporium



Giurie

Anders Byriel, *Presidente* - Vivian Cheng - Stefan Diez - Giorgio De Ferrari - Mario Gagnon - Defne Koz - Paolo Lomazzi - Laura Traldi



CORA

design by UTE

CL 237 - L 68 P 69 H 77 cm

Poltrona in materiale plastico termofuso di cui una parte derivante dal processo di riciclo; è disponibile nella versione multicolour o bianca. (Materiale Plastico Riciclabile)

*Armchair partially made from recycled plastic.
Available colours: white or multicolor.
(Recyclable Plastic Material)*



ZOE

design by UTE

CL 236 - L 69 P 69 H 42 cm

Pouf in materiale plastico termofuso di cui una parte derivante dal processo di riciclo; è disponibile nella versione multicolour o bianca. (Materiale Plastico Riciclabile)

*Pouf partially made from recycled plastic.
Available colours: white or multicolor.
(Recyclable Plastic Material)*



SATORI

design by UTE

CL 238 - D 47 H 50 cm

*Pouf/stool. Partially made from recycled plastic.
Available colours white or multicolour.
(Recyclable Plastic Material)*

Pouf/sgabello in materiale plastico termofuso di cui una parte
derivante dal processo di riciclo; è disponibile nella versione
multicolour o bianca. (Materiale Plastico Riciclabile)



PLUS VERSION



Versione plus con aggiunta di polietilene; disponibile
nella versione multicolour o bianca.
(Materiale Plastico Riciclabile)

*Plus version with reinforced film.
Available colours: white or multicolour.
(Recyclable Plastic Material)*

CORA PLUS

CL 507 - L 68 P 69 H 77 cm

ZOE PLUS

CL 506 - L 69 P 69 H 42 cm

SATORI PLUS

CL 508 - D 47 H 50 cm





Storia dell'integrazione europea
Storia dell'integrazione europea

Storia dell'integrazione europea
Storia dell'integrazione europea

Storia dell'integrazione europea
Storia dell'integrazione europea

Storia dell'integrazione europea
Storia dell'integrazione europea

Storia dell'integrazione europea
Storia dell'integrazione europea

Storia dell'integrazione europea
Storia dell'integrazione europea

Storia dell'integrazione europea
Storia dell'integrazione europea

Storia dell'integrazione europea
Storia dell'integrazione europea

POCKET BIRDS

POCKET BIRDS

POCKET BIRDS

POCKET BIRDS

POCKET BIRDS

POCKET BIRDS

POCKET BIRDS

POCKET BIRDS

POCKET BIRDS

POCKET BIRDS

La Costituzione sul futuro dell'Europa
Una Costituzione per l'Europa

La Costituzione sul futuro dell'Europa
Una Costituzione per l'Europa

La Costituzione sul futuro dell'Europa
Una Costituzione per l'Europa

La Costituzione sul futuro dell'Europa
Una Costituzione per l'Europa

La Costituzione sul futuro dell'Europa
Una Costituzione per l'Europa

La Costituzione sul futuro dell'Europa
Una Costituzione per l'Europa

La Costituzione sul futuro dell'Europa
Una Costituzione per l'Europa

La Costituzione sul futuro dell'Europa
Una Costituzione per l'Europa

La Costituzione sul futuro dell'Europa
Una Costituzione per l'Europa

CL 2006 (6 ripiani / shelves) - L 35 P 35 H 100 cm

CL 2007 (10 ripiani / shelves) - L 35 P 35 H 154 cm

CL 2008 (14 ripiani / shelves) - L 35 P 35 H 200 cm

Libreria: corpo e ripiani in metacrilato trasparente spessore 6 mm.
Base e asta nella finitura metallo naturale, nero e bianco.
(Materiale Plastico Riciclabile)

Particolare // Detail



*Bookcase in transparent methacrylate, thickness 6 mm.
Base and structure in rough metal, black and white.
(Recyclable Plastic Material)*

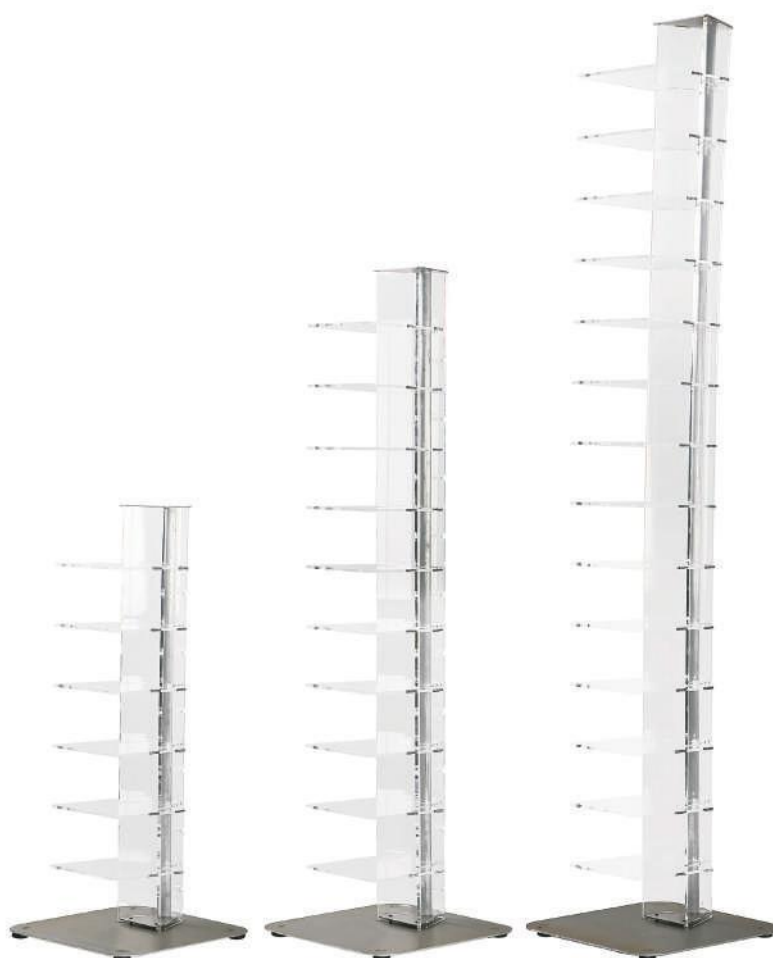







ELIB 7

design by Mammini Candido



CL 2020 - L 39 P 23 H 170 cm

Libreria da parete.
Struttura in metallo verniciato nero, ripiani in PMMA metacrilato, disponibile nei colori -trasparente - bianco - nero - satinato.
(Materiale Plastico Riciclabile)

*Bookcase with black coated metal structure, methacrylate PMMA shelves available in: transparent, white, black and opaline white. Wall mounting.
(Recyclable Plastic Material)*



ELIB 7

design by Mammini Candido

CL 2021 - L 39 P 23 H 170 cm

Libreria da parete.
Struttura in metallo verniciato bianco, ripiani in PMMA metacrilato, disponibile nei colori -trasparente - bianco - nero - satinato
(Materiale Plastico Riciclabile)

*Bookcase with white coated metal structure, methacrylate PMMA shelves available in: transparent, white, black and opaline white. Wall mounting.
(Recyclable Plastic Material)*





ELIB 3

design by Mammini Candido



CL 2018 - L 39 P 23 H 70 cm

Libreria da parete.

Struttura in metallo verniciato nero, ripiani in PMMA metacrilato, disponibile nei colori –trasparente - bianco - nero - satinato. (Materiale Plastico Riciclabile)

Bookcase with black coated metal structure, methacrylate PMMA shelves available in: transparent, white, black and opaline white. Wall mounting. (Recyclable Plastic Material)



ELIB 3

design by Mammini Candido

CL 2019 - L 39 P 23 H 70 cm

Libreria da parete.

Struttura in metallo verniciato bianco, ripiani in PMMA metacrilato, disponibile nei colori –trasparente - bianco - nero - satinato. (Materiale Plastico Riciclabile)

Bookcase with white coated metal structure, methacrylate PMMA shelves available in: transparent, white, black and opaline white. Wall mounting. (Recyclable Plastic Material)





URANIA

design by Romeo Guaricci

CL 2009 (da terra / ground version) - L 45 P 19 H 125 cm

Libreria: struttura in metacrilato spessore 10 mm nei colori trasparente, fumé e satinato. Fissaggio a muro. (Materiale Plastico Riciclabile)

Methacrylate bookcase, thickness 10 mm, available in transparent, opaline white and grey. Wall mounting. (Recyclable Plastic Material)



CLIO

design by Romeo Guaricci

CL 2010 (da parete / hanging version) - L 45 P 19 H 73 cm

Libreria: struttura in metacrilato spessore 10 mm nei colori trasparente, fumé e satinato. (Materiale Plastico Riciclabile)

Methacrylate bookcase, thickness 10 mm, available in transparent, opaline white and grey. Hanging version. (Recyclable Plastic Material)





MACRAMÈ

design by UTE

CL 012 - L 100 P 12 H 100 cm

Elemento da parete modulare per libri, CD, DVD ecc.
in metacrilato, disponibile nei colori nero, trasparente,
rosso e satinato. (Materiale Plastico Riciclabile)

*Wall system for books, CDs, DVDs, etc.
Available in black, transparent, red and opaline white.
(Recyclable Plastic Material)*





Sociologia del Lavoro
La Sociologia Economica Europea
Una rassegna triennale italiana
La Sociologia Economica Europea
Un confronto Euro-Mediterraneo
Con il numero dell'anno di
fondazione della rivista
FrancoAngeli

Sociologia del Lavoro
IMMIGRAZIONE
E LAVORO
A cura di Roberto Sabatini e Tullio Sassi
FrancoAngeli

Giovani, lavoro e società:
valori e orientamenti tra
continuità e discontinuità
A cura di
FrancoAngeli

Nel economy e
microimprenditorialità:
ricerca, sviluppo e prospettive
FrancoAngeli

Sociologia del Lavoro
IL LAVORO COME
CAMBIA,
COME SI RAPPRESENTA
FrancoAngeli

BABELE

design by UTE

CL 997 - L 45 P 45 H 133 cm

Contenitore multiuso con base girevole per libri, riviste, CD e DVD. Realizzato in metacrilato nei colori trasparente e satinato. (Materiale Plastico Riciclabile)

Methacrylate multipurpose rotating rack for books, CDs or DVDs available in transparent or opaline white. (Recyclable Plastic Material)





ZIGZAG

design by Studio Kubla

CL 2054 - L 152 P 35 H 90 cm

Libreria da terra. Struttura in metallo laccato colore bianco. Sostegni in metacrilato disponibili nei colori : trasparente - satinato - nero - rosso. (Materiale Plastico Riciclabile)

Standing bookcase, white lacquered structure, methacrylate supports available in : transparent - opaline white - black - red. (Recyclable Plastic Material)



ZIGZAG

design by Studio Kubla

CL 2053 - L 152 P 35 H 90 cm

Libreria da terra. Struttura in metallo laccato colore grigio scuro. Sostegni in metacrilato disponibili nei colori : trasparente - satinato - nero - rosso. (Materiale Plastico Riciclabile)

Standing bookcase, dark grey lacquered structure, methacrylate supports available in : transparent - opaline white - black - red. (Recyclable Plastic Material)





TUBE

design by Nicola Cerasa

CL 2064 - L 27 P 20,5 H 20,5 cm

Amplifica suono per cellulari in marmo con supporto in metacrilato trasparente e particolari in ottone cromato.
Disponibile nei colori : bianco - nero - oro - rame.
(Materiale Plastico Riciclabile)

*Sound amplifier for mobile phones in marble with transparent methacrylate and chromed brass details.
Available in colours : white - black - gold - copper.
(Recyclable Plastic Material)*







VASSA

design by Gaetano Avitabile

CL 2051 - D 60 H 148 cm

Tavolino con lampada. Struttura in acciaio verniciato nero.
Gambe in legno di frassino naturale, ripiano in metacrilato
nero, paralume in sandylex pearl, cablaggio cavo rosso.
(Materiale Plastico Riciclabile)

*Table with lamp. Black lacquered steel structure.
Stems in natural ash wood. Black methacrylate shelf.
Pearl sandylex lampshade, red cable wiring.
(Recyclable Plastic Material)*

D 60 cm



H 148 cm

Attacco E 27
Lampadine 1 x 70 W max
E27 HGS

E27 screw
Bulbs: 1 x 70 w max
E27 HGS

05





CHIARA

design by **Walter Sbicca**

CL 2013 - L 53 P 45 H 122 cm

Tavolino con lampada: struttura in metallo verniciato disponibile nel colore nero e bianco.
Paralume in sandylex pearl, cablaggio rivestito in tessuto rosso.
(Materiale Plastico Riciclabile)

*Small table with lamp: metal structure available in black and white,
sandylex pearl lampshade and wiring covered with red fabric.
(Recyclable Plastic Material)*

L 53 cm



Attacco E 27
Lampadine 1 x 70 W max - E27 HGS

E27 screw
Bulbs: 1 x 70 w max - E27 HGS

05 **10**





ALVIN

design by UTE



CL 2026 - L 41 P 41 H 59 cm

Tavolino alto. Struttura in metacrilato nero, particolari in acciaio cromato, ripiani in legno nobilitato disponibile nei colori: grigio pietra - grigio cera - bianco premium - acero mondial (Materiale Plastico Riciclabile)

Tall table. Black methacrylate structure, metal chromed details, wood shelves available in colours: stone grey - wax grey - premium white - maple mondial (Recyclable Plastic Material)



CL 2027 - L 41 P 41 H 49 cm

Tavolino medio. Struttura in metacrilato nero, particolari in acciaio cromato, ripiani in legno nobilitato disponibile nei colori: grigio pietra - grigio cera - bianco premium - acero mondial. (Materiale Plastico Riciclabile)

Medium table. Black methacrylate structure, metal chromed details, wood shelves available in colours: stone grey - wax grey - premium white - maple mondial. (Recyclable Plastic Material)



CL 2028 - L 41 P 41 H 39 cm

Tavolino basso. Struttura in metacrilato nero, particolari in acciaio cromato, ripiani in legno nobilitato disponibile nei colori: grigio pietra - grigio cera - bianco premium - acero mondial. (Materiale Plastico Riciclabile)

Small table. Black methacrylate structure, metal chromed details, wood shelves available in colours: stone grey - wax grey - premium white - maple mondial. (Recyclable Plastic Material)





ALVIN

design by UTE



CL 2023 - L 41 P 41 H 59 cm

Tavolino alto. Struttura in metacrilato trasparente, particolari in acciaio cromato, ripiani in legno nobilitato disponibile nei colori: grigio pietra – grigio cera – bianco premium - acero mondial (Materiale Plastico Riciclabile)

Tall table. Transparent methacrylate structure, metal chromed details, wood shelves available in colours: stone grey – wax grey – premium white - maple mondial (Recyclable Plastic Material)



CL 2024 - L 41 P 41 H 49 cm

Tavolino medio. Struttura in metacrilato trasparente, particolari in acciaio cromato, ripiani in legno nobilitato disponibile nei colori: grigio pietra – grigio cera – bianco premium - acero mondial (Materiale Plastico Riciclabile)

Medium table. Transparent methacrylate structure, metal chromed details, wood shelves available in colours: stone grey – wax grey – premium white - maple mondial (Recyclable Plastic Material)



CL 2025 - L 41 P 41 H 39 cm

Tavolino basso. Struttura in metacrilato trasparente, particolari in acciaio cromato, ripiani in legno nobilitato disponibile nei colori: grigio pietra – grigio cera – bianco premium - acero mondial (Materiale Plastico Riciclabile)

Small table. Transparent methacrylate structure, metal chromed details, wood shelves available in colours: stone grey – wax grey – premium white - maple mondial (Recyclable Plastic Material)





ALVIN

design by UTE



CL 2029 - L 41 P 41 H 59 cm

Tavolino alto. Struttura in metacrilato satinato, particolari in acciaio cromato, ripiani in legno nobilitato disponibile nei colori: grigio pietra – grigio cera – bianco premium - acero mondial (Materiale Plastico Riciclabile)

Tall table. Opaline white methacrylate structure, metal chromed details, wood shelves available in colours: stone grey – wax grey – premium white - maple mondial (Recyclable Plastic Material)



CL 2030 - L 41 P 41 H 49 cm

Tavolino medio. Struttura in metacrilato satinato, particolari in acciaio cromato, ripiani in legno nobilitato disponibile nei colori: grigio pietra – grigio cera – bianco premium - acero mondial (Materiale Plastico Riciclabile)

Medium table. Opaline white methacrylate structure, metal chromed details, wood shelves available in colours: stone grey – wax grey – premium white - maple mondial (Recyclable Plastic Material)



CL 2031 - L 41 P 41 H 39 cm

Tavolino basso. Struttura in metacrilato satinato, particolari in acciaio cromato, ripiani in legno nobilitato disponibile nei colori: grigio pietra – grigio cera – bianco premium - acero mondial (Materiale Plastico Riciclabile)

Small table. Opaline white methacrylate structure, metal chromed details, wood shelves available in colours: stone grey – wax grey – premium white - maple mondial (Recyclable Plastic Material)





ATLANTE

design by Romeo Guaricci

CL 2000 - L 77 P 60 H 33 cm

Tavolino in metacrilato nelle versioni: base nera ripiano trasparente - base satinata e ripiano trasparente.
(Materiale Plastico Riciclabile)

*Coffe table with transparent methacrylate shelf.
Methacrylate structure available in two versions: black base with transparent top - opaline white base with transparent top.
(Recyclable Plastic Material)*





BARICCO

design by UTE

CL 275 - Ø50 H 41 cm

Tavolino in metacrilato trasparente. Top nei colori:
fumè, satinato, trasparente.
(Materiale Plastico Riciclabile)

*Methacrylate table, transparent base. Top available in
grey, opaline white or transparent.
(Recyclable Plastic Material)*





GLOVE

design by UTE

CL 218 SX - L 40 P 33 H 60 cm

Complemento multifunzione (tavolino, comodino, portariviste)
in metacrilato trasparente, particolare nel colore nero o bianco.
(Materiale Plastico Riciclabile)

*Small table and/or magazine rack and/or bedside table.
Inner element in black or white.
(Recyclable Plastic Material)*



GLOVE

design by UTE

CL 217 DX - L 40 P 33 H 60 cm





TRIONFO

design by **Walter Sbicca**

CL 2036 - L 40 P 33 49 cm

*Bedside table. Transparent methacrylate structure.
Details in chrome-plated brass, wood drawer available in:
natural grey - polar white - black - maple mondial.
(Recyclable Plastic Material)*

Comodino. struttura in metacrilato trasparente.
Particolari in ottone cromato, cassetto in legno nobilitato
disponibile nei colori : natural grey- bianco polar- nero -
acero mondial. (Materiale Plastico Riciclabile)



TRIONFO

design by **Walter Sbicca**

CL 2038 - L 40 P 33 49 cm

Comodino. struttura in metacrilato nero.
Particolari in ottone cromato, cassetto in legno nobilitato
disponibile nei colori : natural grey- bianco polar- nero -
acero mondial. (Materiale Plastico Riciclabile)

*Bedside table. Black methacrylate structure.
Details in chrome-plated brass, wood drawer available in:
natural grey - polar white - black - maple mondial.
(Recyclable Plastic Material)*



TRIONFO

design by **Walter Sbicca**

CL 2037 - L 40 P 33 49 cm

*Bedside table. Opaline white methacrylate structure.
Details in chrome-plated brass, wood drawer available in:
natural grey - polar white - black - maple mondial.
(Recyclable Plastic Material)*

Comodino. struttura in metacrilato satinato.
Particolari in ottone cromato, cassetto in legno nobilitato
disponibile nei colori : natural grey- bianco polar- nero -
acero mondial. (Materiale Plastico Riciclabile)





NAIF 12

design by UTE

CL 2045 - L 40 P 33 49 cm

*Bedside table. Black methacrylate structure.
Details in chrome-plated brass, wood drawer available in:
natural grey - polar white - black - maple mondial.
(Recyclable Plastic Material)*

Comodino. struttura in metacrilato nero.
Particolari in ottone cromato, cassetto in legno nobilitato
disponibile nei colori : natural grey- bianco polar- nero -
acero mondial. (Materiale Plastico Riciclabile)



NAIF 11

design by UTE

CL 2044 - L 40 P 33 49 cm

Comodino. struttura in metacrilato satinato.
Particolari in ottone cromato, cassetto in legno nobilitato
disponibile nei colori : natural grey- bianco polar- nero -
acero mondial. (Materiale Plastico Riciclabile)

*Bedside table. Opaline white methacrylate structure.
Details in chrome-plated brass, wood drawer available in:
natural grey - polar white - black - maple mondial.
(Recyclable Plastic Material)*



NAIF 10

design by UTE

CL 2043 - L 40 P 33 49 cm

*Bedside table. Transparent methacrylate structure.
Details in chrome-plated brass, wood drawer available in:
natural grey - polar white - black - maple mondial.
(Recyclable Plastic Material)*

Comodino. struttura in metacrilato trasparente.
Particolari in ottone cromato, cassetto in legno nobilitato
disponibile nei colori : natural grey- bianco polar- nero -
acero mondial. (Materiale Plastico Riciclabile)





A pair of elegant, dark-colored candle holders, each holding a single white candle. They are positioned on the top surface of the acrylic table.

A pair of black-rimmed glasses resting on an open book on the top surface of the acrylic table.

A stack of books on the lower shelf of the acrylic table. The visible titles include "Don Chisciotte della Mancia" by Cervantes, "L'Uomo di Corinto" by Umberto Eco, and "L'Uomo di Corinto" by Umberto Eco.

A bed with white and grey pillows, partially visible on the right side of the frame, adjacent to the acrylic table.

NAIF 1

design by UTE

CL 199 (Comodino / Bedside table) - L 49,5 P 36 H 57 cm

Comodino in metacrilato trasparente (spessore 8 mm).
(Materiale Plastico Riciclabile)

*Transparent methacrylate bedside table (thickness 8 mm).
(Recyclable Plastic Material)*

Particolare // Detail



CL 202 - L 48 P 34 cm

RIPIANO PER NAIF / SHELF FOR NAIF CL 199 E / AND CL 200

*Top shelf of methacrylate, in white or black colour (thickness 3 mm).
(Recyclable Plastic Material)*

Ripiano superiore per la serie dei complementi naif,
disponibile in metacrilato bianco e nero (spessore 3 mm).
(Materiale Plastico Riciclabile)

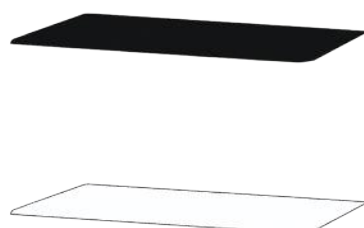



NAIF 2

design by UTE



CL 200 (Mobile alto / Bookcase)

L 49,5 P 36 H 90 cm

Mobile alto in metacrilato trasparente (spessore 8 mm).
(Materiale Plastico Riciclabile)

*Transparent methacrylate unit
(thickness of 8 mm).
(Recyclable Plastic Material)*

NAIF 3

design by UTE

CL 201 (Libreria / Bookcase)

L 71 P 30,5 H 90 cm

Libreria / Console in metacrilato trasparente spessore 8 mm.
(Materiale Plastico Riciclabile)

*Transparent methacrylate Bookcase /
Console table (thickness 8 mm).
(Recyclable Plastic Material)*



CL 203 - L 69 P 29 cm

RIPIANO PER NAIF / SHELF FOR NAIF CL 201

Ripiano superiore per la serie dei complementi naif, disponibile in metacrilato bianco e nero (spessore 3 mm).
(Materiale Plastico Riciclabile)

*Top shelf of methacrylate
in white or black colour (thickness 3 mm).
(Recyclable Plastic Material)*







NAIF 4

design by UTE

CL 208 (Piccolo / Small) - L 56 P 50 H 31 cm

Tavolino. Metacrilato trasparente spessore 10 mm.
Raffinato complemento ideale ovunque occorra
un tavolo di servizio in più. (portata max 20 kg)
(Materiale Plastico Riciclabile)

*Small table. Top and legs in methacrylate
(10 mm thickness). (max load 20 kg)
(Recyclable Plastic Material)*



NAIF 5

design by UTE

CL 209 (Grande / Big) - L 85 P 50 H 31 cm

Tavolino. Metacrilato trasparente spessore 12 mm.
Raffinato complemento ideale ovunque occorra un
tavolo di servizio in più. (portata max 20 kg)
(Materiale Plastico Riciclabile)

*Table. Top and legs in methacrylate (12 mm thickness).
(max load 20 Kg). (Recyclable Plastic Material)*







FINNY 1

design by UTE

CL 211 (Tondo basso / Small round) - Piano / Top D 50 H 33 cm

Tavolino rotondo in metacrilato trasparente, gambe in finitura acidata. (portata max 15 kg)
(Materiale Plastico Riciclabile)

*Round methacrylate table, opaline white table legs
(max load 15 Kg). (Recyclable Plastic Material)*



FINNY 2

design by UTE

CL 212 (Tondo alto / High round) - Piano / Top D 50 H 42 cm

Tavolino rotondo in metacrilato trasparente, gambe in finitura acidata. (portata max 15 kg).
(Materiale Plastico Riciclabile)

*Round methacrylate table, opaline white table legs.
(max load 15 Kg). (Recyclable Plastic Material)*



FINNY 4

design by UTE

CL 214 (Quadrato basso / Small square)

L 46 P 46 H 33 cm

Tavolino quadrato in metacrilato trasparente, gambe in finitura acidata. (portata max 15 kg).
(Materiale Plastico Riciclabile)

*Square methacrylate table, opaline white table legs.
(max load 15 Kg). (Recyclable Plastic Material)*



FINNY 5

design by UTE

CL 215 (Quadrato alto / High square)

L 50 P 50 H 42 cm

Tavolino quadrato in metacrilato trasparente, gambe in finitura acidata. (portata max 15 kg).
(Materiale Plastico Riciclabile)

*Square methacrylate table, opaline white table legs.
(max load 15 Kg). (Recyclable Plastic Material)*





FINNY 6

design by UTE

CL 216 (Rettangolare / Rectangular) - L 83 P 50 H 33 cm

Tavolino rettangolare in metacrilato trasparente,
gambe in finitura acidata. (portata max 15 kg).
(Materiale Plastico Riciclabile)

*Rectangular methacrylate table, opaline white table legs.
(max load 15 Kg). (Recyclable Plastic Material)*



ANDY 1

design by UTE

CL 982 - L 56 P 50 H 30 cm

Carrello multiuso su ruote in metacrilato trasparente.
(portata 20 kg). (Materiale Plastico Riciclabile)

*Multipurpose trolley in transparent methacrylate.
(max load 20 Kg). (Recyclable Plastic Material)*





ANDY 2

design by UTE

CL 983 - L 84 P 50 H 30 cm

Carrello multiuso su ruote in metacrilato trasparente.
(portata 30 kg). (Materiale Plastico Riciclabile)

*Multipurpose trolley in transparent methacrylate.
(max load 30 Kg). (Recyclable Plastic Material)*



ANDY 6

design by UTE

CL 097 - L 92 P 41 H 30 cm

Carrello multiuso su ruote in metacrilato trasparente.
(portata 30 kg). (Materiale Plastico Riciclabile)

*Multipurpose trolley in transparent methacrylate.
(max load 30 Kg). (Recyclable Plastic Material)*



ANDY 3

design by UTE

CL 984 - L 48 P 40 H 59 cm

Carrello multiuso su ruote in metacrilato trasparente.
(portata 20 kg). (Materiale Plastico Riciclabile)

*Multipurpose trolley in transparent methacrylate.
(max load 20 Kg). (Recyclable Plastic Material)*



ANDY 4

design by UTE

CL 095 - L 40 P 33 H 89 cm

Carrello multiuso su ruote in metacrilato trasparente.
(portata 30 kg). (Materiale Plastico Riciclabile)

*Multipurpose trolley in transparent methacrylate.
(max load 30 Kg). (Recyclable Plastic Material)*





ANDY 5

design by UTE

CL 096 - L 65 P 33 H 75 cm

Carrello multiuso su ruote in metacrilato trasparente.
(portata 30 kg). (Materiale Plastico Riciclabile)

*Multipurpose trolley in transparent methacrylate.
(max load 30 Kg). (Recyclable Plastic Material)*





CL 2052 - D 38 H 65 cm

Bedside table. Sandylex pearl structure in foamed PVC, available in: white pearl or texture: grey - multicolor- circles. (Recyclable Plastic Material)

Comodino in sandylex pearl. Struttura in PVC espanso, disponibile nelle versioni: bianco pearl o Texture: grigio - multicolor - bolli. (Materiale Plastico Riciclabile)



IDEO

design by UTE

CL 230 - L 53 P 33 H 48 cm

Tavolino portariviste: struttura in metacrilato trasparente, particolare in MDF laccato nei colori: nero e bianco. (Materiale Plastico Riciclabile)

Multipurpose unit in transparent methacrylate. Details in scratch-resistant lacquered wood. Available in black or white. (Recyclable Plastic Material)



ARROW

design by Lucia Pierini

CL 2005 - L 83 P 33 H 89 cm

*Transparent methacrylate console table.
Wall mounting. (Recyclable Plastic Material)*

Consolle in metacrilato trasparente spessore 12 mm.
Fissaggio a muro. (Materiale Plastico Riciclabile)





ARMONIA UNO

design by UTE

CL 1659 - L 100 P 33 H 80

Consolle in PMMA trasparente sp. 1,5 cm.
(Materiale Plastico Riciclabile)

*Console in transparent PMMA, thickness, 1,5 cm.
(Recyclable Plastic Material)*

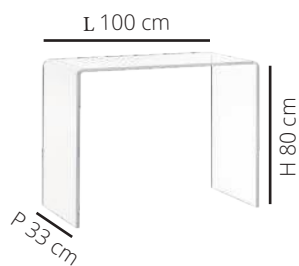

ARMONIA DUE

design by UTE

CL 1660 - L 80 P 40 H 75

Consolle in PMMA trasparente sp. 1,5 cm.
(Materiale Plastico Riciclabile)

*Console in transparent PMMA, thickness, 1,5 cm.
(Recyclable Plastic Material)*

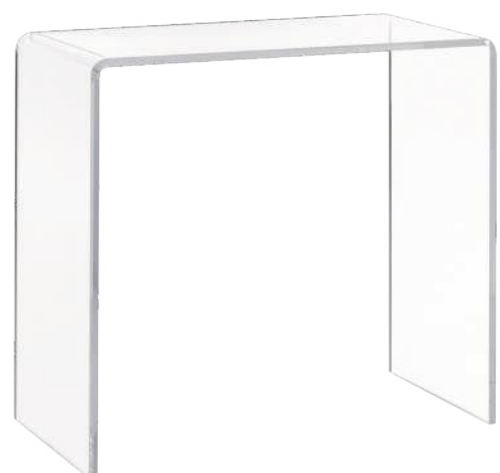
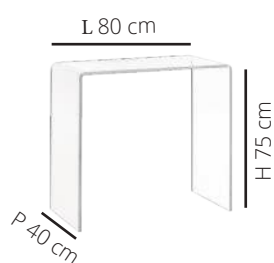



ARMONIA TRE

design by UTE

CL 1661 - L 80 P 40 H 75

Console in transparent PMMA. Thickness 1,5 cm. with shelf positioned at 12 cm. from the top, screws for fixing the chromed metal shelf. (Recyclable Plastic Material)

Consolle in PMMA trasparente sp. 1.5 cm. con mensola posizionata a 12 cm. dal piano, viti per fissaggio ripiano in metallo cromato. (Materiale Plastico Riciclabile)

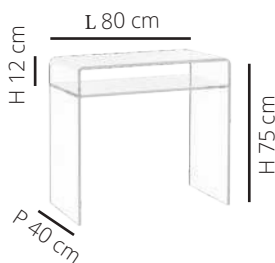

ARMONIA QUATTRO

design by UTE

CL 1662 - L 100 P 33 H 80

Console in transparent PMMA. Thickness 1,5 cm. with shelf positioned at 12 cm. from the top, screws for fixing the chromed metal shelf. (Recyclable Plastic Material)

Consolle in PMMA trasparente sp. 1.5 cm. con mensola posizionata a 12 cm. dal piano, viti per fissaggio ripiano in metallo cromato. (Materiale Plastico Riciclabile)

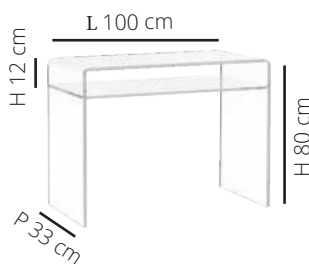

ARMONIA CINQUE

design by UTE

CL 1663 - L 120 P 33 H 80

Console in transparent PMMA. Thickness 1,5 cm. with shelf positioned at 12 cm. from the top, screws for fixing the chromed metal shelf. (Recyclable Plastic Material)

Consolle in PMMA trasparente sp. 1.5 cm. con mensola posizionata a 12 cm. dal piano, viti per fissaggio ripiano in metallo cromato. (Materiale Plastico Riciclabile)

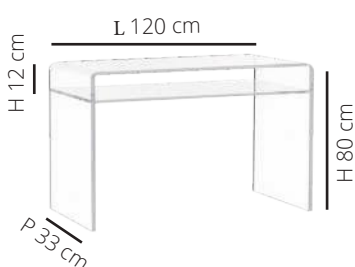



ARMONIA SEI

design by UTE

CL 1664 - L 100 P 33 H 75

Console in transparent PMMA. Thickness 1,5 cm. with shelf positioned at 25 cm. from the top, screws for fixing the chromed metal shelf. (Recyclable Plastic Material)

Consolle in PMMA trasparente sp. 1.2 cm. con mensola posizionata a 25 cm. dal piano, viti per fissaggio ripiano in metallo cromato (Materiale Plastico Riciclabile)



ARMONIA SETTE

design by UTE

CL 1665 - L 120 P 40 H 80

Console in transparent PMMA. Thickness 1,5 cm. with shelf positioned at 25 cm. from the top, screws for fixing the chromed metal shelf. (Recyclable Plastic Material)

Consolle in PMMA trasparente sp. 1.2 cm. con mensola posizionata a 25 cm. dal piano, viti per fissaggio ripiano in metallo cromato (Materiale Plastico Riciclabile)







NAIF 8

design by UTE

CL 2041 - L 33 P 33 H 68,5 cm

Sgabello alto. Struttura in metacrilato trasparente. Particolari in acciaio verniciato disponibile nei colori: grigio o metallizzato. (Materiale Plastico Riciclabile)

Tall stool. Transparent methacrylate structure. Details in in painted steel available in: grey or metallic. (Recyclable Plastic Material)



NAIF 6

design by UTE

CL 2039 - L 33 P 33 H 68,5 cm

Sgabello alto. Struttura in metacrilato sabbato. Particolari in acciaio verniciato disponibile nei colori: grigio o metallizzato. (Materiale Plastico Riciclabile)

Tall stool. Opaline white methacrylate structure. Details in in painted steel available in: grey or metallic. (Recyclable Plastic Material)





NAIF 9

design by UTE

CL 2042 - L 33 P 33 H 44 cm

Sgabello basso. Struttura in metacrilato trasparente. Particolari in acciaio verniciato disponibile nei colori: grigio o metallizzato. (Materiale Plastico Riciclabile)

Small stool. Transparent methacrylate structure. Details in in painted steel available in: grey or metallic. (Recyclable Plastic Material)



NAIF 7

design by UTE

CL 2040 - L 33 P 33 H 44 cm

Sgabello basso. Struttura in metacrilato sabbato. Particolari in acciaio verniciato disponibile nei colori: grigio o metallizzato. (Materiale Plastico Riciclabile)

Small stool. Opaline white methacrylate structure. Details in in painted steel available in: grey or metallic. (Recyclable Plastic Material)





TRIONFO

design by **Walter Sbicca**

CL 2035 - L 33 P 33 H 44 cm

Sgabello basso. Struttura in metacrilato trasparente.
Particolari in acciaio verniciato disponibile nei colori:
grigio o metallizzato. (Materiale Plastico Riciclabile)

*Small stool. Transparent methacrylate structure.
Details in in painted steel available in: grey or metallic.
(Recyclable Plastic Material)*



TRIONFO

design by **Walter Sbicca**

CL 2033 - L 33 P 33 H 44 cm

Sgabello basso. Struttura in metacrilato satinato.
Particolari in acciaio verniciato disponibile nei colori:
grigio o metallizzato. (Materiale Plastico Riciclabile)

*Small stool. Opaline white methacrylate structure.
Details in in painted steel available in: grey or metallic.
(Recyclable Plastic Material)*







TRIONFO

design by **Walter Sbicca**

CL 2034 - L 33 P 33 H 68,5 cm

Sgabello alto. Struttura in metacrilato trasparente. Particolari in acciaio verniciato disponibile nei colori: grigio o metallizzato. (Materiale Plastico Riciclabile)

Tall stool. Transparent methacrylate structure. Details in in painted steel available in: grey or metallic. (Recyclable Plastic Material)



TRIONFO

design by **Walter Sbicca**

CL 2032 - L 33 P 33 H 68,5 cm

Sgabello alto. Struttura in metacrilato satinato. Particolari in acciaio verniciato disponibile nei colori: grigio o metallizzato. (Materiale Plastico Riciclabile)

Tall stool. Opaline white methacrylate structure. Details in in painted steel available in: grey or metallic. (Recyclable Plastic Material)





AMBROGIO

design by **Walter Sbicca**

grigio pietra - stone grey



grigio cera - wax grey



acero mondial - maple mondial



CL 2049 - L 63 P 50 H 80 cm

Carrello cucina. Struttura in metacrilato trasparente, particolari in acciaio verniciato grigio ruote in alluminio pressofuso, ripiano in legno nobilitato disponibile nei colori: grigio pietra - grigio cera - bianco premium - acero mondial. (Materiale Plastico Riciclabile)

Kitchen trolley. Transparent methacrylate structure. Details in grey painted steel. Die-cast aluminium wheels. Wood shelf available in: stone grey - wax grey - premium white - maple mondial. (Recyclable Plastic Material)



bianco premium - premium white



AMBROGIO

design by **Walter Sbicca**

CL 2048 - L 63 P 50 H 80 cm

Carrello cucina. Struttura in metacrilato satinato particolari in acciaio verniciato grigio ruote in alluminio pressofuso, ripiano in legno nobilitato disponibile nei colori: grigio pietra - grigio cera - bianco premium - acero mondial. (Materiale Plastico Riciclabile)

Kitchen trolley. Opaline white methacrylate structure. Details in grey painted steel. Die-cast aluminium wheels. Wood shelf available in: stone grey - wax grey - premium white - maple mondial. (Recyclable Plastic Material)



grigio pietra - stone grey



grigio cera - wax grey



bianco premium - premium white



acero mondial - maple mondial







AMBROGIO

design by **Walter Sbicca**

grigio pietra - stone grey



grigio cera - wax grey



acero mondial - maple mondial



CL 2050 - L 63 P 50 H 80 cm

Carrello cucina. Struttura in metacrilato nero, particolari in acciaio verniciato grigio ruote in alluminio pressofuso, ripiano in legno nobilitato disponibile nei colori: grigio pietra - grigio cera - bianco premium - acero mondial. (Materiale Plastico Riciclabile)

Kitchen trolley. Black methacrylate structure. Details in grey painted steel. Die-cast aluminium wheels. Wood shelf available in: stone grey - wax grey - premium white - maple mondial. (Recyclable Plastic Material)



bianco premium - premium white



ONDINA

design by Romeo Guaricci

CL 2001 - L 50 P 52 H 90 cm

Carrello in metacrilato spessore 8 mm nei colori:
nero, satinato, trasparente.
(Materiale Plastico Riciclabile)

*Methacrylate trolley thickness 8 mm available
in black, opaline white and transparent.
(Recyclable Plastic Material)*



CANTINETTA 18

design by Romeo Guaricci

CL 2004 - L 25 P 10 H 153 cm

Portabottiglie in metacrilato trasparente sp 12 mm.
Fissaggio a muro. Contiene 18 bottiglie.
(Materiale Plastico Riciclabile)

*Wine rack in transparent methacrylate thickness 12 mm.
Wall mounting. It contains 18 bottles.
(Recyclable Plastic Material)*



CANTINETTA 15

design by Romeo Guaricci

CL 2003 - L 25 P 10 H 122 cm

Portabottiglie in metacrilato trasparente sp 12 mm.
Fissaggio a muro. Contiene 15 bottiglie.
(Materiale Plastico Riciclabile)

*Wine rack in transparent methacrylate thickness 12 mm.
Wall mounting. It contains 15 bottles.
(Recyclable Plastic Material)*





CL 150 (da parete / hanging version) - L 13,5 P 5,5 H 104 cm

Portabottiglie da parete in metacrilato, disponibile nei colori nero, satinato e trasparente. Contiene 12 bottiglie. (Materiale Plastico Riciclabile)

Methacrylate wine rack. Hanging version, available in black, opaline white and transparent. Wall mounting. It contains 12 bottles. (Recyclable Plastic Material)

Particolare // Detail



CL 149 (con base / ground version) - L 45 P 26 H 101 cm

Portabottiglie da terra in metacrilato con base in legno laccata bianca. Disponibile nei colori: nero, satinato e trasparente. Contiene 12 bottiglie. (Materiale Plastico Riciclabile)

Methacrylate wine rack. Floor version, available in black, opaline white and transparent. It contains 12 bottles. (Recyclable Plastic Material)



DUNE

design by **Lorenzo Radaelli**

CL 2056 - L 30 P 30 H 6 cm

Centrotavola di forma quadrata in metacrilato disponibile nei colori: trasparente - nero - bianco - rosso.
(Materiale Plastico Riciclabile)

*Square methacrylate adornment available in:
transparent - black - white - red.
(Recyclable Plastic Material)*

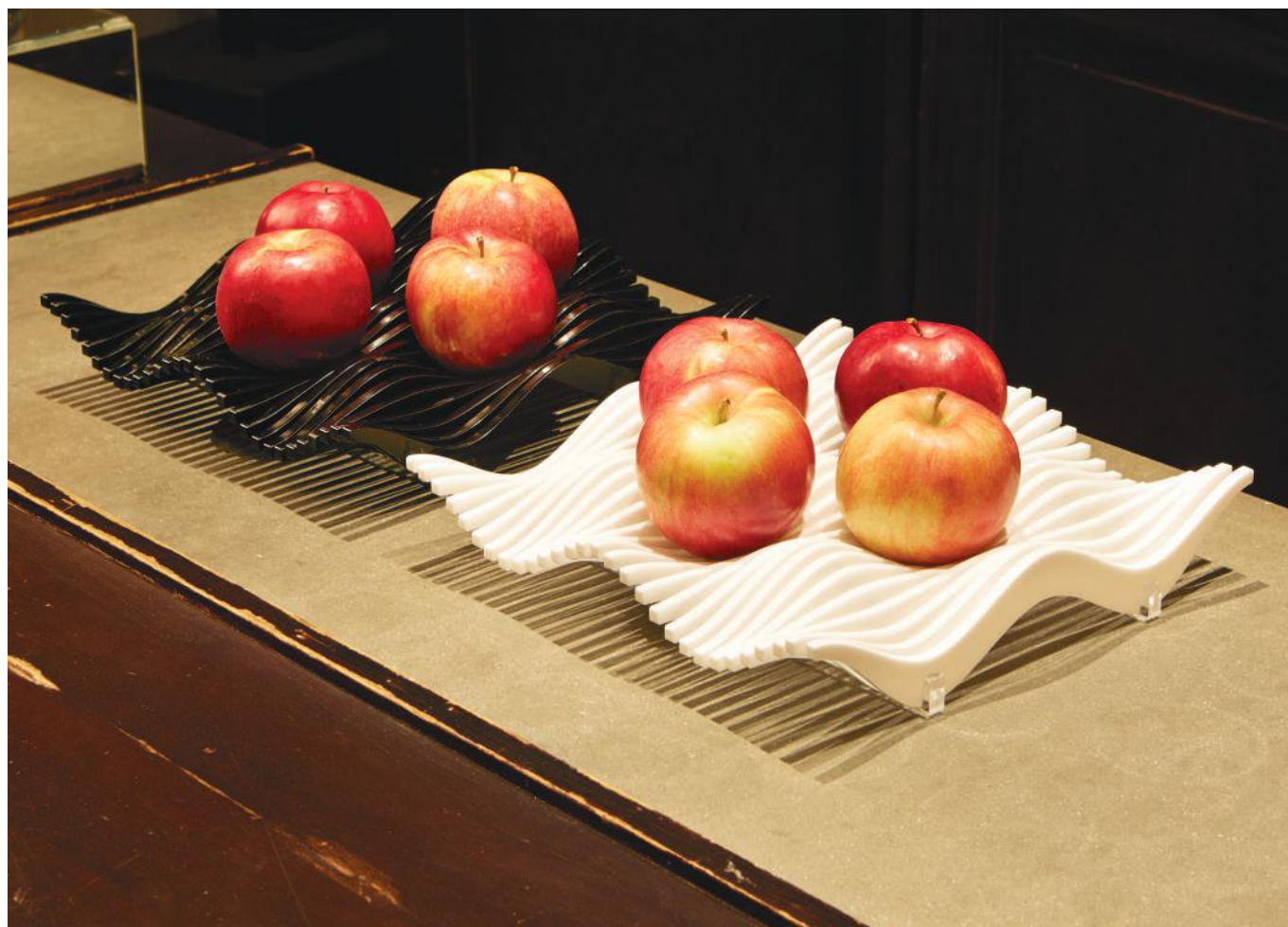
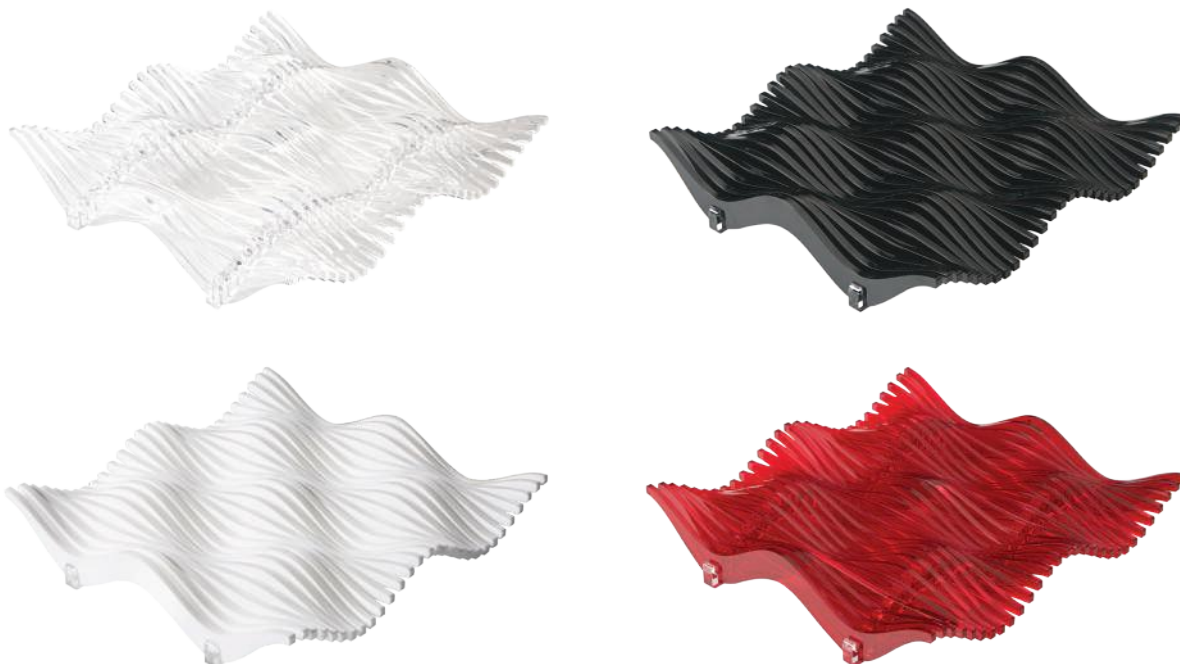

DUNE

design by **Lorenzo Radaelli**

CL 2057 - L 45 P 15 H 6 cm

*Small rectangular methacrylate adornment available in:
transparent - black - white - red.*

Centrotavola di forma rettangolare piccolo in metacrilato
disponibile nei colori: trasparente - nero - bianco - rosso.
(Materiale Plastico Riciclabile)

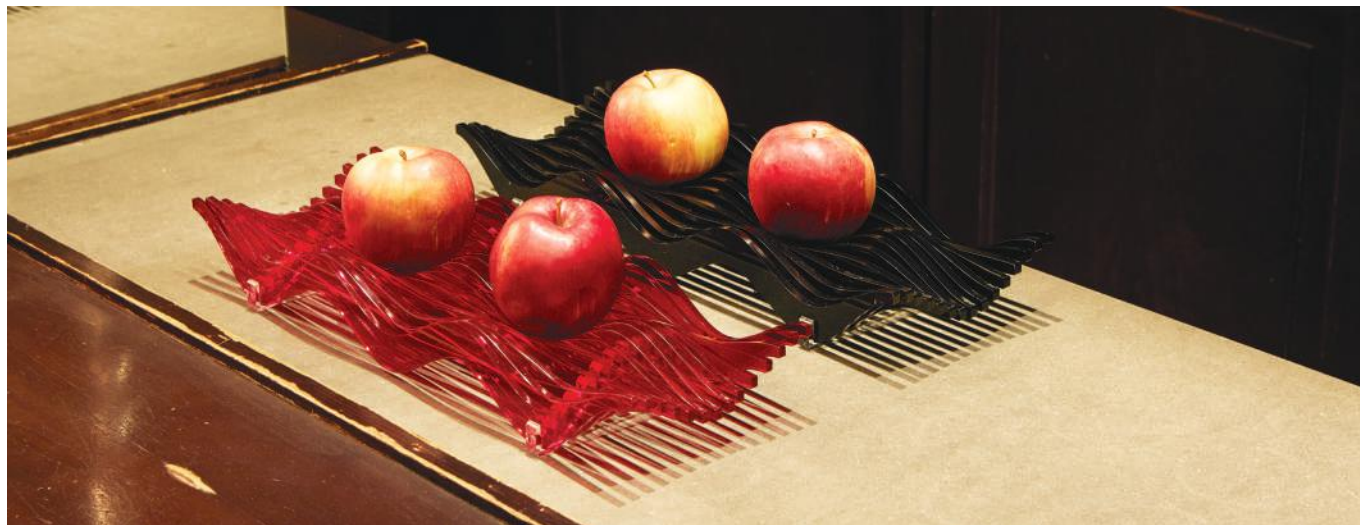

DUNE

design by **Lorenzo Radaelli**

CL 2058 - L 60 P 15 H 6 cm

*Big rectangular methacrylate adornment available in:
transparent - black - white - red.
(Recyclable Plastic Material)*

Centrotavola di forma rettangolare grande in metacrilato
disponibile nei colori: trasparente - nero - bianco - rosso.
(Materiale Plastico Riciclabile)

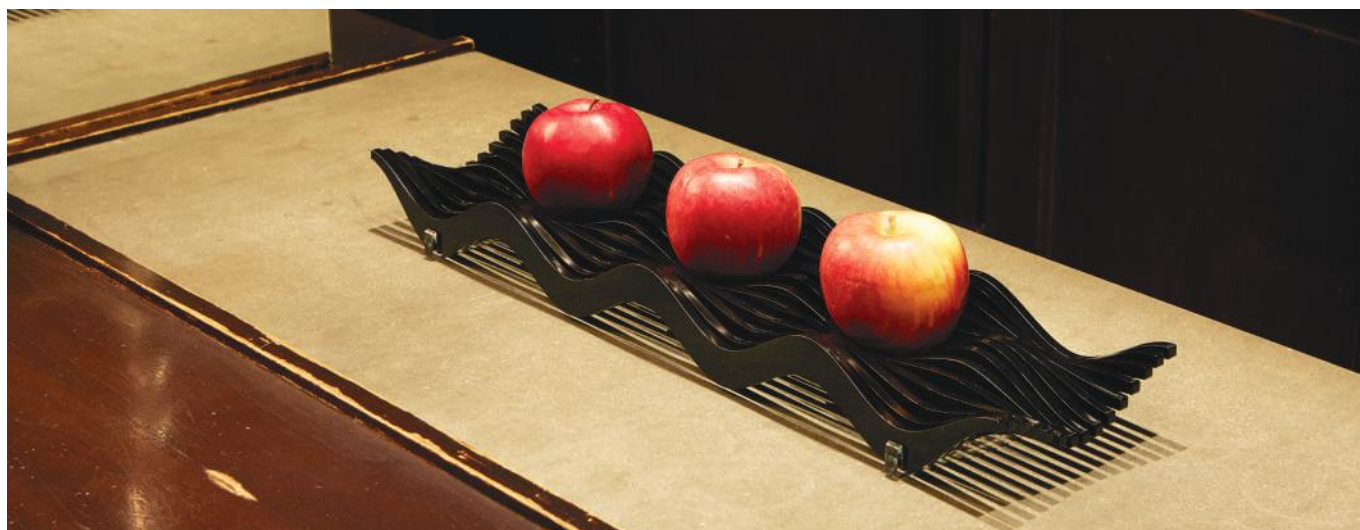

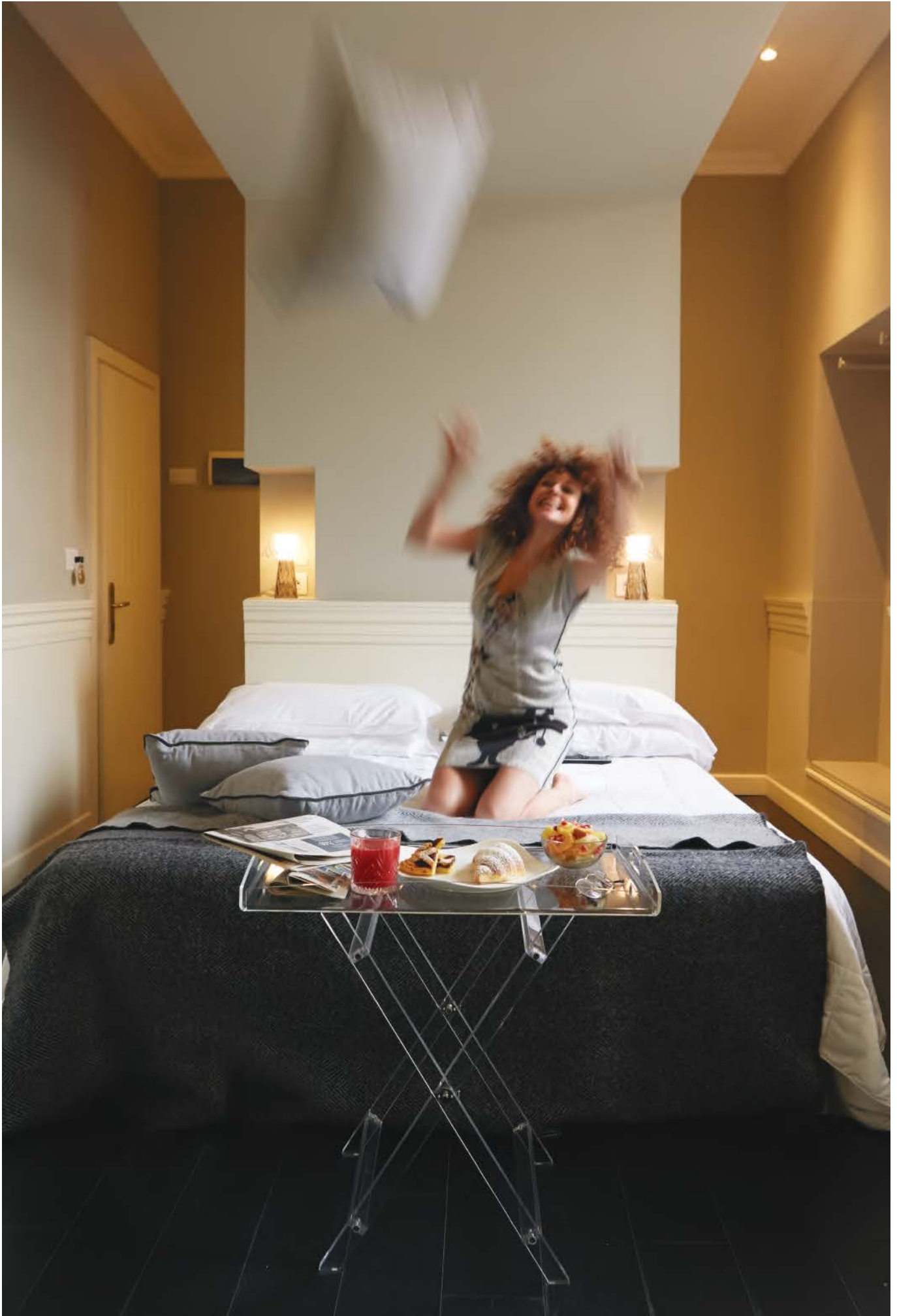

CAVALLETTO

design by UTE

Rectangular tray with support: Transparent methacrylate structure. Details in chromed steel, methacrylate tray available in : transparent - opaline white- smoked grey. (Recyclable Plastic Material)

CL 2047 - L 65 P 41 H 64 cm

Vassoio rettangolare con supporto.
Struttura in metacrilato trasparente.
Particolari in acciaio cromato,
vassoio in metacrilato disponibile nei colori :
trasparente - satinato - fumè.
(Materiale Plastico Riciclabile)







CAVALLETTO

design by UTE

CL 2046 - D 60 H 59 cm

Vassoio tondo con supporto. Struttura in metacrilato trasparente. Particolari in acciaio cromato, vassoio in metacrilato disponibile nei colori : trasparente - satinato - fumè. (Materiale Plastico Riciclabile)

Round tray with stand: transparent methacrylate structure. Details in chromed steel, available in colours : transparent - opaline white - smoked grey. (Recyclable Plastic Material)





QUASIMODO WOOD

design by UTE

CL 838 - L 48 P 29 H 110 cm

Servomuto con struttura in metallo verniciato colore bianco, particolari in metacrilato trasparente, base e pomello in legno naturale.
(Materiale Plastico Riciclabile)

Valet stand, white painted metal structure. Details in transparent methacrylate, base and knob in natural wood.
(Recyclable Plastic Material)

Particolare // Detail



QUASIMODO CRILUX

design by UTE

CL 905 - L 48 P 29 H 110 cm

Servomuto con struttura in metallo verniciato colore grigio, particolari in metacrilato nei colori satinato e trasparente. Dettagli in finitura cromata.
(Materiale Plastico Riciclabile)

Valet stand, grey painted metal structure. Methacrylate details available in opaline white and transparent. Chromed details.
(Recyclable Plastic Material)



ROBIN

design by UTE

CL 4023 - L 43 P 32 H 113 cm

Servomuto in metacrilato trasparente.
Asta verniciata effetto cromo e base in
MDF laccato argento.
(Materiale Plastico Riciclabile)

*Valet stand in transparent methacrylate.
Silver base and painted metal structure.
(Recyclable Plastic Material)*

Particolare // Detail



MANHATTAN

design by Romeo Guaricci

CL 2002 - Ø40 H 170 cm

Appendiabiti in metacrilato sp 8 mm nei colori:
nero, satinato e trasparente.
(Materiale Plastico Riciclabile)

*Clothes hanger in methacrylate thickness 8 mm available
in black, opaline white and transparent.
(Recyclable Plastic Material)*



MIKADO

design by UTE

CL 835 - D 40 H 184 cm

Appendiabiti bianco.
Particolari in legno naturale,
pomelli in ABS verniciato bianco.
(Materiale Plastico Riciclabile)

*Clothes hanger in white colour.
Details in natural wood, white knobs.
(Recyclable Plastic Material)*

Particolare // Detail



KEBAB

design by UTE

CL 159 - D 40 H 180 cm

Appendiabiti bianco, particolari cromati.
(Materiale Plastico Riciclabile)

*Clothes hanger in white painted metal. Chromed details.
(Recyclable Plastic Material)*



IKEBANA

design by UTE

CL 712 - D 40 H 180 cm

Appendiabiti nel colore grigio,
particolari in metacrilato nei colori
rosso, trasparente e satinato.
(Materiale Plastico Riciclabile)

*Clothes hanger in grey colour.
Methacrylate details available in
red, transparent and opaline white.
(Recyclable Plastic Material)*





JUTA WOOD

design by UTE

CL 836 - D 40 H 174 cm

Appendiabiti in metallo verniciato colore bianco, particolari e base in legno naturale.
(Materiale Plastico Riciclabile)

*Clothes hanger in painted metal coated white.
Base and details in natural wood.
(Recyclable Plastic Material)*



JUTA

design by UTE

CL 227 - D 40 H 174 cm

Appendiabiti in metallo verniciato bianco.
Base in MDF laccato bianco.
(Materiale Plastico Riciclabile)

*Clothes hanger in white painted metal.
MDF base in lacquered white.
(Recyclable Plastic Material)*





ERBAVOGLIO FAMILY

design by UTE

CL 033 - D 40 H 61 cm

Fioriera da terra in polietilene con riserva d'acqua nei colori bianco e grigio e struttura portante in metacrilato trasparente. (Materiale Plastico Riciclabile)

Ground flower box in polyethylene with water supply, available in white and silver. Methacrylate base. (Recyclable Plastic Material)



CL 034 - D 40 H 34 cm

Fioriera da terra in polietilene con riserva d'acqua nei colori bianco e grigio e struttura portante in metacrilato trasparente. (Materiale Plastico Riciclabile)

Ground flower box in polyethylene with water supply, available in white and silver. Methacrylate base. (Recyclable Plastic Material)





ERBAVOGLIO FAMILY

design by UTE

CL 036 - L 68 P 40 H 75 cm

Fioriera da soffitto in polietilene con riserva d'acqua nei colori bianco e grigio e struttura portante in metacrilato trasparente.

(Materiale Plastico Riciclabile)

Hanging flower box in polyethylene with water supply, available in white and silver. Methacrylate structure.
(Recyclable Plastic Material)



CL 035 - L 40 P 50 H 26 cm

Fioriera da parete in polietilene con riserva d'acqua nei colori bianco e grigio e struttura portante in metacrilato trasparente.

(Materiale Plastico Riciclabile)

Hanging flower box in polyethylene with water supply, available in white and silver. Transparent methacrylate base.
(Recyclable Plastic Material)



CL 041 - L 47 P 40 H 25 cm

Modulo Fioriera fissaggio a soffitto in polietilene con riserva d'acqua, stampata in rotazionale disponibile nei colori : Bianco e Grigio.
Supporto in metacrilato trasparente spessore 10 mm.
Cavo sostegno cm. 280
(in dotazione morsetti per montaggio multiplo e modulare)
(Materiale Plastico Riciclabile)

*Hanging ceiling flowertray of rotational-moulded polyethylene with water supply, available white and silver colour, base of methacrylate (thickness 10 mm).
Lenght cable cm 280.
(Clamps for multiple and modular assembly included)
(Recyclable Plastic Material)*



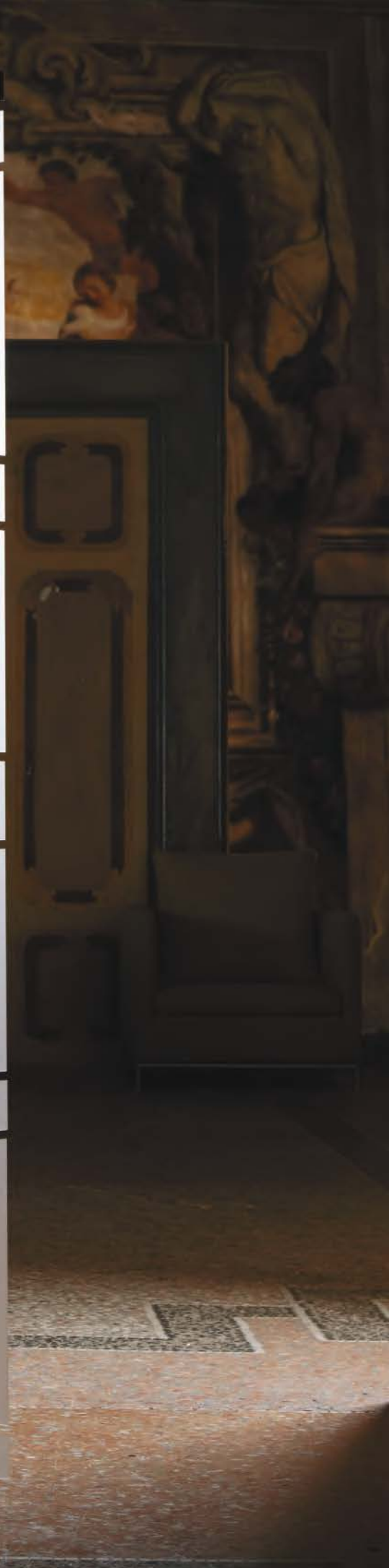

PAREO WHITE

design by UTE

CL 860 - L 75 P 22 H 198 cm

Separè in metacrilato bianco satinato.
Struttura e base in metallo verniciato colore bianco.
(Materiale Plastico Riciclabile)

*Methacrylate privacy screen in opaline white.
Structure and base in painted metal coated white.*
(Recyclable Plastic Material)



PAREO

design by UTE

CL 031 - L 75 P 22 H 198 cm

Separè in metacrilato, disponibile nei colori rosso e satinato.
Struttura e base in metallo verniciato colore grigio.
(Materiale Plastico Riciclabile)

*Methacrylate privacy screen available in red and opaline white.
Structure and base in painted metal coated grey.*
(Recyclable Plastic Material)



TELAIO

design by UTE

CL 020 - L 75 P 4 H 207 cm

Separè in metacrilato con fissaggio a sospensione.
Disponibile nei colori rosso e satinato.
(Materiale Plastico Riciclabile)

*Methacrylate hanging privacy screen available
in red and opaline white.*
(Recyclable Plastic Material)



POP WOOD

design by UTE

CL 830 - D 40 H 173 cm

Scarpiera in polipropilene bianco perla con 11 scomparti.
Base e top in legno naturale.
(Materiale Plastico Riciclabile)

*Pearl white polypropylene shoe rack with 11 shelves.
Base and top in natural wood.
(Recyclable Plastic Material)*



[120]

POP WHITE

design by UTE

CL 850 - D 40 H 173 cm

Scarpiera in polipropilene bianco perla con 11 scomparti.
Base e top in metallo verniciato bianco.
(Materiale Plastico Riciclabile)

*Pearl white polypropylene shoe rack with 11 shelves.
Base and top in white painted metal.
(Recyclable Plastic Material)*



POP

design by UTE

CL 700 - D 40 H 173 cm

Scarpiera in polipropilene con 11 scomparti. Base e top in metallo verniciato grigio. Disponibile nei colori: opalino e grigio. (Materiale Plastico Riciclabile)

Pearl white polypropylene shoe rack with 11 shelves. Base and top in grey painted metal. Available in opaline white and grey. (Recyclable Plastic Material)



METALPOP

design by UTE

CL 900 - D 40 H 173 cm

Scarpiera e contenitore universale in acciaio verniciato a polveri epossidiche con 11 scomparti. Disponibile nei colori grigio alluminio o bianco. (Materiale Plastico Riciclabile)

Shoe rack in epoxy powder painted steel with 11 shelves. Available in grey and white. (Recyclable Plastic Material)



CL 750 - L/W 30 H 167 P/D 36 cm

Scarpiera 10 cassetti in polipropilene bianco perla.
Base e top in metallo verniciato bianco.
(Materiale Plastico Riciclabile)

*Shoe rack with 10 drawers in pearl white polypropylene.
Top and base in white painted metal.
(Recyclable Plastic Material)*



CL 751 - L/W 30 H 170 P/D 36 cm

Scarpiera 10 cassetti con ruote in polipropilene bianco perla. Base, top in metallo verniciato bianco.
(Materiale Plastico Riciclabile)

*Shoe rack with 10 drawers and wheels in pearl white polypropylene. Top and base in white painted metal.
(Recyclable Plastic Material)*





FLUIDA WOOD

design by UTE

CL 832 (10 cassetti/drawers) - L 41 P 25,5 H 168 cm

CL 831 (6 cassetti/drawers) - L 41 P 25,5 H 104 cm

Scarpiera, contenitore multiuso in polipropilene bianco perla, base e top in legno naturale. (Materiale Plastico Riciclabile)

Shoe rack, multipurpose unit in pearl white polypropylene. Base and top in natural wood. (Recyclable Plastic Material)



FLUIDA WHITE

design by UTE

CL 852 (10 cassetti/drawers) - L 41 P 25,5 H 168 cm

CL 851 (6 cassetti/drawers) - L 41 P 25,5 H 104 cm

Scarpiera, contenitore multiuso in polipropilene bianco perla
particolari in metallo verniciato colore bianco.
(Materiale Plastico Riciclabile)

*Shoe rack, multipurpose unit in pearl white polypropylene.
Painted details coated white. (Recyclable Plastic Material)*



FLUIDA

design by UTE

CL 741 (10 cassetti/drawers) - L 41 P 25,5 H 168 cm

CL 742 (6 cassetti/drawers) - L 41 P 25,5 H 104 cm

Scarpiera, contenitore multiuso in polipropilene nei colori opalino
e grigio, particolari in metallo verniciato colore grigio.
(Materiale Plastico Riciclabile)

*Shoe rack, multipurpose unit in polypropylene, available
in opaline white and grey. Painted details coated grey.
(Recyclable Plastic Material)*



ISOTTA WOOD

design by UTE

CL 833 - L 44 P 35 H 57 cm

Cassettiera in filo metallico verniciato effetto cromo, con 3 cassetti in polipropilene bianco perla. Top in legno naturale. (Materiale Plastico Riciclabile)

Drawer unit. Painted metal frame. N. 3 drawers in pearl white polypropylene. Top in natural wood. (Recyclable Plastic Material)



CL 834 - L 44 P 35 H 106 cm

Cassettiera in filo metallico verniciato effetto cromo, con 6 cassetti in polipropilene bianco perla. Top in legno naturale. (Materiale Plastico Riciclabile)

Drawer unit. Painted metal frame. N. 6 drawers in pearl white polypropylene. Top in natural wood. (Recyclable Plastic Material)



ISOTTA

design by UTE

CL 715 - L 44 P 35 H 57 cm

Cassettiera in filo metallico verniciato effetto cromo, con 3 cassetti in polipropilene nei colori opalino e grigio. Top laccato grigio. (Materiale Plastico Riciclabile)

Drawer unit. Painted metal frame. N. 3 drawers in opaline white and grey polypropylene. Painted top coated grey. (Recyclable Plastic Material)



CL 717 - L 44 P 35 H 106 cm

Cassettiera in filo metallico verniciato effetto cromo, con 6 cassetti in polipropilene nei colori opalino e grigio. Top laccato grigio. (Materiale Plastico Riciclabile)

Drawer unit. Painted metal frame. N. 6 drawers in opaline white and grey polypropylene. Painted top coated grey. (Recyclable Plastic Material)



ISOTTA WHITE

design by UTE

CL 854 - L 44 P 35 H 106 cm

Cassettiera in filo metallico verniciato effetto cromo, con 6 cassetti in polipropilene bianco perla.

Top in MDF laccato bianco.
(Materiale Plastico Riciclabile)

Drawer unit. Painted metal frame. N. 6 drawers in pearl white polypropylene. Painted MDF top coated white. (Recyclable Plastic Material)



CL 853 - L 44 P 35 H 57 cm

Cassettiera in filo metallico verniciato effetto cromo, con 3 cassetti in polipropilene bianco perla.

Top in MDF laccato bianco.
(Materiale Plastico Riciclabile)

Drawer unit. Painted metal frame. N. 3 drawers in pearl white polypropylene. Painted MDF top coated white. (Recyclable Plastic Material)



CL 856 - L 44 P 35 H 106 cm

Cassettiera in filo metallico verniciato effetto cromo con 6 cassetti in polipropilene bianco perla. Top in MDF laccato bianco. Maniglie numeriche.
(Materiale Plastico Riciclabile)

Drawer unit. Painted metal frame. N. 6 drawers in pearl white polypropylene. Painted MDF top coated white. Number-shaped handles. (Recyclable Plastic Material)



CONTESSA

design by UTE

CL 855 - L 44 P 35 H 57 cm

Cassettiera in filo metallico verniciato effetto cromo con 3 cassetti in polipropilene bianco perla. Top in MDF laccato bianco. Maniglie numeriche.
(Materiale Plastico Riciclabile)

Drawer unit. Painted metal frame. N. 3 drawers in pearl white polypropylene. Painted MDF top coated white. Number-shaped handles. (Recyclable Plastic Material)



RASKY

design by Mammini Candido



Bianco pearl
Pearl white



Rosso
Red



Bronzo
Bronze



Multicolor





CL 2061 - L 59 P 21 H 62 cm

Contenitore multiuso grande in sandylex con supporti in PVC espanso disponibile nelle versioni : bianco pearl con texture bronzo - rosso - multicolor. (Materiale Plastico Riciclabile)

Big multipurpose container in sandylex with PVC foam supports available in : pearl white with bronze texture - red - multicolor texture. (Recyclable Plastic Material)



CL 2060 - L 47 P 17 H 49,5 cm

Contenitore multiuso medio in sandylex con supporti in PVC espanso disponibile nelle versioni : bianco pearl con texture bronzo - rosso - multicolor. (Materiale Plastico Riciclabile)

Medium multipurpose container in sandylex with PVC foam supports available in : pearl white with bronze texture - red - multicolor texture. (Recyclable Plastic Material)



CL 2059 - L 43 P 15 H 44,5 cm

Contenitore multiuso piccolo in sandylex con supporti in PVC espanso disponibile nelle versioni : bianco pearl con texture bronzo - rosso - multicolor. (Materiale Plastico Riciclabile)

Small multipurpose container in sandylex with PVC foam supports available in : pearl white with bronze texture - red - multicolor texture. (Recyclable Plastic Material)



INDIFFERENZIATO

design by **Walter Sbicca**

CL 2055 - L 55 P 40 H 112 cm

Waste collection container. Dark grey lacquered base and metal support, PVC foam and sandylex details available in: white pearl- grey. (Recyclable Plastic Material)

Contenitore raccolta indifferenziata. Materiali: base e asta sostegno in metallo laccato grigio scuro, particolari in PVC espanso e sandylex disponibile nei colori: bianco pearl - grigio. (Materiale Plastico Riciclabile)



CONICO

design by UTE

CL 841 - D 38 H 60 cm

Portabiancheria, contenitore in polipropilene bianco perla. Coperchio in legno naturale.
(Materiale Plastico Riciclabile)

*Laundry basket in pearl white polypropylene.
Top in natural wood. (Recyclable Plastic Material)*



ALCHIMILLO

design by UTE

CL 827 - D 30 H 42 cm

Cestino gettacarte in polipropilene nei colori opalino e grigio.
(Materiale Plastico Riciclabile)

*Wastepaper basket in polypropylene available in opaline white and grey.
(Recyclable Plastic Material)*



ARCHIMEDE

design by UTE

CL 859 - D 30 H 42 cm

Cestino gettacarte in polipropilene bianco perla.
(Materiale Plastico Riciclabile)

*Wastepaper basket in pearl white polypropylene.
(Recyclable Plastic Material)*





CL 2014 - L 33 P 42 H 96 cm

Portabiancheria: corpo in polipropilene bianco, fondo coperchio e top in vinilico bianco.
(Materiale Plastico Riciclabile)

*Laundry basket in white polypropylene. White vinylic lid.
(Recyclable Plastic Material)*



CL 2015 - L 33 P 42 H 96 cm

Portabiancheria :corpo in polipropilene bianco, con decoro nelle versioni:
texture foglia 91, texture sassi 94, fondo coperchio e top in vinilico bianco.
(Materiale Plastico Riciclabile)

*Laundry basket in white polypropylene available in:
leaves texture 91 and stones texture 94. White vinylic lid.
(Recyclable Plastic Material)*





COROLLA

design by Nicola Cerasa

CL 2016 - Ø 48 H 60 cm

Portabiancheria: corpo in polipropilene bianco, fondo e coperchio in vinilico bianco.
(Materiale Plastico Riciclabile)

*Laundry basket in white polypropylene. White vinylic lid.
(Recyclable Plastic Material)*



CL 2017 - Ø 48 H 60 cm

Portabiancheria: corpo in polipropilene bianco, fondo e coperchio in vinilico bianco.
Coperchio con decoro disponibile nelle versioni: texture foglia e texture sassi.
(Materiale Plastico Riciclabile)

*Laundry basket in white polypropylene.
White vinylic lid available in: leaves texture and stones texture.
(Recyclable Plastic Material)*



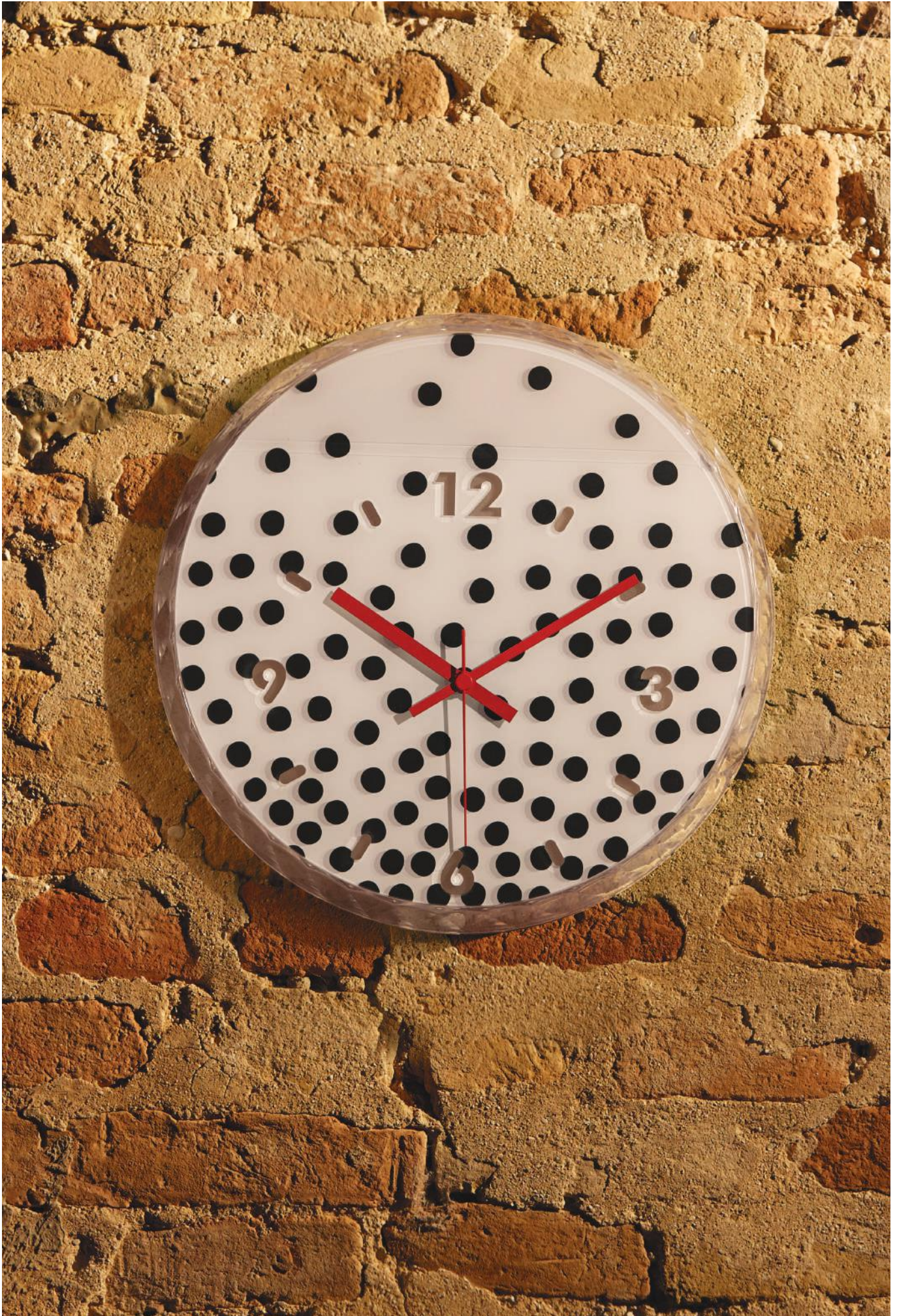

CL 2022 - Ø 36 H 7 cm

Orologio da parete: supporto in materiale acrilico, quadrante in PMMA metacrilato.
Texture, disponibile nelle versioni:
bolli trasparente, trama verde, foglia rosso, piuma blu, rombi multicolor.
Movimenti orologio al quarzo. (Materiale Plastico Riciclabile)

*Wall clock: acrylic support, methacrylate clock face available in:
texture with transparent balls, green texture, texture with red leaves,
blue feather, multicolors rhombus. (Recyclable Plastic Material)*

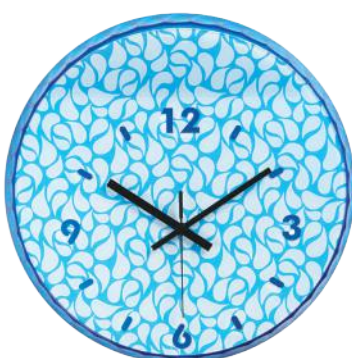



CL 2012 - L 52 P 10 H 73 cm

Specchio: struttura in multistrati betulla, verniciato trasparente opaco, decorato in stampa digitale.
Supporto specchio in metallo verniciato bianco.
(Materiale Plastico Riciclabile)

*Mirror with birch painted structure and digital printing.
White coated metal support. (Recyclable Plastic Material)*



KING AND QUEEN

design by Mammini Candido

CL 2063 - L 67 P 57 H 44

Grande - Large

CL 2062 - L 51 P 44 H 35

Piccolo - Small

Lettino per cani e gatti in sandylex bianco pearl e PVC espanso.
(Materiale Plastico Riciclabile)

*Bed for dogs and cats in white pearl sandylex and PVC foam.
(Recyclable Plastic Material)*



KING AND QUEEN

design by Mammini Candido



KING AND QUEEN

design by Mammini Candido



KING AND QUEEN

design by Mammini Candido



Cushions in 100% cotton, padding in cotton wool, easily washable by hand or washing machine. Available in: orange - blue. Cm. 51x35 (Decorations and fabrics can change according to available stock). (Recyclable Plastic Material)

CL 2066 - L 67 P 44 H 9

Grande - Large

Cuscini in 100% cotone , con imbottitura in ovatta, facilmente lavabile a mano o in lavatrice. Disponibile nei colori: arancio - blu. Cm. 51x35 (Decorati e colori possono cambiare in base alla disponibilità dei tessuti). (Materiale Plastico Riciclabile)

CL 2065 - L 51 P 35 H 9

Piccolo - Small



LAPILLO

design by UTE

CL 509 - L 34 P 28 H 38 cm

Portariviste: struttura in filo metallico nei colori nero, bianco e argento. Particolare in polipropilene pearl. (Materiale Plastico Riciclabile)

Magazine rack. Powder coated metal structure available in black, white and silver. White pearl polipropylene details. (Recyclable Plastic Material)



PLUVIO

design by UTE

CL 504 - D 27 H 64 cm

Umbrella stand in white pearl polipropylene. Powder coated metal structure available in black, silver and white. (Recyclable Plastic Material)

Portaombrelli: struttura in filo metallico nei colori nero, argento e bianco. Particolare in polipropilene bianco perla. (Materiale Plastico Riciclabile)



NICHEL WHITE

design by UTE

CL 857 - L 36 P 22 H 46 cm

Portariviste in polipropilene bianco perla.
(Materiale Plastico Riciclabile)

Magazine rack in pearl white polypropylene.
(Recyclable Plastic Material)



NICHEL

design by UTE

CL 763 - L 36 P 22 H 46 cm

Portariviste in polipropilene nei colori grigio e opalino.
(Materiale Plastico Riciclabile)

Magazine rack in grey or white polypropylene.
(Recyclable Plastic Material)



CROMO WHITE

design by UTE

CL 858 - L 36 P 22 H 75 cm

Portaombrelli in polipropilene bianco.
(Materiale Plastico Riciclabile)

Umbrella stand in pearl white polypropylene.
(Recyclable Plastic Material)



CROMO

design by UTE

CL 764 - L 36 P 22 H 75 cm

Portaombrelli in polipropilene disponibile nei colori opalino e grigio.
(Materiale Plastico Riciclabile)

Umbrella stand in polypropylene in opaline white and grey.
(Recyclable Plastic Material)



BIBAI

design by UTE

CL 093 - L 35 P 17 H 30 cm

Portariviste. Struttura in metacrilato trasparente.
Vaschetta nei colori: trasparente, satinato e rosso.
(Materiale Plastico Riciclabile)

*Magazine rack. Structure in transparent methacrylate.
Bowl available in transparent, opaline white and red.
(Recyclable Plastic Material)*



IKEDA

design by UTE

CL 092 - L 25 P 17 H 60 cm

Portaombrelli in metacrilato trasparente.
Vaschetta in metacrilato, disponibile nei colori
trasparente, satinato e rosso.
(Materiale Plastico Riciclabile)

*Methacrylate umbrella stand.
Bowl available in transparent,
opaline white and red.
(Recyclable Plastic Material)*



BAU

design by UTE

CL 4012 - L 48 P 13 H 43 cm

Portariviste in metacrilato colori trasparente, satinato, nero.
(Materiale Plastico Riciclabile)

*Methacrylate magazine rack available in transparent, opaline white,
black.* (Recyclable Plastic Material)



BAG

design by UTE

CL 4013 - L 33 P 15 H 37 cm

Portariviste in metacrilato trasparente nei colori:
nero, rosso, blu, fucsia, verde, bianco.
(Materiale Plastico Riciclabile)

*Magazine rack in transparent metacrylate available
in black, red, blue, fuchsia, green, white.
(Recyclable Plastic Material)*

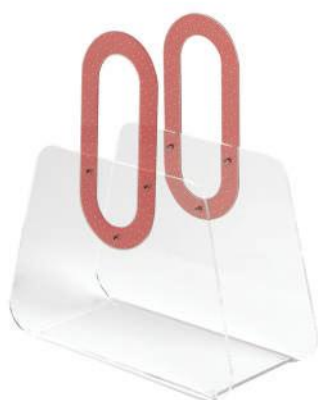
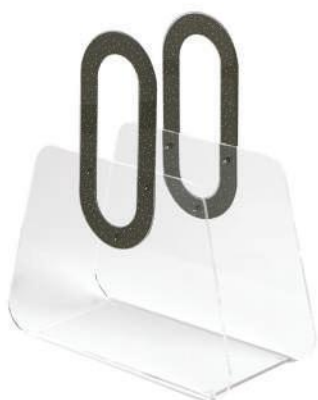



FLEXA WOOD

design by UTE

CL 839 - L 74,5 P 20 cm

Mensola flessibile in legno naturale.
Supporto in metallo verniciato bianco.
(Materiale Plastico Riciclabile)

*Flexible shelf in natural wood.
Coated white support.
(Recyclable Plastic Material)*



FLEXA WHITE

design by UTE

CL 861 - L 74,5 P 20 cm

Mensola flessibile in metacrilato nei colori trasparente, satinato, rosso.
Supporto in metallo verniciato bianco. (Materiale Plastico Riciclabile)

*Flexible methacrylate shelf available in transparent, opaline white and red.
Coated white support. (Recyclable Plastic Material)*



FLEXA

design by UTE

CL 907 - L 74,5 P 20 cm

Mensola flessibile in metacrilato nei colori trasparente, satinato, rosso.
Supporto in metallo verniciato grigio. (Materiale Plastico Riciclabile)

*Flexible methacrylate shelf available in transparent, opaline white or red.
Coated grey support. (Recyclable Plastic Material)*



BIMENSOLA

design by UTE

CL 053 - L 100 P 20 H 16 cm

Mensola in metacrilato disponibile nei colori trasparente, satinato, rosso e nero.
(Materiale Plastico Riciclabile)

*Methacrylate shelf, available in transparent, opaline white, red and black colour.
(Recyclable Plastic Material)*



SNELLA

design by UTE

CL 731 - L 40 P 20 H 20 cm

Mensola in metacrilato satinato con supporti per fissaggio a muro in metallo cromato. (Materiale Plastico Riciclabile)

Opaline white methacrylate shelf. Chromed details.
Wall mounting. (Recyclable Plastic Material)



Esempio // Example



PLANA 15

design by UTE

CL 105 - L 50 P 15 cm

CL 104 - L 75 P 15 cm

CL 103 - L 90 P 15 cm

Mensola in metacrilato disponibile nei colori trasparente, satinato, rosso e nero coprente. (Materiale Plastico Riciclabile)

Methacrylate shelf available in transparent, opaline black, red and opaline white. (Recyclable Plastic Material)



PLANA 22

design by UTE

CL 102 - L 50 P 22 cm

CL 101 - L 75 P 22 cm

CL 100 - L 90 P 22 cm

Mensola in metacrilato disponibile nei colori trasparente, satinato, rosso e nero coprente. (Materiale Plastico Riciclabile)

Methacrylate shelf available in transparent, opaline black, red and opaline white. (Recyclable Plastic Material)



FLOWER

design by UTE

CL 4031 - L 60 P 24 H 24 cm

Mensola in metacrilato trasparente.
(Materiale Plastico Riciclabile)

Transparent methacrylate shelf.
(Recyclable Plastic Material)



CL 4032 - L 60 P 24 H 24 cm

Mensola in metacrilato trasparente con decoro nei colori verde, fucsia, rosso, blu. (Materiale Plastico Riciclabile)

Shelf in transparent methacrylate with texture in green, fuchsia, red, blue.
(Recyclable Plastic Material)



CL 4025 - L 60 P 23 H 25 cm

Mensola in metacrilato trasparente.
(Materiale Plastico Riciclabile)

Transparent methacrylate shelf.
(Recyclable Plastic Material)



CL 4026 - L 60 P 23 H 25 cm

Mensola in metacrilato trasparente con decoro nei colori blu,
fucsia, verde, rosso. (Materiale Plastico Riciclabile)

Transparent methacrylate shelf available in blue, fuchsia, green, red.
(Recyclable Plastic Material)



SILVER

design by UTE

CL 725 - L 2 P 6,5 H 12 cm

Appendiabiti in metacrilato verniciato argento.
(Materiale Plastico Riciclabile)

Clothes hook in silver painted methacrylate.
(Recyclable Plastic Material)



ARGENT

design by UTE

CL 727 - L 2 P 6 H 12 cm

Appendiabiti in metacrilato verniciato argento.
(Materiale Plastico Riciclabile)

Clothes hook in silver painted methacrylate.
(Recyclable Plastic Material)



TRIX

design by UTE

CL 906 - Ø 36 H 4,5 cm

Appendiabiti in metallo verniciato nero. Pomelli in ABS disponibili
nei colori: bianco, nero e rosso. (Materiale Plastico Riciclabile)

*Clothes hanger in black painted metal. Details in ABS available in white,
black and red. Wall mounting.* (Recyclable Plastic Material)



XDUE WOOD

design by UTE

CL 837 - L min. 24 max. 54 P 5 cm

Appendiabiti in alluminio verniciato bianco, particolari in legno naturale, pomelli in ABS verniciato colore bianco.
(Materiale Plastico Riciclabile)

*Clothes hanger in painted aluminium coated white. White coated knobs.
(Recyclable Plastic Material)*



XDUE

design by UTE

CL 749 - L min. 24 max. 54 P 5 cm

Appendiabiti in alluminio, particolari in metacrilato nei colori trasparente, satinato e rosso. (Materiale Plastico Riciclabile)

Clothes hanger in aluminium. Methacrylate hooks, available in transparent, opaline white and red. (Recyclable Plastic Material)



TREPALLE

design by UTE

CL 789 - L 20 P 9 H 14 cm

Appendiabiti a 3 ganci orientabili in metacrilato trasparente con fissaggio a parete in acciaio inox. (Materiale Plastico Riciclabile)

*Three hooks methacrylate coat hanger.
Wall fastening in stainless steel. (Recyclable Plastic Material)*



OBLÒ

design by UTE

CL 747 - D 12 P 5 cm

Appendiabiti in metacrilato nei colori trasparente, satinato, rosso, nero e bianco. (Materiale Plastico Riciclabile)

Clothes hanger in transparent methacrylate, available in transparent, opaline white, black, red and white. (Recyclable Plastic Material)



BUBBLE

design by UTE

CL 4002 - L 52 P 4 H 17 cm

Appendiabiti in metacrilato satinato con decoro nei colori: blu, verde, fucsia, rosso. (Materiale Plastico Riciclabile)

Clothes hanger in opaline white methacrylate with texture in blue, green, fuchsia and red. (Recyclable Plastic Material)



PIO

design by UTE

CL 4000 - L 49 P 4 H 27 cm

Appendiabiti in metacrilato satinato con decoro nei colori blu, verde, fucsia, rosso. (Materiale Plastico Riciclabile)

Clothes hanger in opaline white methacrylate with texture in blue, green, fuchsia and red. (Recyclable Plastic Material)



ALVEO

design by UTE

CL 740 - L 10 P 5,5 H 10 cm

Appendiabiti in metacrilato trasparente con decoro nei colori bianco, verde, rosso, giallo, blu. (Materiale Plastico Riciclabile)

Clothes hanger in transparent methacrylate with white, green, red, yellow, and blue decorative patterns. (Recyclable Plastic Material)



CL 721 - L 10 P 5,5 H 10 cm

Appendiabiti in metacrilato satinato. (Materiale Plastico Riciclabile)

Clothes hanger in opaline white methacrylate. (Recyclable Plastic Material)



BULBO

design by Roberto Giacomucci

CL 739 - L 9 P 5,5 H 9 cm

Appendiabiti in metacrilato trasparente con decoro nei colori: bianco, verde, rosso, giallo, blu. (Materiale Plastico Riciclabile)

Clothes hanger in transparent methacrylate with texture in white, green, red, yellow and blue. (Recyclable Plastic Material)



CL 719 - L 9 P 5,5 H 9 cm

Appendiabiti in metacrilato satinato. (Materiale Plastico Riciclabile)

Clothes hanger in opaline white methacrylate. (Recyclable Plastic Material)



TOAST

design by UTE

CL 902 (con base / ground version) - L 17,5 P 17,5 H 125 cm

Porta CD in metacrilato. Disponibile nei colori satinato e trasparente. Contiene 72 CD.
(Materiale Plastico Riciclabile)

*Methacrylate CDs case. Chromed details. Available in opaline white and transparent. It contains 72 CDs.
(Recyclable Plastic Material)*



Colori_Colours

- 01 Love
- 02 Onde/Waves
- 03 Piramidi/Pyramids
- 04 Fantasia/Fantasy
- 05 Nero/Black
- 10 Bianco/White
- 11 Trasparente/Transparent
- 12 Bianco satinato/Opaline white
- 14 Bianco matt/Matt white • Natural opal
- 15 Bianco perla/Pearl white
- 16 Decoro righe bianco/White stripes decoration
- 20 Verde/Green
- 21 Giallo/Yellow
- 23 Verde Fluorescente/Fluorescent green
- 29 Viola/Violet
- 32 Oro/Gold
- 33 Argento/Silver
- 34 Cromato/Chromed
- 35 Dorato/Golden
- 36 Rame/Copper
- 41 Arancio/Orange
- 43 Arancio Fluorescente/Fluorescent orange
- 48 Rosa/Pink
- 49 Fucsia/Fuchsia
- 51 Rosso/Red
- 53 Nuance Rosso/Nuance Red
- 55 Cromolite
- 57 Oro/Gold
- 58 TexturGold
- 59 Bronzo/Bronze
- 61 Blu/Blue
- 63 Celeste/Light blue
- 64 Celeste opal/Light blue opal
- 67 Tessuto intrecciato
- 70 Frassino/Ash wood
- 71 Noce/Walnut
- Trama nero/Texture black
- Trama rosso/Texture red
- 88 Spectral
- 89 Decoro filii/Thread-like decoation
- 91 Nuance grigio/Nuance gray
- Macchie nero/Black spots
- 94 Grigio matt/Matt gray • Grigio opal/Gray opal
- 95 Bicolor bianco satinato/cromolite
Bicolor opaline white/cromolite
- 96 Quadri grigio/Grey checks
- 97 Bicolor bianco satinato/oro
Bicolor opaline white/gold
- 98 Fume'
- 99 Multicolor/Multicolour

DESIGNERS

STUDIO TECNICO EMPORIUM

WALTER SBICCA

ROMEO GUARICCI

LUCIA PIERINI

NICOLA CERASA

MAMMINI CANDIDO

GAETANO AVITABILE

LORENZO RADAELLI

STUDIO KUBLA

AD WALTER SBICCA

PHOTO ANDREA BELLEZZA - GIULIA LOCCIONI

GRAPHIC DESIGN UFFICIO TECNICO EMPORIUM - GABRIELE PIERINI - ANDREA BELLEZZA

Tutti i prodotti sono **MADE IN ITALY**

All products are **MADE IN ITALY**



EMPORIUM

Plexi srl - C/da Marolino - S.S. Regina Km 6,5 - 62018 Potenza Picena (MC) ITALY

Tel. (+39) 0733 671747 - Fax. (+39) 0733 870081

emporium@emporium.it - www.emporium.it





EMPORIUM

LIGHT BOOK

DESIGNERS



WALTER SBICCA



GABRIELE SAVI



M'ILLUMINO DI EMPORIUM

“Ritrovarsi insieme è un inizio, restare insieme è un progresso, riuscire a lavorare insieme è un successo”. Emporium sceglie la prestigiosa frase di Henry Ford per ribadire l'importanza del gioco di squadra. Una squadra che sposa appieno la filosofia del pensiero positivo. Dal 1997 Emporium reinterpreta il concetto di luce e spazio, attraverso la creazione di oggetti che hanno l'ambizione di suscitare positività, ottimismo e fiducia.



Tutti i materiali plastici utilizzati sono riciclabili.



I'M ENLIGHTED WITH EMPORIUM

“Coming together is the beginning. Keeping together is progress. Working together is success “. Emporium chooses the prestigious quote of Henry Ford to reiterate the importance of teamwork. A team that fully embraces the philosophy of positive thinking. Since 1997 Emporium reinterprets the concept of light and space, through the creation of objects that have the ambition to arouse positivity, optimism and trust.



All plastic materials used are recyclable.

PAOLA

design by Walter Sbicca



PAOLA

design by Walter Sbicca

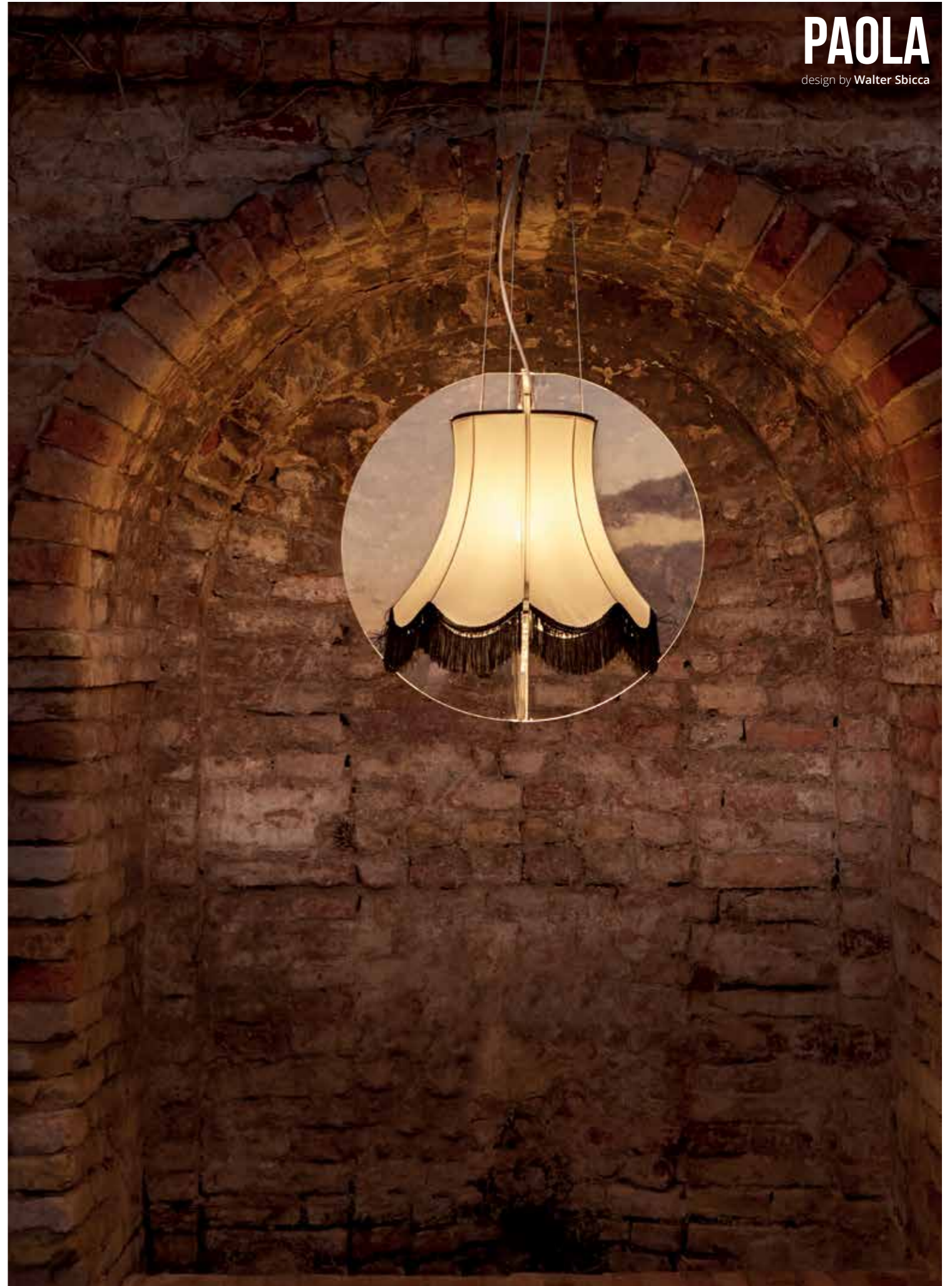

PAOLA

design by Walter Sbicca

CL 1680

Sospensione. Struttura in PMMA trasparente, paralume in tessuto con frange. Paralumi disponibili nei colori: nero, bianco, rosso e grigio. Accessori per fissaggio a soffitto in ottone cromato e cavi in acciaio. (materiali plastici riciclabili)

Suspension lamp. Structure in transparent PMMA, fabric lampshade with fringes. Lampshades available in black, white, red and grey. Accessories for ceiling mounting in chromed brass and steel cables. (recyclable plastics)

05 10 51 94

∅ 50 cm



Attacco E27 Filo L.160 cm.
Lampadine: 1 x 70 W max - E27 HGS

E27 screw. Wire length 160 cm.
Bulbs: 1 x 70 W max - E27 HGS



PAOLA

design by Walter Sbicca

CL 1681

Sospensione. Struttura in PMMA trasparente, paralume in tessuto con frange. Paralumi disponibili nei colori: nero, bianco, rosso e grigio. Accessori per fissaggio a soffitto in ottone cromato e cavi in acciaio. (materiali plastici riciclabili)

Suspension lamp. Structure in transparent PMMA, fabric lampshade with fringes. Lampshades available in black, white, red and grey. Accessories for ceiling mounting in chromed brass and steel cables. (recyclable plastics)

05 10 51 94

∅ 40 cm



Attacco E27 Filo L.160 cm.
Lampadine: 1 x 70 W max - E27 HGS

E27 screw. Wire length 160 cm.
Bulbs: 1 x 70 W max - E27 HGS



PAOLA

design by Walter Sbicca



PAOLA

design by Walter Sbicca

PAOLA

design by Walter Sbicca

CL 1683

Lampada da tavolo, struttura in PMMA trasparente, paralume in tessuto con frange. Paralumi disponibili nei colori: nero, bianco, rosso e grigio.
(materiali plastici riciclabili)

*Floor lamp, transparent PMMA structure, fabric lampshade with fringes. Lampshades available in black, white, red and grey.
(recyclable plastics)*

05 10 51 94

∅ 35 cm



H 50 cm

Attacco E27

Lampadine: 1 x 70 W max - E27 HGS

E27 screw.

Bulbs: 1 x 70 W max - E27 HGS



PAOLA

design by Walter Sbicca



PAOLA

design by Walter Sbicca



PAOLA

design by Walter Sbicca

CL 1684

Abat-jour. Struttura in PMMA trasparente, paralume in tessuto con frange. Paralumi disponibili nei colori : nero, bianco, rosso e grigio. (materiali plastici riciclabili)

Abat-jour . Structure in transparent PMMA, fabric lampshade with fringes. Lampshades available in black, white, red and grey. (recyclable plastics)

05 10 51 94

L 20 cm

Attacco E14
Lampadine: 1 x 30 W max - E14 FBT



H 36 cm

E14 screw.
Bulbs: 1 x 30 W max - E14 FBT



PAOLA

design by Walter Sbicca

PAOLA

design by Walter Sbicca

CL 1688

Lampada da tavolo ricaricabile . Struttura in PMMA trasparente, paralume in tessuto con frange. Paralumi disponibili nei colori: nero, bianco, rosso e grigio. Ricaricabile autonomia fino a max 9 ore. (materiali plastici riciclabili)

Table lamp rechargeable. Structure in transparent PMMA, fabric lampshade with fringes. Lampshades available in black, white, red and grey. Connection Rechargeable autonomy up to max 9 hours. (recyclable plastics)

L 20 cm

Led 4W luce calda 3000k

Led 4W warm light 3000k



05 10 51 94



PAOLA

design by Walter Sbicca





PAOLA

design by Walter Sbicca

CL 1682

Lampada da terra, struttura in PMMA trasparente, paralume in tessuto con frange. Paralumi disponibili nei colori: nero, bianco, rosso e grigio. (materiali plastici riciclabili)

Floor lamp, transparent PMMA structure, fabric lampshade with fringes. Lampshades available in black, white, red and grey. (recyclable plastics)

05 10 51 94

Ø 59 cm

Attacco E27

Lampadine: 1 x 70 W max - E27 HGS

E27 screw.

Bulbs: 1 x 70 W max - E27 HGS



H 177 cm





CL 1687

Lampada da terra. Struttura in legno massello di frassino, paralumi in sandylex con particolari di supporto in PMMA trasparente, accessori di fissaggio in ottone cromato. Paralumi disponibili nelle versioni: bianco /trasparente, bianco / bianco e bianco/ grigio. (materiali plastici riciclabili)

Floor lamp. Structure in solid ash wood, lampshades in sandylex with details in transparent PMMA, fixing accessories in chromed brass. Lampshades available in the following versions: white/transparent, white/white and white/grey. (recyclable plastics)

11 15 92

Ø 43 cm



Attacco E27
Lampadine: 1 x 70 W max - E27 HGS

E27 screw.
Bulbs: 1 x 70 W max - E27 HGS



CL 1686

Lampada da terra. Struttura in legno massello di mogano, paralumi in sandylex con particolari di supporto in PMMA trasparente, accessori di fissaggio in ottone cromato. Paralumi disponibili nelle versioni: bianco /trasparente, bianco / bianco e bianco/ grigio. (materiali plastici riciclabili)

Floor lamp. Structure in solid mahogany wood, lampshades in sandylex with details in transparent PMMA, fixing accessories in chromed brass. Lampshades available in the following versions: white/transparent, white/white and white/grey. (recyclable plastics)

11 15 92

Ø 43 cm



H 175 cm

Attacco E27
Lampadine: 1 x 70 W max - E27 HGS

E27 screw.
Bulbs: 1 x 70 W max - E27 HGS



CL 1685

Lampada da terra. Struttura in legno massello di noce, paralumi in sandylex con particolari di supporto in PMMA trasparente, accessori di fissaggio in ottone cromato. Paralumi disponibili nelle versioni: bianco /trasparente, bianco / bianco e bianco/ grigio. (materiali plastici riciclabili)

Floor lamp. Structure in solid walnut wood, lampshades in sandylex with details in transparent PMMA, fixing accessories in chromed brass. Lampshades available in the following versions: white/transparent, white/white and white/grey. (recyclable plastics)

11 15 92

Ø 43 cm



H 175 cm

Attacco E27
Lampadine: 1 x 70 W max - E27 HGS

E27 screw.
Bulbs: 1 x 70 W max - E27 HGS



Colori_Colours

- 05 Nero/Black
- 10 Bianco/White
- 11 Trasparente/Transparent
- 12 Bianco satinato/Opaline white
- 14 Bianco matt/Matt white • Natural opal
- 15 Bianco perla/Pearl white
- 20 Verde/Green
- 21 Giallo/Yellow
- 29 Viola/Violet
- 32 Oro/Gold
- 33 Argento/Silver
- 34 Cromato/Chromed
- 35 Dorato/Golden
- 36 Rame/Copper
- 41 Arancio/Orange
- 48 Rosa/Pink
- 49 Fucsia/Fuchsia
- 51 Rosso/Red
- 53 Nuance Rosso/Nuance Red
- 55 Cromolite
- 57 Oro/Gold
- 58 TexturGold
- 59 Bronzo/Bronze
- 61 Blu/Blue
- 63 Celeste/Light blue
- 64 Celeste opal/Light blue opal
- 67 Tessuto intrecciato
- 70 Frassino/Ash wood
- 71 Noce/Walnut
- 88 Spectrall
- 89 Decoro fili/Thread-like decoation
- 91 Nuance grigio/Nuance gray
- 92 Bicolor bianco/grigio
Bicolor white/grey
- 94 Grigio matt/Matt gray • Grigio opal/Gray opal
- 95 Bicolor bianco satinato/cromolite
Bicolor opaline white/cromolite
- 97 Bicolor bianco satinato/oro
Bicolor opaline white/gold
- 98 Fume'
- 99 Multicolor/Multicolour

DESIGNERS

WALTER SBICCA
GABRIELE SAVI

AD WALTER SBICCA
PHOTO ANDREA BELLEZZA - WALTER SBICCA
GRAPHIC DESIGN UFFICIO TECNICO EMPORIUM - GABRIELE PIERINI - ANDREA BELLEZZA

Tutti i prodotti sono **MADE IN ITALY**
*All products are **MADE IN ITALY***



EMPORIUM

Emporium srl - C/da Marolino - S.S. Regina Km 6,5 - 62018 Potenza Picena (MC) ITALY
Tel. (+39) 0733 671747 - Fax. (+39) 0733 870081
emporium@emporium.it - www.emporium.it



