

CAMERETTE



DIELLE
GRUPPO DOIMO

DESIGN IN PROGRESS CAMERETTE COLLECTION

- 8 | **C01** XCAB CABINA ARMADIO
XCAB WALK-IN CLOSET
- 34 | **C02** CABINE ARMADIO DI SISTEMA
WALK-IN CLOSETS
- 52 | **C03** SISTEMA MIX
MIX SYSTEM
- 92 | **C04** SISTEMA LIBRERIA PALO ALTO
PALO ALTO BOOKCASE SYSTEM
- 132 | **C05** SISTEMA INTEGRALE MASTER
MASTER SYSTEM
- 152 | **C06** ARMADI AD ANTE BATTENTI + SPACE SAVING
HINGED DOORS WARDROBES + SPACE SAVING
- 186 | **C07** ARMADI AD ANTE SCORREVOLI
SLIDING DOORS WARDROBES

C01 XCAB CABINA ARMADIO / XCAB WALK-IN CLOSET



10



14



22



24



26



30

C02 CABINE ARMADIO DI SISTEMA / WALK-IN CLOSETS



36



42



44

C02 CABINE ARMADIO DI SISTEMA / WALK-IN CLOSETS



48



50

C03 SISTEMA MIX / MIX SYSTEM

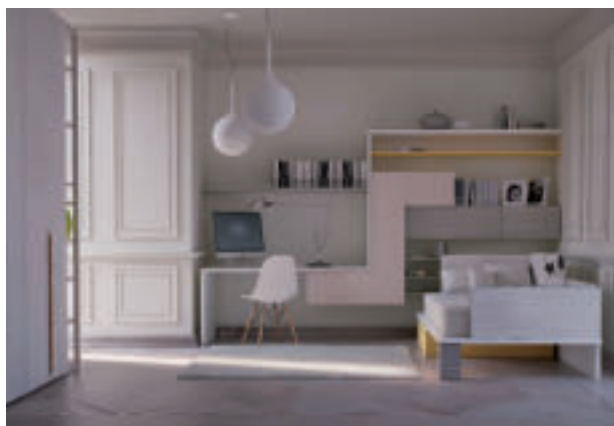

54



58



62



64



66



72

DIELLE
GRUPPO DOIMO

C03 SISTEMA MIX / MIX SYSTEM



76



78



82



88



90

C04 SISTEMA LIBRERIA PALO ALTO / PALO ALTO BOOKCASE SYSTEM



96



102



105

C04 SISTEMA LIBRERIA PALO ALTO / PALO ALTO BOOKCASE SYSTEM



108



112



118



124



126



128

C05 SISTEMA INTEGRALE MASTER / MASTER SYSTEM



134



136



138

DIELLE
GRUPPO DOIMO

C05 SISTEMA INTEGRALE MASTER / MASTER SYSTEM



140



144



146

C06 ARMADI AD ANTE BATTENTI + SPACE SAVING / HINGED DOORS WARDROBES + SPACE SAVING



154



164



166

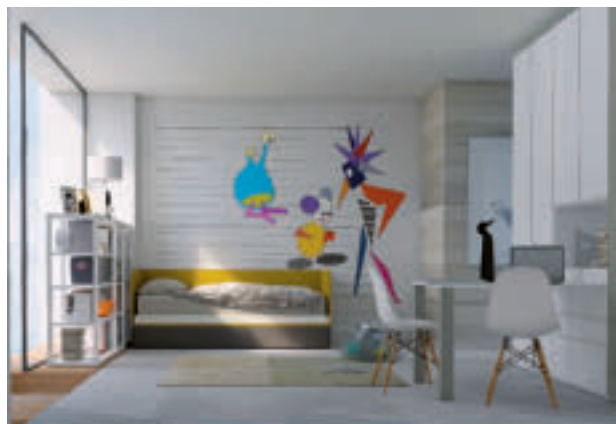

168



172



174

C06 ARMADI AD ANTE BATTENTI + SPACE SAVING / HINGED DOORS WARDROBES + SPACE SAVING

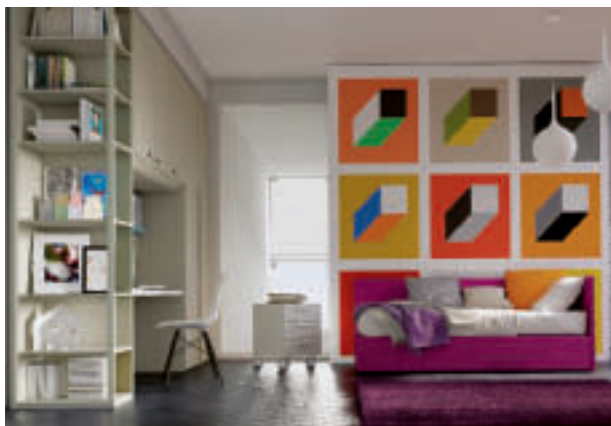

176



178



182

C07 ARMADI AD ANTE SCORREVOLI / SLIDING DOORS WARDROBES

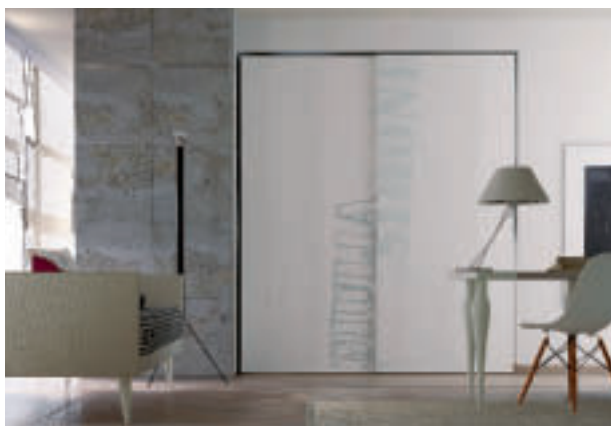

188

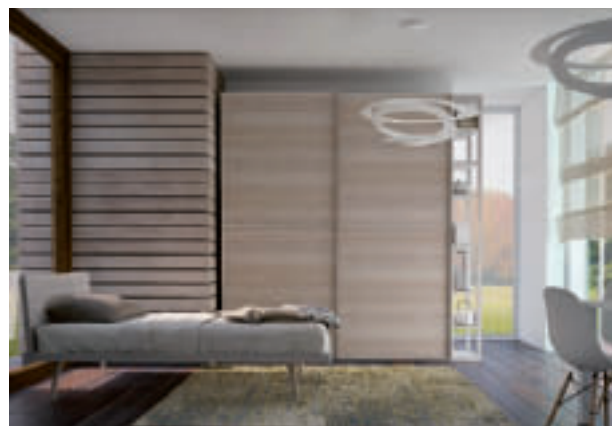

190



192



194



196



202

DIELLE
GRUPPO DOIMO



XCAB CABINE ARMADIO INTEGRATE

C01

ARREDARE CON XCAB

XCAB È LA CABINA ARMADIO CHE OGGI DIELLE RENDE ACCESSIBILE A TUTTI CON UN COSTO PARAGONABILE AI NORMALI ELEMENTI PROFONDITÀ CM 60. • XCAB IS THE WARDROBE CAB WHICH IS MADE AVAILABLE TO EVERYBODY BY DIELLE WITH A PRICE COMPARABLE TO THE NORMAL ELEMENTS 60 CM. DEEP.

ACCESSIBILITÀ TOTALE

LA PROFONDITÀ 95 DEGLI ELEMENTI componibili consente una accessibilità totale per una funzionalità superiore. • THE DEPTH 95 OF THE MODULAR ELEMENTS ALLOWS A TOTAL ACCESSIBILITY FOR A SUPERIOR FUNCTIONALITY.

VERSATILMENTE componibile

L'IMPIEGO DELLA CABINA ARMADIO È VERSATILE E FUNZIONALE CREANDO composizioni angolari, ma anche lineari a parete. • THE USE OF THE WARDROBE CAB IS VERSATILE AND FUNCTIONAL CREATING CORNER COMPOSITIONS BUT ALSO LINEAR ONES AGAINST THE WALL.

XCAB: INTEGRATED WARDROBE CABS





601



LA CABINA ARMADIO MODULARE

XCAB CABINA ARMADIO | XCAB WALK-IN CLOSET



THE MODULAR WARDROBE CAB

È PENSANDO AI RAGAZZI DI OGGI E AL LORO MONDO CHE DIELE HA SVILUPPATO UN'ORIGINALE IDEA DI CAMERETTA: IL SISTEMA CABINA XCAB, IN GRADO DI RACCHIUDERE E ORGANIZZARE ATTORNO A SÈ TUTTE LE ATTIVITÀ DEI RAGAZZI IN UN'ISOLA COMPATTA E FUNZIONALE, SODDISFACENDO AL CONTEMPO LE ESIGENZE DI SPAZIO DELL'ABITARE CONTEMPORANEO.... E DELLE MAMME • DIELE HAS CONCEIVED AND DEVELOPED AN ORIGINAL CHILDREN'S ROOM IDEA: THE XCAB WALK-IN CLOSET SYSTEM ABLE TO ENCLOSE AND ORGANISE AROUND IT ALL THE CHILDREN'S ACTIVITIES IN A COMPACT AND FUNCTIONAL ISLAND, WHILE AT THE SAME TIME CATERING FOR THE NEED FOR SPACE OF CONTEMPO-RARY LIVING...AND OF MOTHERS.

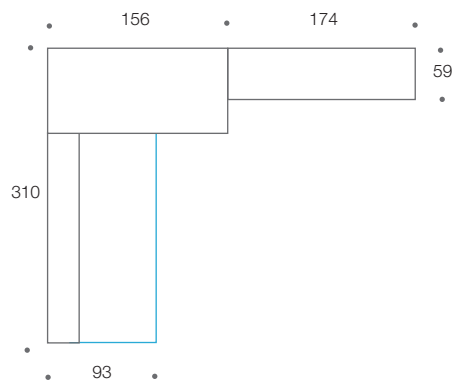

FINITURE - FINISHES (MELAMMINICI / LACCATI)
OLMO PERLA, ROSA, CORDA2.

STILE PERSONALE

GHOST: LO SCRITTOIO A SCOMPARSA

LO SCRITTOIO A SCOMPARSA GHOST ESTRAIBILE PRESENTA UN PIANO STUDIO DI TUTTO RISPETTO CON LE DIMENSIONI GIUSTE PER TUTTE LE ATTIVITÀ DI STUDIO • THE GHOST HIDING EXTRACTABLE DESK PRESENTS A RESPECTING STUDY TOP WITH THE RIGHT DIMENSIONS FOR ALL THE STUDY ACTIVITIES.

IL TERMINALE LIBRERIA PALO ALTO

PALO ALTO CONSENTE LA FORMAZIONE DI TERMINALI A GIORNO, PERSONALIZZABILI CON TEXTURE COLORATE O BIANCONERO • PALO ALTO ALLOWS TO CREATE OPEN ENDING BOOKCASES CUSTOMIZABLE WITH COLOURED OR BLACK-WHITE TEXTURE.

PERSONAL STYLE



LO STICKER DECORATIVO

PERSONALIZZARE CON LO STICKER SCEGLIENDO TRA UNA VASTA GAMMA DI SOGGETTI LUDICI E SIMPATICI O SEMPLICEMENTE COL PROPRIO NOME • CUSTOMIZE WITH THE STICKER CHOOSING AMONG A WIDE RANGE OF LUDIC AND PLEASANT SUBJECTS OR SIMPLY USING ONE'S OWN NAME.

CREA IL TUO APPENDIABITO

UTILIZZANDO COME SFONDO LA CARTA PARATI SI PUÒ, PER ESEMPIO CREARE UN DIVERTENTE "APPENDITUTTO" INTEGRATO AL SOGGETTO • USING THE WALLPAPER AS A BACKGROUND IT'S POSSIBLE FOR EXAMPLE CREATE A FUNNY "HANG ALL" INTEGRATED TO THE SUBJECT.







STILE PERSONALE E VERSATILITÀ

XCAB CABINA ARMADIO

XCAB WALK-IN CLOSET



PERSONAL STYLE AND VERSATILITY

CABINA ARMADIO, AREA RIPOSO-SOCIALIZAZIONE, ZONA STUDIO CON LIBRERIA BASSA E GRANDE PIANO LAVORO ACCOSTATO • WARDROBE CAB, RESTING-SOCIALIZING AREA, STUDY ZONE WITH LOW BOOKCASE AND BESIDE PLACED BIG WORKTOP.

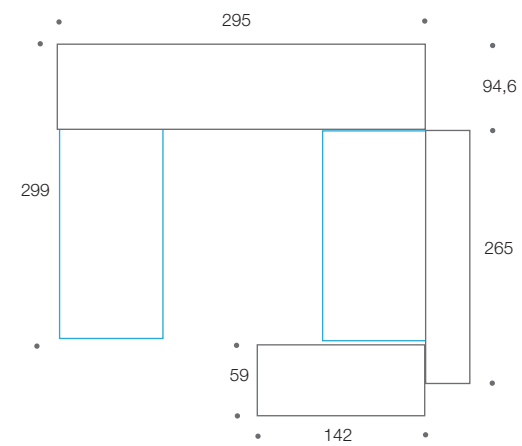

FINITURE - FINISHES (MELAMMINICI / LACCATI)
 BIANCO, GRIGIO CHIARO, CANAPA, PETROLIO2, ROSA, CRETA.
 TEXTURE PUNTO,.



XCAB: LA MODULARITÀ

LA CABINA ARMADIO componibile

LA COMPATTEZZA, LA MODULARITÀ E LA PERFETTA INTEGRAZIONE DI XCAB CON L'INTERO SISTEMA DIELE CONSENTONO DI OTTENERE SOLUZIONI COMPOSITIVE DIVERSIFICATE E COMPLETAMENTE PERSONALIZZABILI NELLA CONFIGURAZIONE DEI SINGOLI ELEMENTI. UN PROGETTO CALIBRATO, A MISURA DEI DESIDERI. • XCAB COMPACT AND MODULAR DESIGN AND ITS PERFECT INTEGRATION WITH THE WHOLE DIELE SYSTEM ALLOWS CUSTOMERS TO ACHIEVE DIVERSIFIED MODULAR SOLUTIONS, AS WELL AS TO FULLY PERSONALISE THE SINGLE ITEMS. A CALIBRATED, CUSTOMER NEEDS FOCUSED PROJECT.

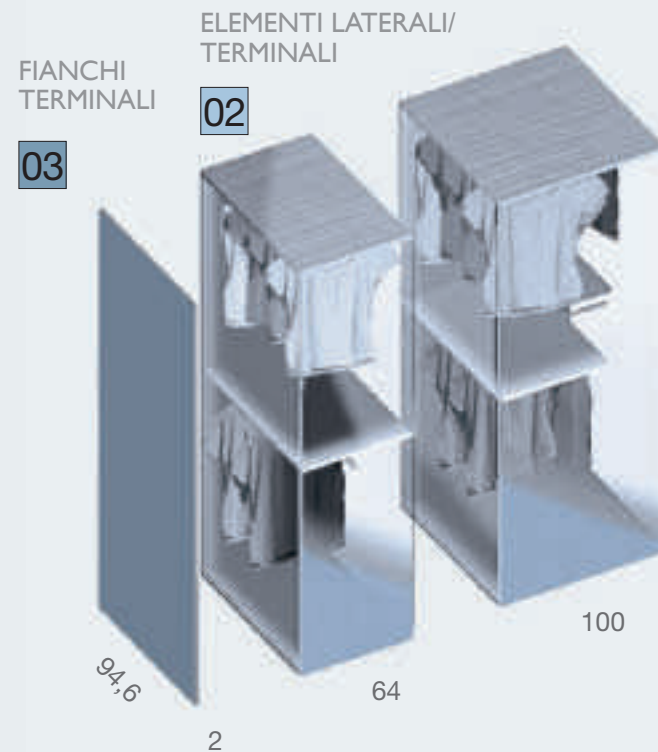

ELEMENTI CENTRALI

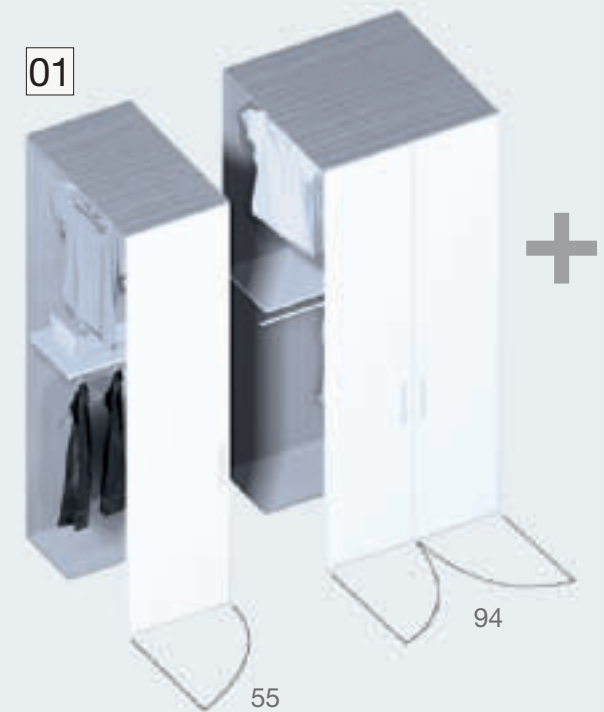

FIANCHI
TERMINALI

03

ELEMENTI LATERALI/
TERMINALI

02

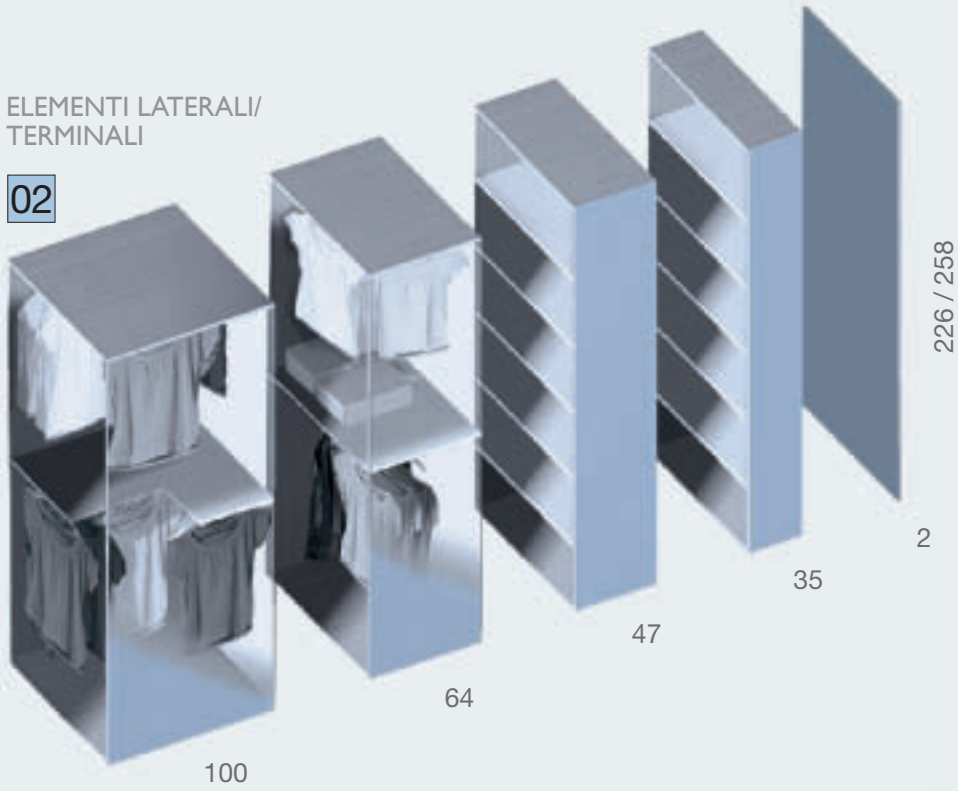

01

ELEMENTI CENTRALI

ELEMENTI PRINCIPALI DI ACCESSO
AD UN'ANTA BATTENTE DX/SX,
O A DUE ANTE BATTENTI

CENTRAL ITEMS

MAIN ACCESS ITEMS WITH A LH/RH
SINGLE SWING DOOR, OR A DOUBLE
SWING DOOR

02

ELEMENTI LATERALI/ TERMINALI

ELEMENTI LATERALI DI CONTENIMENTO
DX/SX, O ELEMENTI TERMINALI
A GIORNO DX/SX, A LARGHEZZE
DIFFERENZIATE

SIDE/END ITEMS

LH/RH STORAGE ITEMS, OR LH/RH,
MULTI-WIDTH DAYTIME USE END ITEMS

03

FIANCHI TERMINALI

PANNELLI DI CHIUSURA CABINA XCAB

END SIDE PANELS

XCAB WALK-IN CLOSET CLOSING PANELS

ESEMPI ACCOSTAMENTO

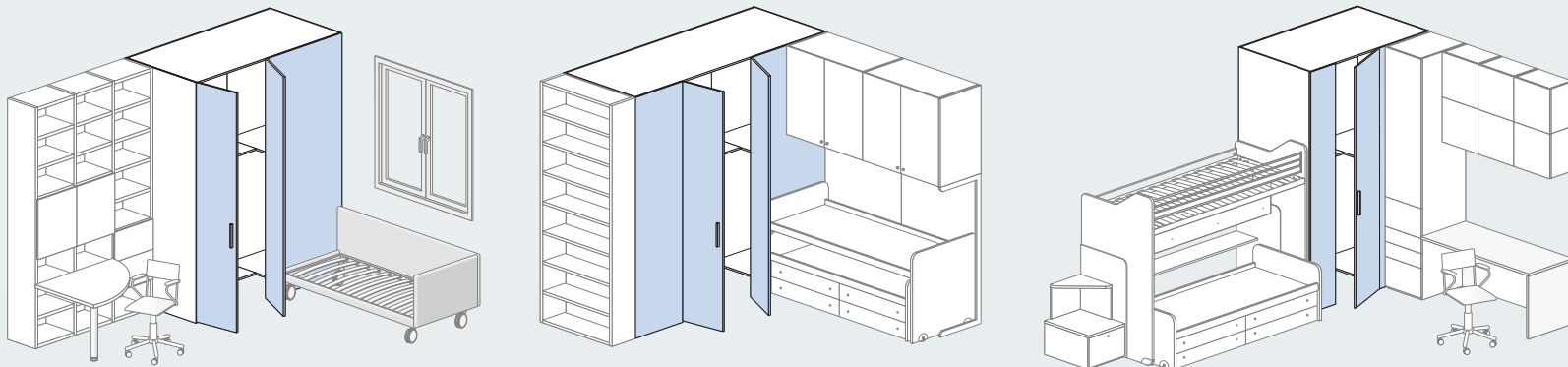

XCAB: CONFIGURAZIONI INTERNE

GLI INTERNI DI XCAB SONO PROGETTATI PER ESSERE UNA VERA E PROPRIA CABINA ARMADIO. UN GRANDE SPAZIO PUÒ ESSERE ALLESTITO A PIACERE CON RIPIANI, CASSETTIERE, APPENDIABITO, SPECCHI E GANCI APPENDITUTTO. LA CABINA ARMADIO DIVENTA PER TUTTI! • THE INSIDE AREAS OF THE XCAB ARE DESIGNED TO CREATE A REAL WALK-IN CLOSET. A LARGE AREA CAN BE SET UP AT WILL WITH SHELVES, DRAWERS, CLOTHES HANGERS, MIRRORS AND CLOTHES HANGING HOOKS. A WALK-IN CLOSET FOR EVERYONE!

1



2



3



4



5



TEXTURE E CARTA PARATI: POIS

TEXTURE AND WALLPAPERS: POIS



RACCORDARE DUE LETTI ALLA CABINA

X CAB CABINA ARMADIO CONSENTE DI RACCORDARE DUE ZONE FUNZIONALI. IN QUESTO CASO DUE LETTI SONO ACCOSTATI AGLI ELEMENTI A CONTENERE • X CAB WARDROBE ALLOWS TO CONNECT TWO FUNCTIONAL ZONES. IN THIS CASE TWO BEDS ARE PLACED BESIDE THE CONTAINMENT ELEMENTS.

AREA LETTI CON ELEMENTI ESSENZIALI

POCHI ESSENZIALI ELEMENTI PENSILI ARREDANO LA PARETE CREANDO UNA SITUAZIONE DI SERVIZIO AI LETTI O ALL'AREA STUDIO E GIOCO • FEW ESSENTIAL WALL CABINETS FURNISH THE WALL CREATING A SERVICE SITUATION FOR THE BEDS OR THE STUDYING AND PLAYING AREA.

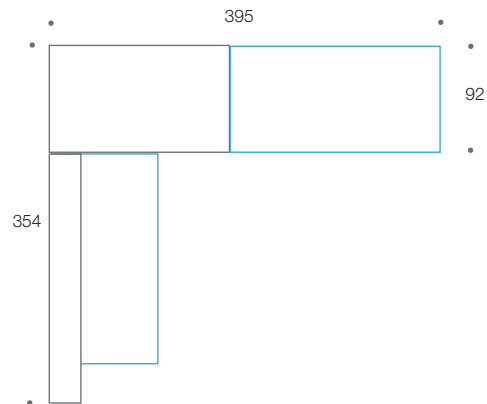

FINITURE - FINISHES (MELAMMINICI / LACCATI)
 CORDA2, BIANCO, ROSA, ORIENTE, PRUSSIA, TEXTURE PUNTO.





603

TEXTURE E CARTA PARATI: ARLECCHINO

TEXTURE AND WALLPAPER: ARLECCHINO



UN'ALLEGRA CARTA PARATI

CREARE UN AMBIENTE "FRESCO E DIVERTENTE" È UN GIOCO DA RAGAZZI UTILIZZANDO LE ESCLUSIVE CARTE PARATI DIELLE DAI CROMATISMI VIVACI E PERSONALIZZATI • CREATING A "FRESH AND FUNNY" AMBIANCE IS A CHILD'S PLAY, USING THE EXCLUSIVE DIELLE WALLPAPERS WITH BRILLIANT AND CUSTOMIZED.

INTEGRAZIONE TRA CARTE PARATI E FINITURE

LE RAFFINATE LACCATURE DI SISTEMA DIALOGANO CON LE CARTE PARATI CREANDO UN HABITAT STUDIATO E PERSONALIZZATO • THE REFINED SYSTEM PAINTINGS DIALOG WITH THE WALLPAPERS CREATING A STUDIED AND CUSTOMIZED HABITAT.

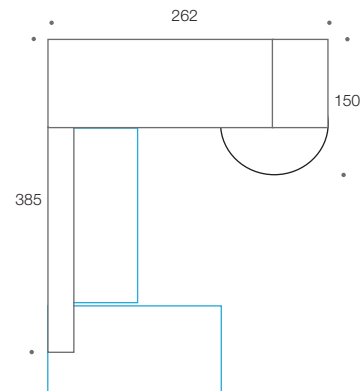

FINITURE - FINISHES (MELAMMINICI / LACCATI)
 OLMO PERLA, BIANCO, MANDARINO, ALABASTRO, TURCHESE,
 PETROLIO2.TEXTURE ARLECCHINO.

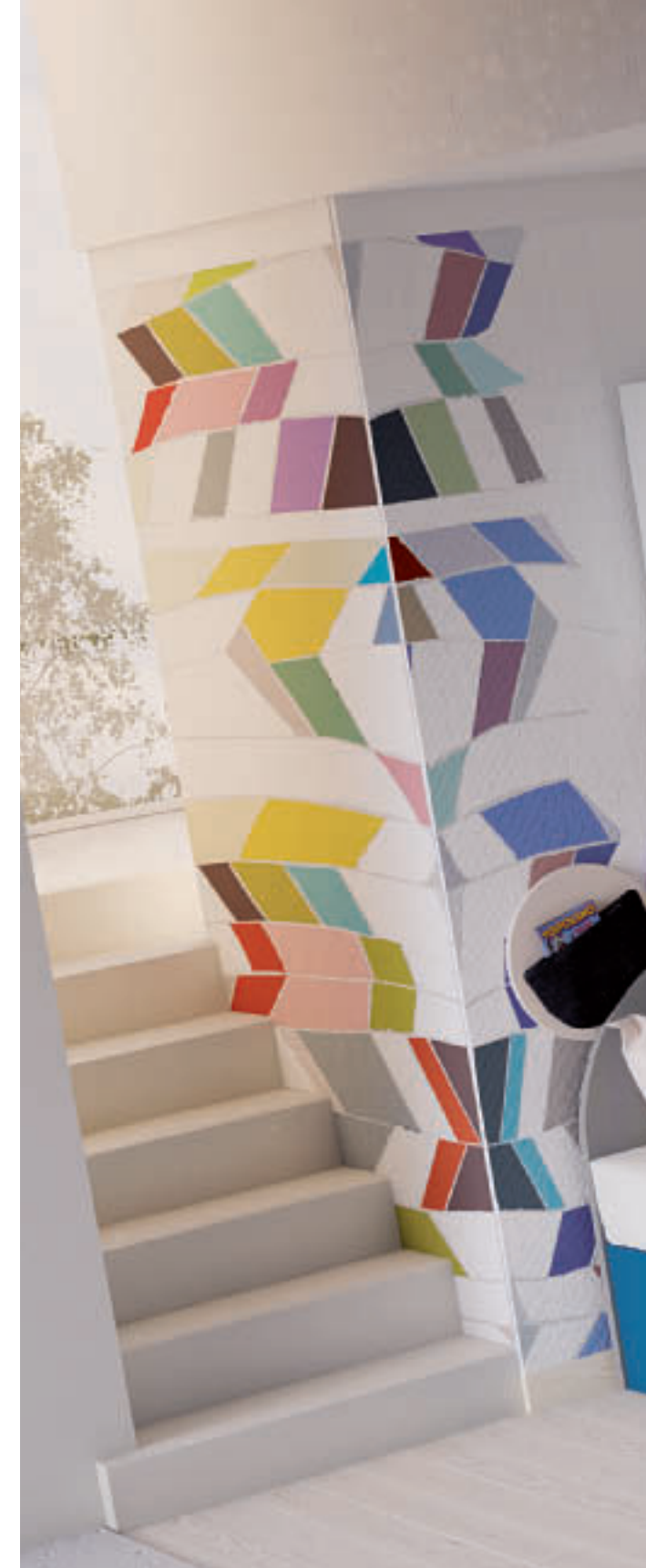



604

TEXTURE E CARTA PARATI: TRATTO

TEXTURE AND WALLPAPERS: TRATTO



SISTEMI D'ARREDO INTEGRALI

LA PERFETTA INTEGRAZIONE DEI SISTEMI DIELLE SPAZIO RAGAZZI CONSENTE DI RACCORDARE L'AREA STUDIO CON LA ZONA RIPOSO CONVERSAZIONE • THE PERFECT INTEGRATION OF THE DIELLE SPAZIO RAGAZZI SYSTEMS ALLOWS TO CONNECT THE STUDY AREA WITH THE RESTING CONVERSATION ZONE.

CABINA CON TERMINALE PALO ALTO

LA NUOVA LIBRERIA PALO ALTO È SOLIDA, MA AL CONTEMPO VISIVAMENTE "LEGGERA" GRAZIE ALL'ARMONIA DEI "PIENI" E DEI "VUOTI" • THE NEW BOOKCASE "PALO ALTO" IS STRONG AND IN THE MEAN-TIME VISUALLY "LIGHT" THANKS TO THE HARMONY OF THE "FULLS" AND THE "EMPTIES".

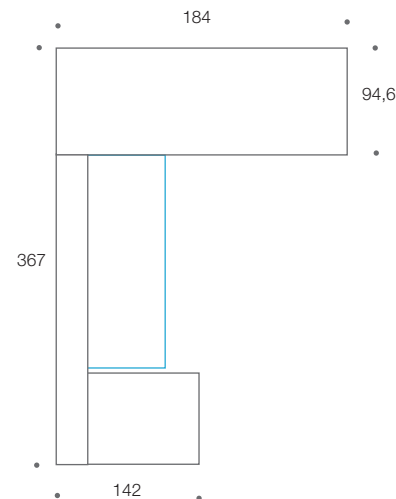

FINITURE - FINISHES (MELAMMINICI / LACCATI)
ROSA, CORDA2, CRETA, BIANCO. TEXTURE TRATTO.





605

IL DESIGN DELLE SUPERFICI

GRAPHIC DESIGN

DIELLE PRESENTA LE GRAFICHE *ARLECCHINO*, *POIS*, *TRATTO* E *CARBONCINO*: UN DESIGN ESCLUSIVO, CHE OFFRE LA POSSIBILITÀ DI PERSONALIZZARE IN MODO FACILE E CREATIVO SIA LE ANTE E LE FACCIATE CHE LE PARETI. UN'IDEA IN PIÙ PER REGALARE ALLA ZONA NOTTE UNO STILE UNICO, CONTEMPORANEO E PERSONALE •
DIELLE PRESENTS THE GRAPHICS *ARLECCHINO*, *POIS*, *TRATTO* AND *CARBONCINO*: AN EXCLUSIVE DESIGN WHICH GIVES THE CHANCE TO EASILY AND CREATIVELY CUSTOMIZE BOTH THE FRONTS AND THE WALLS. AN EXTRA IDEA GIVING TO THE NIGHT ZONE A UNIQUE, CONTEMPORARY AND PERSONAL STYLE.





606





CABINA XCAB E LIBRERIA

XCAB CABINA ARMADIO | XCAB WALK-IN CLOSET



XCAB WALK-IN CLOSET AND BOOKCASE

UN GRANDE SPAZIO A CONTENERE

È POSSIBILE REALIZZARE UNA PRATICA E RAPPRESENTATIVA CABINA ARMADIO INTEGRANDO GLI ELEMENTI componibili DEI SISTEMI LIBRERIA E XCAB CHE GARANTISCONO MODULARITÀ E MASSIMO SFRUTTAMENTO DELLO SPAZIO • IT IS POSSIBLE TO MAKE A PRACTICAL AND REPRESENTATIVE WARDROBE CAB INTEGRATING THE MODULAR ELEMENTS OF THE BOOKCASE AND XCAB SYSTEMS OFFERING MODULARITY AND BEST USE OF THE SPACE.

STILE ROMANTICO

DECLINATI AL FEMMINILE, IL LETTO E LO SCRITTOIO DALLE FORME ERGONOMICHE DANNO UN TOCCO DI CREATIVITÀ ALLO SPAZIO RAGAZZI • ORIENTED TO THE WOMEN'S LIFE, THE ROMANTIC BED AND THE ERGONOMIC SHAPES DESK GIVE A CREATIVE TOUCH TO THE CHILDREN'S SPACE.

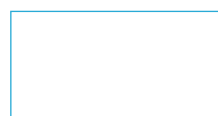
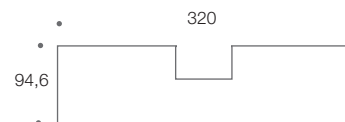

FINITURE - FINISHES (MELAMMINICI / LACCATI)
OLMO PERLA, OLMO NATURALE, ORIENTE. CANARINO, BIANCO, PINK.







LE CABINE ARMADIO DI SISTEMA EMILY, SARA & GIULIA

C02

CABINA ARMADIO EMILY

IDEALE PER COMPOSIZIONI ANGOLARI A DUE ANTE, LA CABINA ARMADIO EMILY SI RACCORDA DA UN LATO CON LA PROFONDITÀ CM 57 • IDEAL FOR CORNER COMPOSITIONS WITH DOUBLE DOOR, THE EMILY WARDROBE CAB CONNECTS ON ONE SIDE THE 57 CM. DEPTH.

CABINA ARMADIO SARA

LA CABINA ANGOLARE SARA A DUE ANTE, SI RACCORDA DA UN LATO CON LA PROFONDITÀ DI CM 40 • THE SARA CORNER CAB WITH DOUBLE DOOR CONNECTS ON ONE SIDE THE 40 CM. DEPTH.

CABINA ARMADIO GIULIA

GIULIA È LA CABINA ARMADIO ANGOLARE CON UNA SOLA ANTA. SI RACCORDA DA UN LATO CON LA PROFONDITÀ CM 57 • GIULIA IS THE CORNER WARDROBE CAB WITH SINGLE DOOR. IT CONNECTS ON ONE SIDE THE 57 CM. DEPTH.

THE SYSTEM WARDROBE CABS: EMILY, SARA & GIULIA





THE CAB WITH CORNER CONTINUITY

LE CABINE ANGOLARI HANNO UNA MODULARITÀ ESTESA PER UN PROGETTO MIRATO DELL'AREA RAGAZZI. SONO STUDIATE PER CONFIGURARSI CON TUTTI GLI ELEMENTI E I SISTEMI componibili DIELLE CON LE PROFONDITÀ IDEALI PER ACCOSTARE LETTI, SOPPALCHI E CASTELLI, AREE STUDIO E LIBRERIE. • CORNER CABINS HAVE A WIDE MODULARITY FOR AN AIMED PROJECT OF CHILDREN AREA. THEY ARE STUDIED TO BE CONFIGURED WITH ALL DIELLE ELEMENTS AND MODULAR SYSTEMS WITH IDEAL DEPTHS TO JUXTAPOSE BEDS, LOFT AND BUNK BEDS, STUDY AREAS AND BOOKCASES.

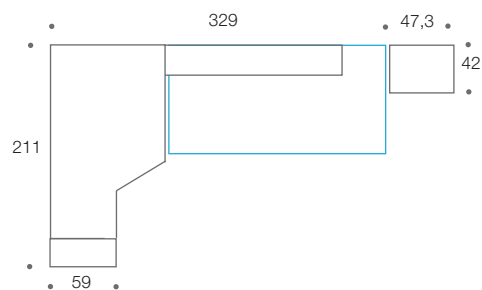

FINITURE - FINISHES (MELAMMINICI / LACCATI)
 BIANCO, MAGNOLIA, GIRASOLE, NUVOLA, ROSA, ORIENTE.

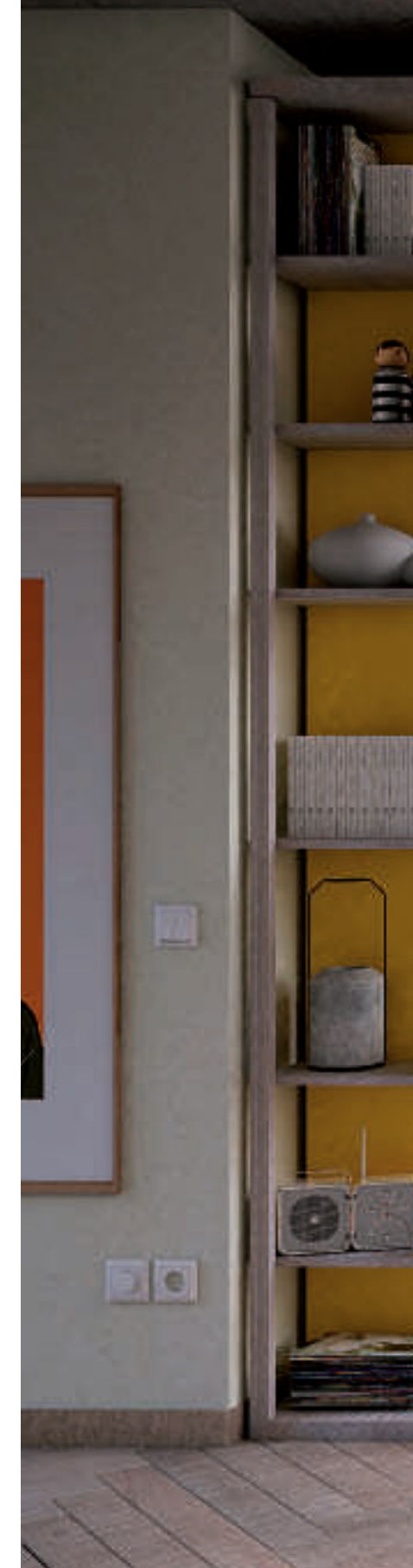



607

CONTENUTI DECORATIVI

LA CARTA PARATI

TRA I CONTENUTI DECORATIVI TROVIAMO LE CARTE PARATI PROPOSTE CON ATTUALISSIMI MOTIVI E TONALITÀ PER PERSONALIZZARE L'HABITAT • AMONG THE ORNAMENTAL CONTENTS THE WALLPAPERS ARE AVAILABLE IN CURRENT MOTIVES AND SHADES TO CUSTOMIZE THE HABITAT

LO STICKER

LO STICKER È UN ALTRO ELEMENTO DISTINTIVO E DI PERSONALIZZAZIONE DELL'AREA RAGAZZI • THE STICKERS ARE ANOTHER DISTINCTIVE ELEMENT FOR THE CUSTOMIZATION OF THE CHILDREN'S AREA.



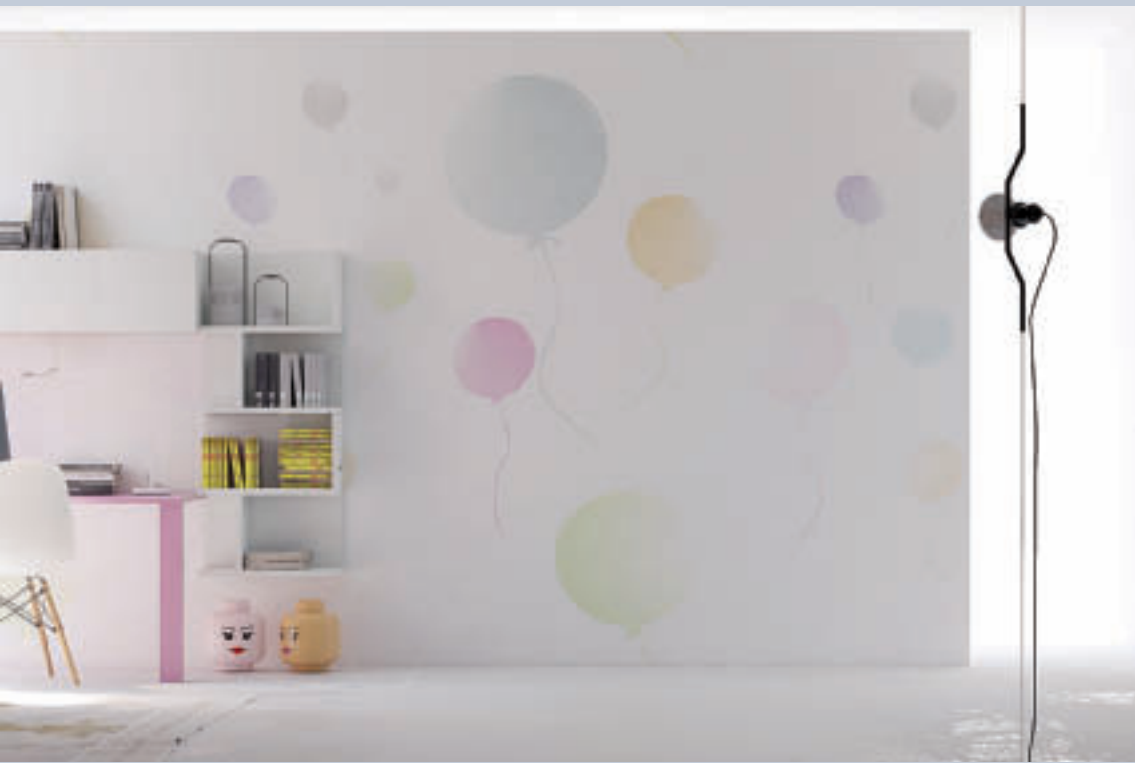

ATTREZZATURE INTERNE

GLI ACCESSORI INTERNI

INTERNAL ACCESSORIES

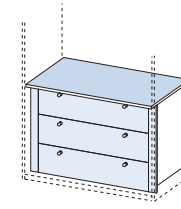

CASSETTIERA INTERNA 3 CASSETTI.
• INTERNAL 3 DRAWERS CHEST.

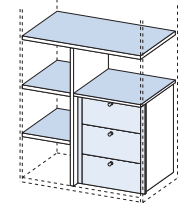

DIVISORIO INTERNO CON CASSETTIERA E 3 RIPIANI.
• INTERNAL PARTITION WITH CHEST OF DRAWER AND 3 SHELVES.

LE CONFIGURAZIONI INTERNE

INTERNAL CONFIGURATIONS

ESEMPI DI UTILIZZO E SOLUZIONI DI ATTREZZATURE INTERNE PER CABINE. • EXAMPLES OF USE AND INTERIOR EQUIPMENT SOLUTIONS FOR CLOSETS.



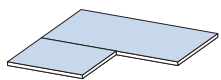

RIPIANI INTERNI SPESSORE 2,5 CM. • INTERNAL SHELVES THICKNESS 2,5 CM.

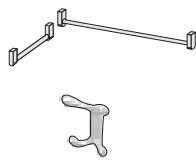

APPENDIABITI. • HANGER.



SPECCHIO INTERNO PER ARMADIO. • INTERNAL MIRROR FOR WARDROBE.

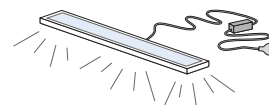

LAMPADA LED CON SENSORE DI PRESENZA. • LED LAMP WITH PRESENCE DETECTOR.

2

3

4



609



2 SQM OF ADDITIONAL SPACE



CABINA ANGOLARE PROFONDITÀ CM 120

LA GRANDE CABINA ANGOLARE ACCOSTA DA UN LATO LA ZONA RIPOSO E DALL'ALTRA PROSEGUE CON UN ELEMENTO ARMADIO E UN TERMINALE LIBRERIA. • THE BIG CORNER CAB FOLLOWS ON ONE SIDE WITH THE RESTING ZONE AND ON THE OTHER SIDE WITH A WARDROBE AND AN ENDING BOOKCASE.

ARKIMEDE DUETTO

ARKIMEDE È UN LETTO SORPRENDENTE CHE RENDE DISPONIBILE UN SECONDO LETTO SCORREVOLE DOTATO DI CASSETTONI. • ARKIMEDE IS AN AMAZING BED ALSO AVAILABLE WITH A SECOND EXTRACTABLE BED EQUIPPED WITH BIG DRAWERS.

2 MQ DI SPAZIO IN PIÙ

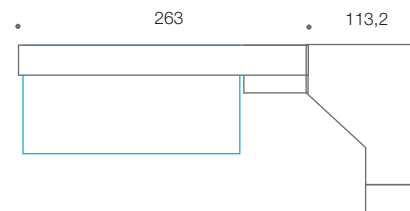

FINITURE - FINISHES (MELAMMINICI / LACCATI)
 OLMO PERLA, OLMO NATURALE, BIANCO, GRIGIO SCURO,
 GRIGIO CHIARO, POLVERE, NUVOLA, ALABASTRO, CORDAZ,
 TEXTURE CARBONCINO.

610





THE CORNER WARDROBE

L'ARMADIO ANGOLARE



L'ARMADIO ANGOLARE
CON LE CABINE ANGOLARI SONO POSSIBILI DELLE COMPOSIZIONI
ARMADIO ANGOLARE A CUI SI ACCOSTANO ZONE STUDIO O
RIPOSO • WITH THE CORNER CABS MANY CORNER COMPOSITIONS
ARE AVAILABLE WITH STUDYING OR RESTING ZONES CONNECTED.

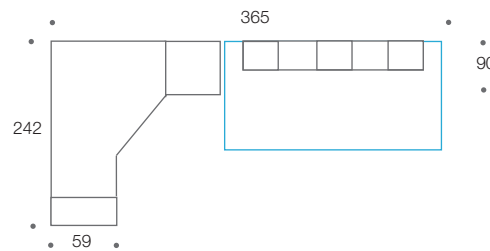

FINITURE - FINISHES (MELAMMINICI / LACCATI)
BIANCO, ROSA, ORIENTE, CICLAMINO, FUCSIA, ALABASTRO, NUVOLA, AVIO.

SISTEMA CABINE ANGOLARI: MODULARITÀ

EMILY profondità cm 57 CABINA A 2 ANTE

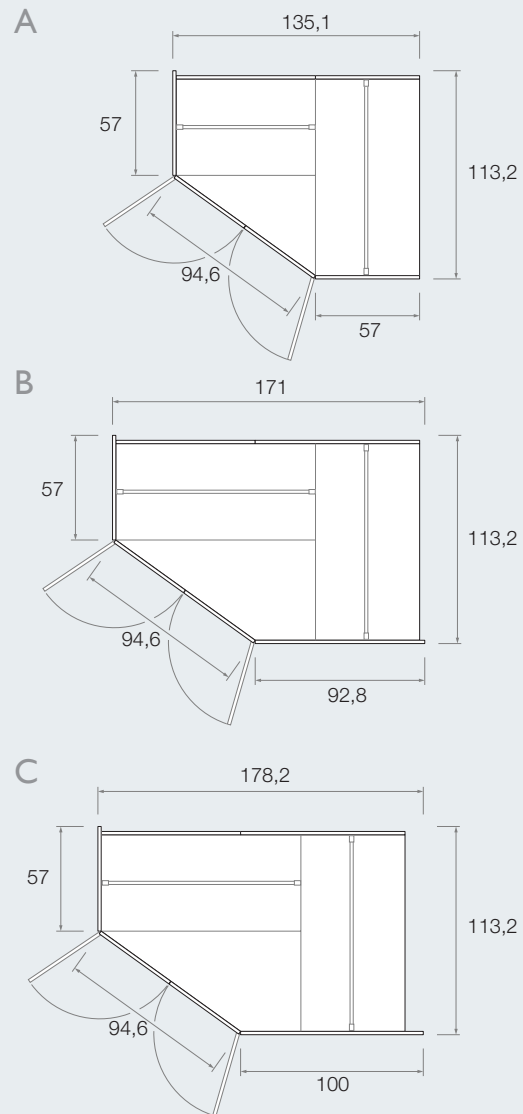

2 DOORS CORNER CABIN

SARA profondità cm 40 CABINA A 2 ANTE CON LATO DA 40 CM.

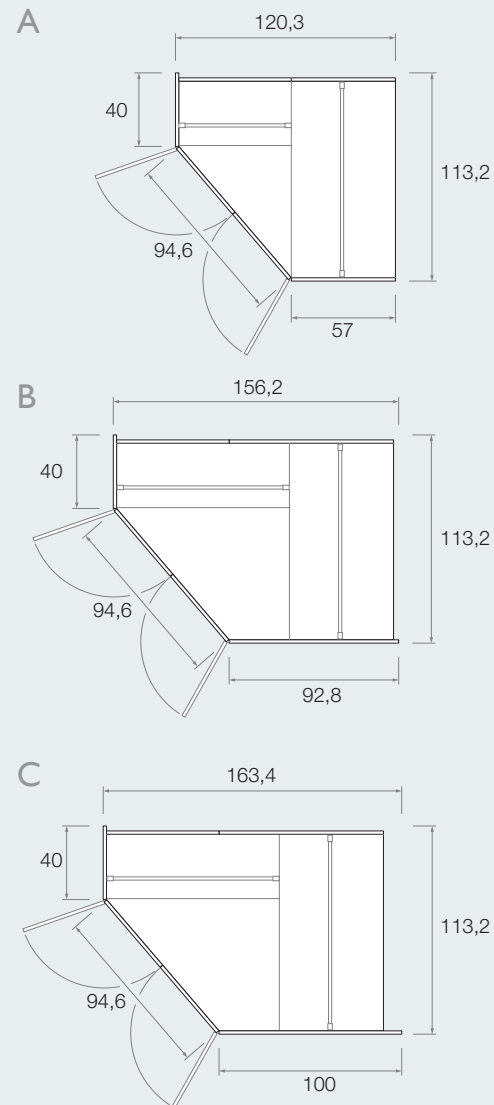

2 DOORS CORNER CABIN
WITH FIXED 40 CM. SIDE



GIULIA CABINA A UN'ANTA

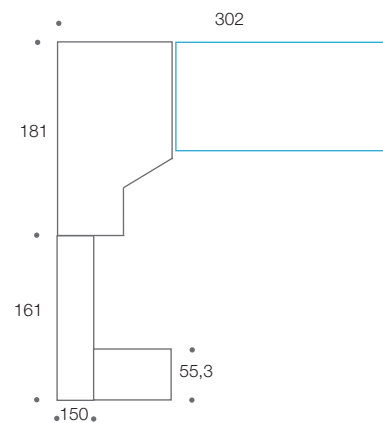
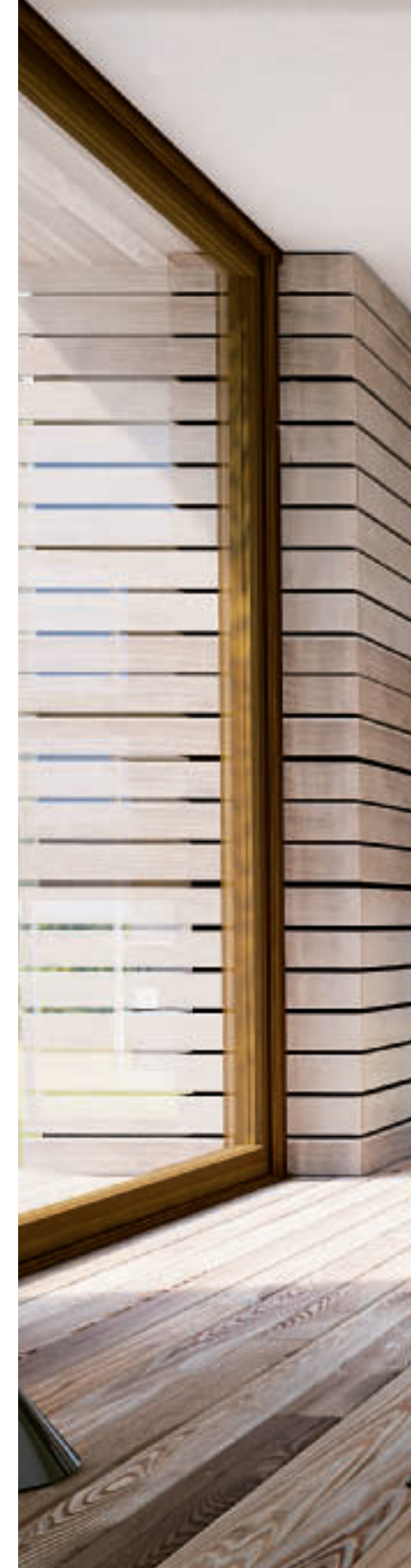
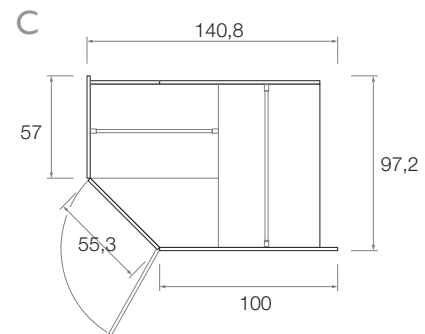
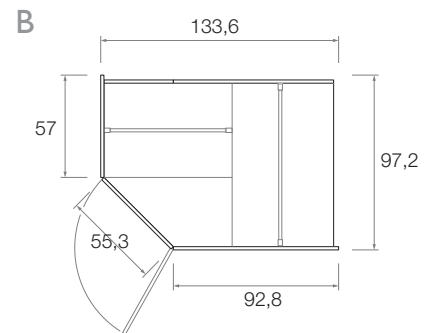
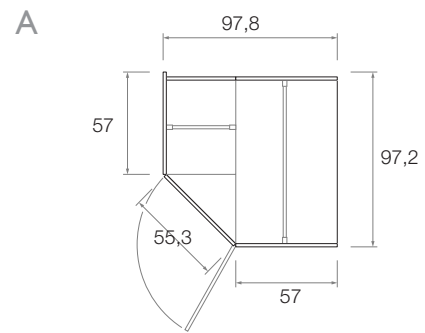

I DOOR CORNER CABIN

FINITURE - FINISHES (MELAMMINICI / LACCATI)
OLMO NATURALE, CORDAZ, PRUSSIA.



611

LA ZONA STUDIO



RACCORDARE LA ZONA RIPOSO CON L'AREA STUDIO

LA PERFETTA INTEGRAZIONE DEI SISTEMI DIELLE SPAZIO RAGAZZI CONSENTE DI RACCORDARE L'AREA STUDIO CON LA ZONA RIPOSO-CONVERSAZIONE • THE PERFECT INTEGRATION AMONG THE DIELLE SPAZIO RAGAZZI SYSTEMS ALLOWS TO CONNECT THE STUDYING AREA WITH THE REST-CONVERSATION AREA.

AREA STUDIO CON LIBRERIA PALO ALTO

LA NUOVA LIBRERIA PALO ALTO È SOLIDA, MA AL CONTEMPO VISIVAMENTE "LEGGERA" GRAZIE ALL'ARMONIA DEI "PIENI" E DEI "VUOTI" • THE NEW BOOKCASE "PALO ALTO" IS STRONG AND IN THE MEANTIME VISUALLY "LIGHT" THANKS TO THE HARMONY OF THE "FULLS" AND THE "EMPTIES".

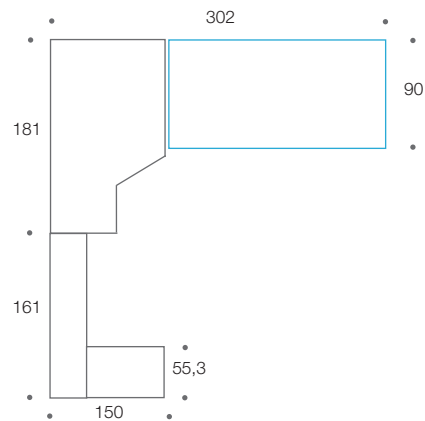

FINITURE - FINISHES (MELAMMINICI / LACCATI)
CORDA2, PRUSSIA, CANARINO.

THE STUDY ZONE





612



MIX L'INSIEME DI PIU SISTEMI

C03

L'INTEGRAZIONE TRA SISTEMI

LA PERFETTA INTEGRAZIONE TRA I SISTEMI DIELE PERMETTE UNA NUOVA RAGIONATA PROGETTUALITÀ COMPOSITIVA. MIX COMBINA I PENSILI GAME GIOCANDO SULLE PROFONDITÀ 3D DEI SUOI CONTENITORI • A REASONED SYSTEM INTEGRATION PROPOSAL - THE PERFECT INTEGRATION OF DIELE SYSTEMS MAKES POSSIBLE NEW AND REASONED CONFIGURATION PLANNING.

SISTEMA LIBRERIA SNAKE E LEAF

I PENSILI GAME ACCOSTANO I MODULI DELLE LIBRERIE SNAKE E LEAF CON PERFETTA CORRISPONDENZA DI MISURE • IT COMBINES THEM WITH THE IRREGULAR MODULES OF THE SNAKE AND LEAF BOOKCASES WITH PERFECTLY CORRESPONDING MEASUREMENTS.

PIANI DI FORTE SPESSORE

MENSOLE DI DIVERSO SPESSORE E TOP DI FORTE IMPATTO, POSIZIONABILI ANCHE VERTICALMENTE, DISEGNANO LINEE CROMATICHE SOTTILI. UNITE ALLO SCRITTOIO • SHELVES OF DIFFERENT THICKNESS AND STRONG-IMPACT TOPS, WHICH CAN ALSO BE POSITIONED VERTICALLY, DESIGN THIN COLOUR LINES.

MIX: THE SET OF MORE SYSTEMS

LIBRERIA SNAKE
SNAKE BOOKCASE

MENSOLE
SHELVES

SCRITTOIO POLIS
POLIS WRITING DESK

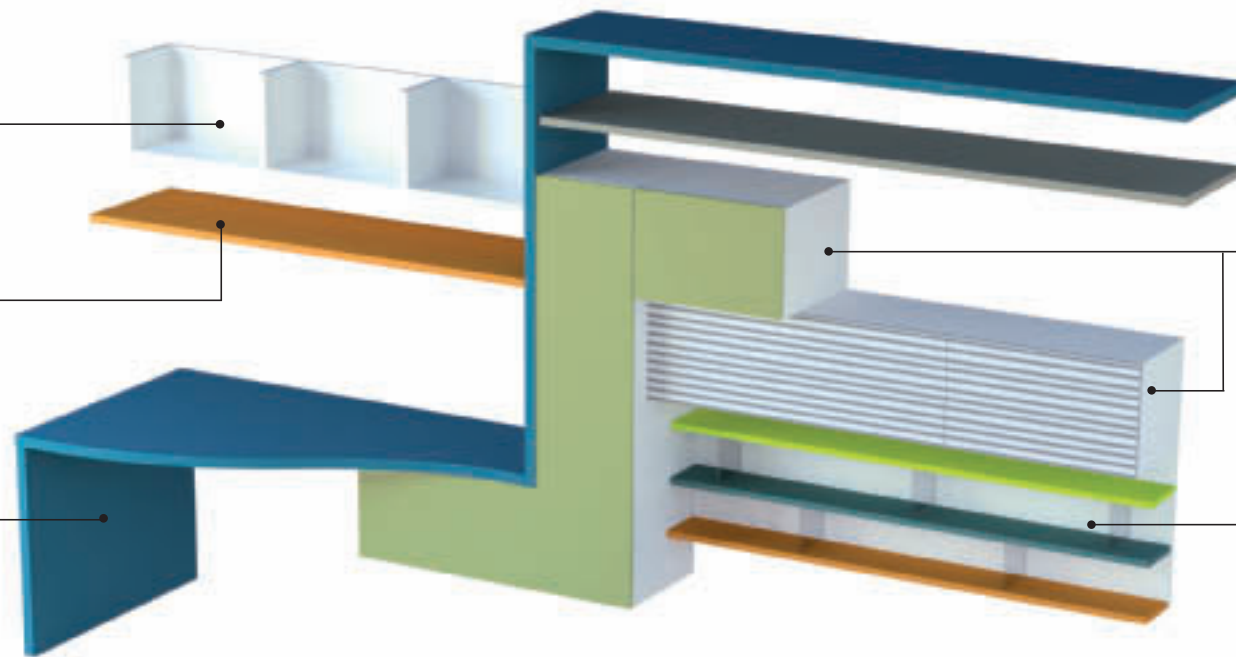

SISTEMA TOP
TOP SYSTEM

PENSILI GAME
GAME HANGING UNITS

LIBRERIA LEAF
LEAF BOOKCASE



MIX SYSTEM: INTEGRATING MORE FUNCTIONS

IL SISTEMA MIX CONSENTE DI INTERPRETARE LA PARETE CREATIVAMENTE CON COMPOSIZIONI SOSPESSE DI FORTE IMPATTO GRAFICO. MIXANDO OPPORTUNAMENTE I CONTENITORI GAME CON LE LIBRERIE SNAKE, GLI ALVEARI LEAF, LE MENSOLE E I TOP DI SISTEMA E I PIANI SAGOMATI SI OTTENGONO "ARCHITETTURE" INTEGRATE A PARETE DI GRANDE FASCINO ESPRESSIVO. LE FINITURE COLORE E LE ESSENZE GIOCANO UN RUOLO IMPORTANTE NELLA DEFINIZIONE DEL PROGETTO • THE MIX SYSTEM ALLOWS TO INTERPRET THE WALL CREATIVELY WITH SUSPENDED COMPOSITIONS OF GREAT GRAPHIC IMPACT. BY MIXING GAME BOXES PROPERLY WITH SNAKE BOOKCASES, LEAF HIVES, SHELVES AND SYSTEM TOPS AND SHAPED TOPS WE OBTAIN "ARCHITECTURES" INTEGRATED INTO THE WALL OF HIGHLY EXPRESSIVE CHARM. COLOR AND WOOD FINISHES PLAY AN IMPORTANT ROLE IN THE DEFINITION OF THE PROJECT.

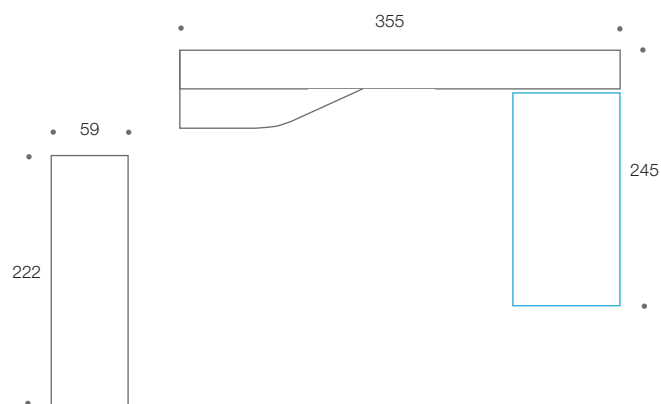

FINITURE - FINISHES (MELAMMINICI / LACCATI)
 OLMO PERLA, OLMO NATURALE, ROSA, CANARINO, BIANCO, CRETA.





613

SISTEMA MIX: ESEMPI DI COMPONIBILITÀ

ELEMENTI MIX

LA GRANDE PARETE È ATTREZZATA CON ELEMENTI PENSILI INTEGRATI A TOPS E PIANO STUDIO SAGOMATO OPPORTUNAMENTE MIXATI TRA LORO A FORMARE UNA COMPOSIZIONE ESTREMAMENTE FUNZIONALE DI GUSTO MATURO E DECISAMENTE CREATIVA NELL'ESPRESSIONE FORMALE • THE LARGE WALL IS FITTED OUT WITH WALL ELEMENTS INTEGRATED WITH TOPS AND SHAPED STUDY TOP SUITABLY MIXED TOGETHER TO FORM AN EXTREMELY FUNCTIONAL COMPOSITION OF MATURE TASTE AND DECIDEDLY CREATIVE IN ITS FORMAL EXPRESSION.



SOLUZIONI PERSONALIZZATE

IL SISTEMA TOP ORIZZONTALE E VERTICALE DISEGNA GEOMETRIE ESSENZIALI CHE "GUIDA" LO SVILUPPO DELLE COMPOSIZIONI A PARETE. I PIANI DI LAVORO SI INTEGRANO CON I CONTENITORI PENSILI, LE MENSOLE E GLI ELEMENTI A GIORNO LEAF • A SYSTEM OF HORIZONTAL AND VERTICAL TOPS DESIGN ESSENTIAL GEOMETRIES THAT "GUIDE" THE DEVELOPMENT OF THE WALL COMPOSITIONS. THE WORKTOPS INTEGRATE WITH THE WALL, STORAGE UNITS, THE SHELVES AND THE LEAF OPEN-FRONT ELEMENTS.



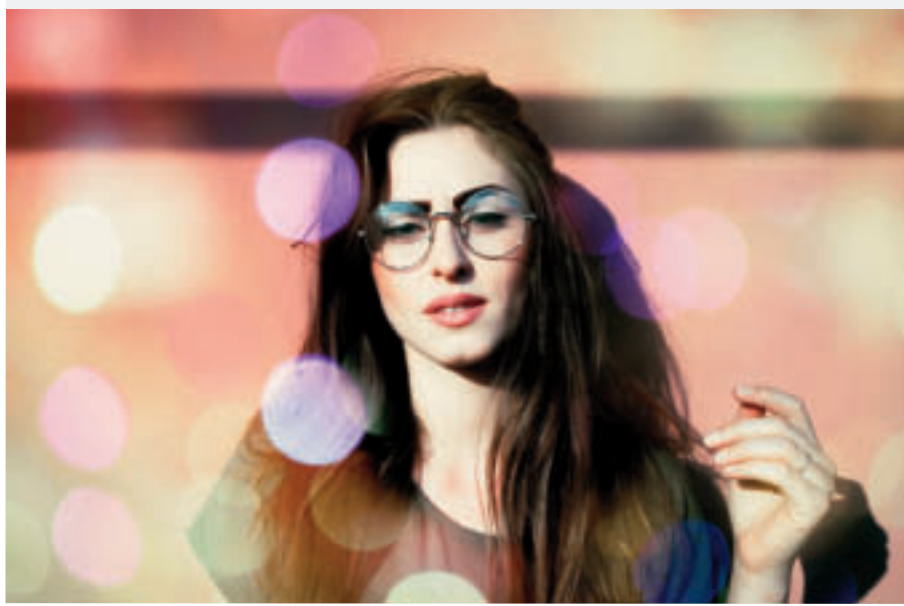

MIX STUDY ZONE

LA GRANDE PARETE È ATTREZZATA CON ELEMENTI PENSILI INTEGRATI A TOP E PIANO STUDIO SAGOMATO OPPORTUNAMENTE MIXATI TRA LORO A FORMARE UNA COMPOSIZIONE ESTREMAMENTE FUNZIONALE, DI GUSTO MATURO E DECISAMENTE CREATIVA NELL'ESPRESSIONE FORMALE

• THE LARGE WALL IS FITTED OUT WITH WALL ELEMENTS INTEGRATED WITH TOPS AND SHAPED STUDY TOP SUITABLY MIXED TOGETHER TO FORM AN EXTREMELY FUNCTIONAL COMPOSITION OF MATURE TASTE AND DECIDEDLY CREATIVE IN ITS FORMAL EXPRESSION.

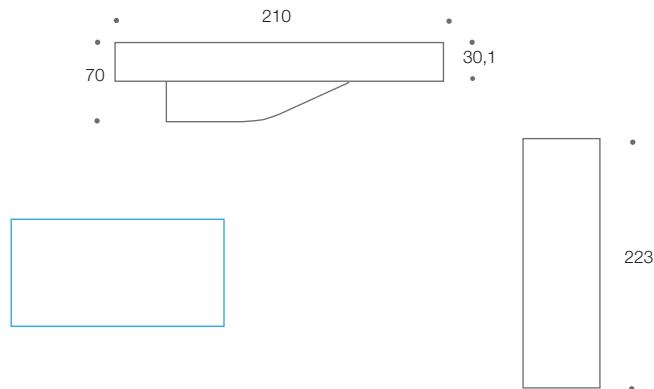

FINITURE - FINISHES (MELAMMINICI / LACCATI)
 OLMO PERLA, OLMO CENERE.





614

SISTEMA MIX: PROPOSTE COMPOSITIVE

CONTENITORI GAME

ANCHE I CONTENITORI GAME DISEGNANO PERCORSI A PARETE. SONO INTERPRETABILI IN MELAMMINICO ESSENZA O COLORE • ALSO THE GAME CABINETS DRAW ROUTES ON THE WALL. THEY CAN BE AVAILABLE IN WOODEN FINISH MELAMINE OR COLOURED.

PIANI STUDIO

I PIANI STUDIO INTEGRATI DI FORTE SPESSORE CARATTERIZZANO IL SISTEMA MIX. POSSONO ESSERE REALIZZATI LINEARI O SAGOMATI • THE INTEGRATED STUDY DESKS WITH STRONG THICKNESS CHARACTERIZE THE MIX SYSTEM. THEY CAN BE PRODUCED LINEAR OR SHAPED.



MENSOLE DI FORTE SPESSORE

IL SISTEMA TOP ORIZZONTALE E VERTICALE DISEGNA GEOMETRIE ESSENZIALI CHE "GUIDANO" LO SVILUPPO DELLE COMPOSIZIONI A PARETE. I PIANI DI LAVORO SI INTEGRANO CON I CONTENITORI PENSILI, LE MENSOLE E GLI ELEMENTI A GIORNO LEAF • A SYSTEM OF HORIZONTAL AND VERTICAL TOPS DESIGN ESSENTIAL GEOMETRIES THAT "GUIDE" THE DEVELOPMENT OF THE WALL COMPOSITIONS. THE WORKTOPS INTEGRATE WITH THE WALL, STORAGE UNITS, THE SHELVES AND THE LEAF OPEN-FRONT ELEMENTS.





TEXTURE AS A WALLPAPER

UNA TEXTURE MACRO APPLICATA A PARETE RENDE L'AMBIENTE IRONICO E GRAFICO. I COLORI "FRESCHI" DELLE LACCATURE DIALOGANO CON IL GRAPHIC DESIGN DELLE FACCIATE. UNA PROPOSTA CONTEMPORANEA PER L'AREA GIOVANE • A MACRO TEXTURE APPLIED ON THE WALL MAKES THE AMBIENCE IRONIC AND GRAPHIC. THE "FRESH" LACQUERING COLOURS DIALOG WITH THE GRAPHIC DESIGN OF THE FRONTS. A CONTEMPORARY PROPOSAL FOR THE YOUNG AREA.

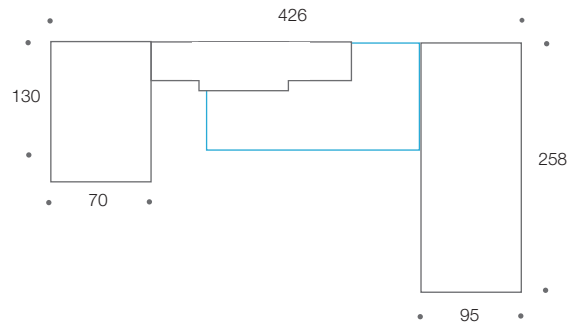

FINITURE - FINISHES (MELAMMINICI / LACCATI)
 BIANCO, GRIGIO CHIARO, GRIGIO SCURO, CANAPA, SENAPE,
 CANARINO, TURCHESE.

TEXTURE COME PARATI





614



615



MIX COMPOSITION WITH WALL PLACED PANELING

COMPOSIZIONE A PARETE CON LETTO E SCRITTOIO INTEGRATI ALLA BOISERIE A MURO. IL GIOCO DELLE DIVERSE PROFONDITÀ AMPLIFICA LA PERCEZIONE DELLO SPAZIO E L'ORGANIZZAZIONE RAZIONALE DELL'AMBIENTE • WALL COMPOSITION WITH BED AND DESK INTEGRATED TO THE WALL PANELING. THE GAME OF THE DIFFERENT DEPTHS AMPLIFIES THE PERCEPTION OF SPACE AND THE RATIONAL PLANNING OF THE AMBIENCE.

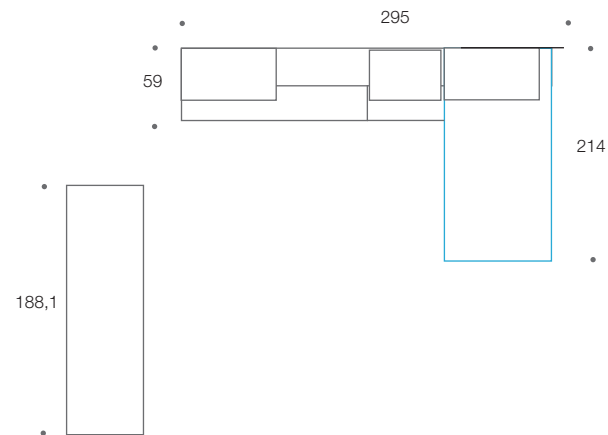

FINITURE - FINISHES (MELAMMINICI / LACCATI)
 OLMO NATURALE, OLMO PERLA, PETROLIO2, GRIGIO CHIARO.
 TEXTURETRATTO.



THE "OBJECTUAL" COMPOSITION

NON SEMPRE SERVONO GRANDI PROGETTI PER ARREDARE BENE UNA CAMERETTA... A VOLTE BASTANO PICCOLI MA BILANCIATI ELEMENTI PER CREARE LA GIUSTA ATMOSFERA. QUESTE COMPOSIZIONI "OGGETTUALI" INTERPRETANO IL SISTEMA MIX COME UN'OCCASIONE PER CREARE RAFFINATI COMPOSÉ A PARETE • NOT ALWAYS BIG PROJECTS ARE NEEDED TO WELL FURNISH A BEDROOM ...SOMETIMES ONLY LITTLE BUT BALANCED ELEMENTS CAN BE ENOUGH TO CREATE THE RIGHT ATMOSPHERE. THESE "OBJECTUAL" COMPOSITIONS TRANSLATE THE MIX SYSTEM IN AN OPPORTUNITY TO CREATE REFINED WALL SOLUTIONS.

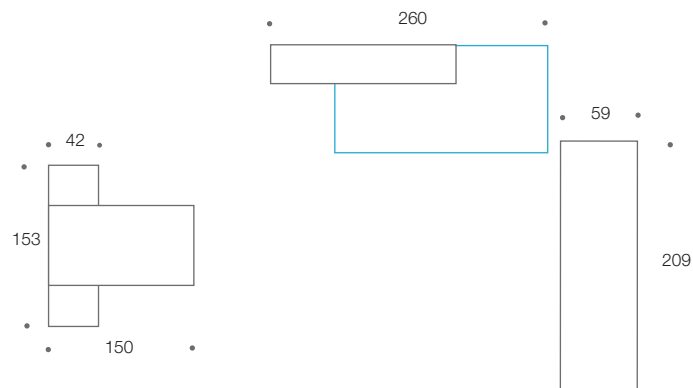

FINITURE - FINISHES (MELAMMINICI / LACCATI)
 OLMO PERLA, OLMO CENERE, ROSA, BIANCO, PRUSSIA.

LA COMPOSIZIONE "OGGETTUALE"





616



LETTO STYLE PIAZZA E MEZZO



IL LETTO "FOR SINGLE"

STYLE È UN PROGETTO-LETTO CHE CONSENTE DIVERSE CONFIGURAZIONI, SIA PER L'ASPETTO DIMENSIONALE CHE PER LE FINITURE • "STYLE" IS A PROJECT-BED THAT ALLOWS DIFFERENT CONFIGURATIONS, BOTH FOR THE DIMENSIONAL SETTING AND THE FINISHES.

QUEEN SIZE "STYLE" BED



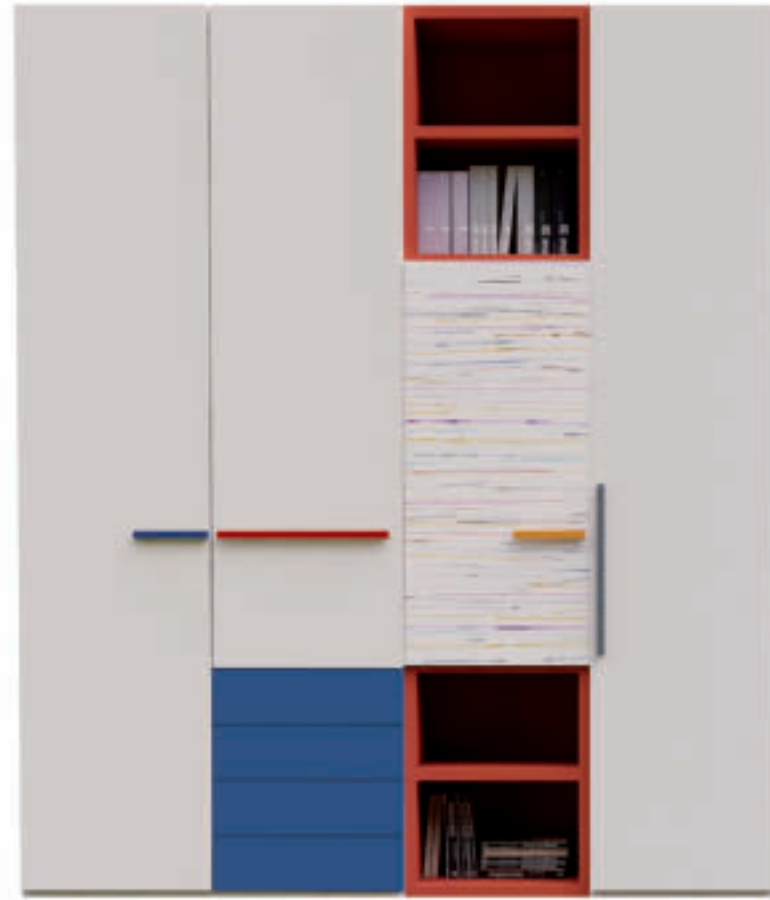

CHEST OF DRAWERS: LAYOUT OF THE FACADE

L'ARMADIO MOSTRA UN'INTERESSANTE SOLUZIONE PROGETTUALE: UNA CASSETTIERA INTEGRATA A FACCIATA E, INTERNAMENTE, UN VANO UNICO CHE PERMETTE DI SFRUTTARE A PIENO LO SPAZIO INTERNO • THE WARDROBE SHOWS AN ATTRACTIVE PROJECT SOLUTION: A FRONT INTEGRATED CHEST OF DRAWERS AND INTERNALLY A WHOLE SPACE WHICH ALLOWS YOU A BEST USE OF THE INSIDE SPACE.

CASSETTIERA: LA GRAFICA DELLE FACCIATE



617

A SPACE FOR TWO

UNO SPAZIO PER DUE



ACCOSTARE DUE LETTI

I LETTI TESSILI ANGOLARI DANNO VITA ALL'AREA RIPOSO/CONVERSAZIONE DOVE SI POSSONO RICEVERE AMICI • THE CORNER TEXTILE BEDS GIVE LIFE TO THE REST/CONVERSATION AREA IN WHICH YOU CAN MEET YOUR FRIENDS.

IL GRANDE PIANO SAGOMATO

IN LUCE AGLI ELEMENTI PENSILI IL GRANDE PIANO LAVORO /STUDIO È IDEALE ANCHE PER I DISPOSITIVI MOBILE • IN BETWEEN THE WALL CABINETS THE BIG WORKING/STUDYING DESK IS IDEAL ALSO FOR MOBILE DEVICES.

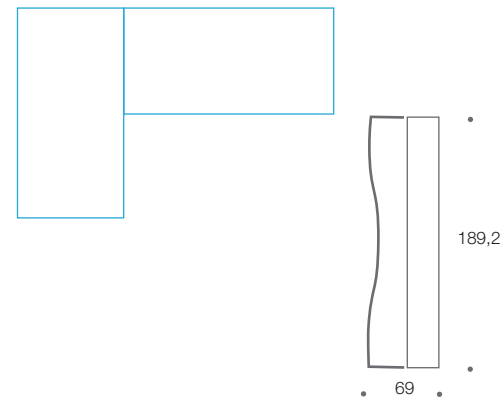

FINITURE - FINISHES (MELAMMINICI / LACCATI)
OLMO NATURALE, ROSA. ORIENTE, LAMPONE, BIANCO, GRIGIO CHIARO.





ANGULAR BEDS



LETTI ANGOLARI

DUE RAGAZZI TROVANO UN'ADEGUATA SISTEMAZIONE IN UN'UNICA CAMERA GRAZIE ALLA DUTTILE COMPONIBILITÀ DEGLI ELEMENTI CHE COSTITUISCONO L'ARREDO. I LETTI SI ACCOSTANO E IL GRANDE PIANO SAGOMATO È ASSISTITO DA UNA COMPOSIZIONE PENSILE • TWO KIDS FIND THE PERFECT SET IN THE SAME BEDROOM, THANKS TO THE GREAT MODULARITY OF THE FURNISHING ELEMENTS. THE BEDS CAN BE PULLED TOGETHER AND THE BIG SHAPED DESK IS SERVED BY A SUSPENDED COMPOSITION.



COORDINATED FINISHES

UN RAFFINATO GIOCO DI LACCATURE E TEXTURE BIANCONERO È ASSOCIATO AD UN COLORE DAL CARATTERE DECISO. IL CAPIENTE ARMADIO CON ANTE SCORREVOLI È RISOLTO CON LE TEXTURE RIGA E PUNTO CHE RICORDANO L'ARTE CINETICA • A REFINED GAME OF LACQUERINGS AND TEXTURE BLACK/WHITE IS ASSOCIATED TO A COLOUR WITH INTENSIVE CHARACTER. THE SPACIOUS WARDROBE WITH SLIDING DOORS IS EQUIPPED WITH TEXTURES RIGA AND PUNTO WHICH RECALL THE KINETIC ART.

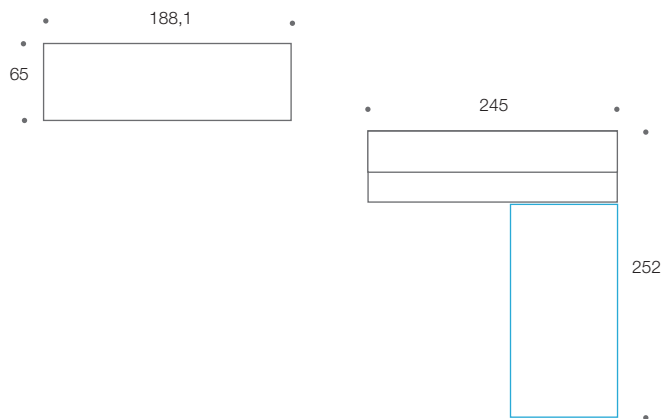

FINITURE - FINISHES (MELAMMINICI / LACCATI)
 BIANCO, GRIGIO SCURO, LAMPONE. TEXTURE RIGA E PUNTO.





618

619



INTERGRADED STUDY ZONE



ZONA STUDIO INTEGRATA

IL LETTO LEGNO MASSELLO

UN LETTO PARTICOLARMENTE IDONEO PER UN RAGAZZO ADULTO IN VERSIONE PIAZZA E MEZZO • A PARTICULARLY SUITABLE QUEEN BED FOR A YOUNG ADULT.

LIBRERIA E CONTENITORI PENSILI

LA LIBRERIA SNAKE È ASSOCIATA AGLI ELEMENTI PENSILI A CONTENERE. PIANO CON FIANCO A TERRA • THE SNAKE BOOKCASE IS ASSOCIATED TO THE CONTAINING WALL CABINETS. DESK WITH FLOOR STANDING SIDE.

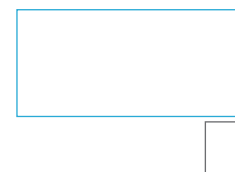
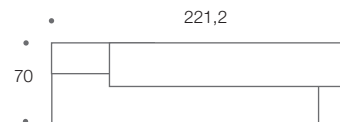

FINITURE - FINISHES (MELAMMINICI / LACCATI)
OLMO NATURALE, GRIGIO CHIARO, PETROLIO.



SOLID WOOD BED



IL LETTO MASSELLO

GRATIFICANTE, COMODO E BEN DISEGNATO, IL LETTO LOBBY È PROPOSTO IN LEGNO MASSELLO LACCATO OPACO. È UNA PROPOSTA IMPORTANTE DI GRANDE PERSONALITÀ DISTINTIVA... UN CLASSICO SENZA TEMPO • REWARDING, COMFORTABLE AND WELL DESIGNED, THE BED LOBBY IS PROPOSED IN MATT LACQUERED SOLID WOOD, IT'S AN IMPORTANT PROPOSAL WITH GREAT DISTINCTIVE PERSONALITY... A TIMELESS CLASSIC.



EQUIPPED PANELING

LA BOISERIE CONSENTE UNA DINAMICA DEGLI ELEMENTI INTEGRATI A PARETE. IL LETTO, LA SCRIVANIA E LA LIBRERIA SI UNISCONO ALLA BOISERIE A MURO PER UN AMBIENTE COORDINATO E FUNZIONALE. • THE PANELING ALLOWS A DYNAMIC OF THE WALL INTEGRATED ELEMENTS. THE BED, THE DESK AND THE BOOKCASE ARE CONNECTED WITH THE WALL PANELING FOR A COORDINATED AND FUNCTIONAL AMBIANCE.

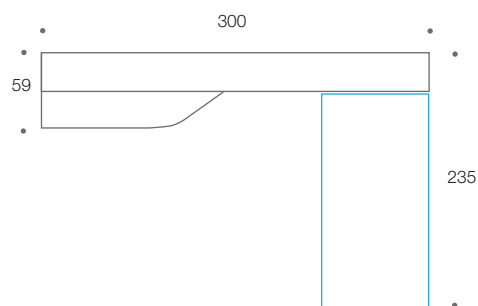

FINITURE - FINISHES (MELAMMINICI / LACCATI)
OLMO NATURALE, BIANCO, CORDA2, SENAPE, MUSCHIO, PETROLIO2.

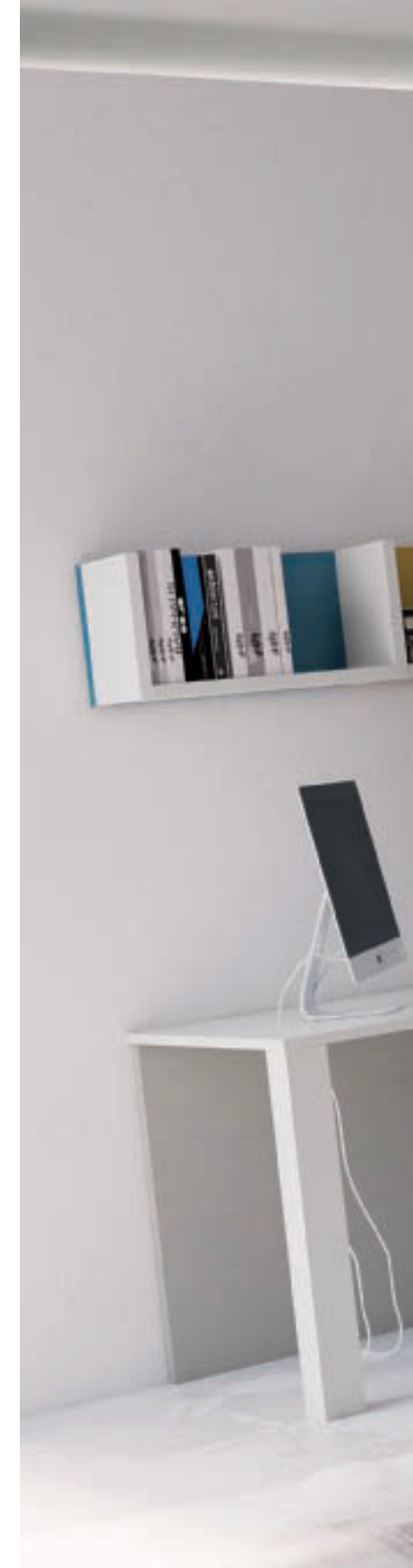



620



COMPORRE... COME UN PUZZLE

LO SCRITTOIO INTEGRATO

LO SCRITTOIO INTEGRATO ALLA BOISERIE A PARETE E ALL'ELEMENTO LIBRERIA COME UN GIOCO AD INCASTRO • THE DESK INTEGRATED TO THE WALL PANELING AND TO THE BOOKCASE ELEMENT LIKE A PUZZLE GAME.

LACCATI ED NOBILITATO ESSENZA

IL SISTEMA CROMATICO DIELLE PRESENTA TONALITÀ RICERCATE E MAI BANALI CHE SI ASSOCIANO AL MELAMMINICO ESSENZA • THE DIELLE CHROMATIC SYSTEM PRESENTS SOPHISTICATED AND NEVER BANAL SHADES ASSOCIATING WITH THE WOODEN FINISH MELAMINE.

COMPOSING... LIKE A PUZZLE



LA LIBRERIA SNAKE INTEGRATA

LA LIBRERIA SNAKE È FACILMENTE AGGREGABILE AI CONTENITORI GAME E ALLE BOISERIE • THE SNAKE BOOKCASE IS EASILY CONNECTABLE TO THE GAME CABINETS AND TO THE PANELINGS.

IL GIOCO DEI CONTENITORI

SPESSE IL PROGETTO DELL'AREA STUDIO DEVE OTTIMIZZARE AL MASSIMO PICCOLI SPAZI CON SOLUZIONI FUNZIONALI • THE STUDY AREA PROJECT OFTEN HAS TO FULLY OPTIMIZE THE LITTLE SPACES WITH FUNCTIONAL SOLUTIONS.

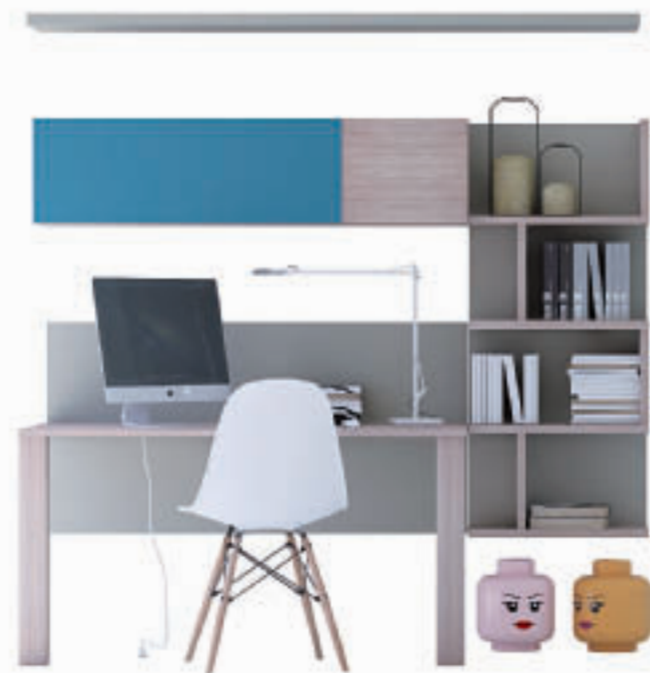



621



CONTEMPORARY CHROMATICISMS



CROMATISMI CONTEMPORANEI

LE FUNZIONI A PARETE

UNA BILANCIATA SIMMETRIA DI ELEMENTI A PROFONDITÀ DIFFERENZIATA CARATTERIZZA QUESTE PROPOSTE LUMINOSE E SOLARI. IL LETTO XBED ACCOSTATO AL PIANO SAGOMATO SI INTEGRA PERFETTAMENTE NELLA RAFFINATA COMPOSIZIONE A PARETE • A BALANCED SYMMETRY OF DIFFERENTIATED DEPTH ELEMENTS CHARACTERIZES THESE LUMINOUS AND SOLAR PROPOSALS. THE XBED PLACED BESIDE THE SHAPED WORKTOP PERFECTLY INTEGRATES IN THE REFINED WALL COMPOSITION.

COLORI A CONTRASTO

NOTE DI COLORE PURO SONO ACCOSTATE AL LACCATO OPACO BIANCO E ALLE TEXTURE RIGA E PUNTO • NOTES OF PURE COLOUR ARE COMBINED WITH THE WHITE MATT LACQUER, WITH THE TEXTURES RIGA AND PUNTO.

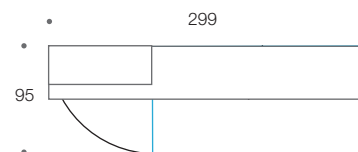

FINITURE - FINISHES (MELAMMINICI / LACCATI)
BIANCO, BLU, GRIGIO SCURO, MUSCHIO, ZUCCA.



621

IL LETTO IN APPOGGIO

THE BED IN SUPPORT



IL LETTO TESSILE PUÒ ESSERE ATTREZZATO CON CASSETTO-CONTENITORE. I TESSUTI SONO COORDINATI ALLE FINITURE DI SISTEMA XBED È UN PROGETTO-LETTO TOTALMENTE INNOVATIVO PER LE SOLUZIONI TECNICHE PRESENTATE E PER IL DESIGN ACCATTIVANTE E IN UN CERTO SENSO ANCHE LUDICO E DIVERTENTE. IL CASSETTO, COME IL PIEDE DI SOSTEGNO, È UN BREVETTO DEPOSITATO DA DIELE SPA • XBED IS A TOTALLY INNOVATIVE BED PROJECT INTERMS OF THE TECHNICAL SOLUTIONS PRESENTED AND FOR THE APPEALING DESIGN IN A CERTAIN SENSE ALSO PLAYFUL AND AMUSING. A PLAYFUL AND CREATIVE IDEA BASED ON GEOMETRIC ELEMENTS WITH PURE AND INTENSE FREELY-COMBINABLE COLOURS. THE DRAWER LIKE THE SUPPORT FOOT ARE BOTH GRAPHIC ELEMENTS.

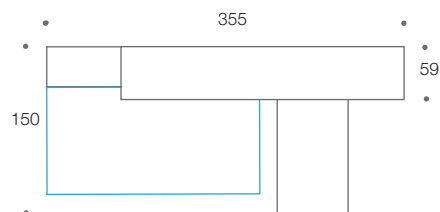

FINITURE - FINISHES (MELAMMINICI / LACCATI)
 OLMO PERLA, GRIGIO SCURO, PETROLIO2, GIRASOLE, GRIGIO CHIARO.
 TEXTURE ARLECCHINO, RIGA..



PALO ALTO NUOVO SISTEMA LIBRERIA

C04

LA LIBRERIA STUDIO

SISTEMA PALO ALTO ELEMENTI AGGREGABILI LIBRERIA A GIORNO ATTREZZATA CON SCRITTOIO INTEGRATO • PALO ALTO SYSTEM ATTACHABLE ELEMENTS OPEN BOOKSHELF EQUIPPED WITH INTEGRATED DESK.

ACCOSTARE DUE MODULI

ACCOSTANDO DUE O PIÙ ELEMENTI LIBRERIA PALO ALTO SI OTTENGONO COMPOSIZIONI RAPPRESENTATIVE PER OGNI AMBIENTE • CONNECTING TWO OR MORE PALO ALTO BOOKCASE ELEMENTS YOU CAN OBTAIN REPRESENTATIVE COMPOSITIONS FOR EVERY AMBIANCE.

ZONA STUDIO EVOLUTA

NON IL SOLITO SCRITTOIO, MA UNA POSTAZIONE STUDIO AD ELEVATA FUNZIONALITÀ DESTINATA A DURARE NEL TEMPO • NOT THE USUALLY DESK, BUT A VERY FUNCTIONAL STUDY WORKSTATION DESTINED TO LAST IN TIME.

PALO ALTO: NEW BOOKCASE SYSTEM



SISTEMA PALO ALTO: ELEMENTI LIBERAMENTE AGGREGABILI

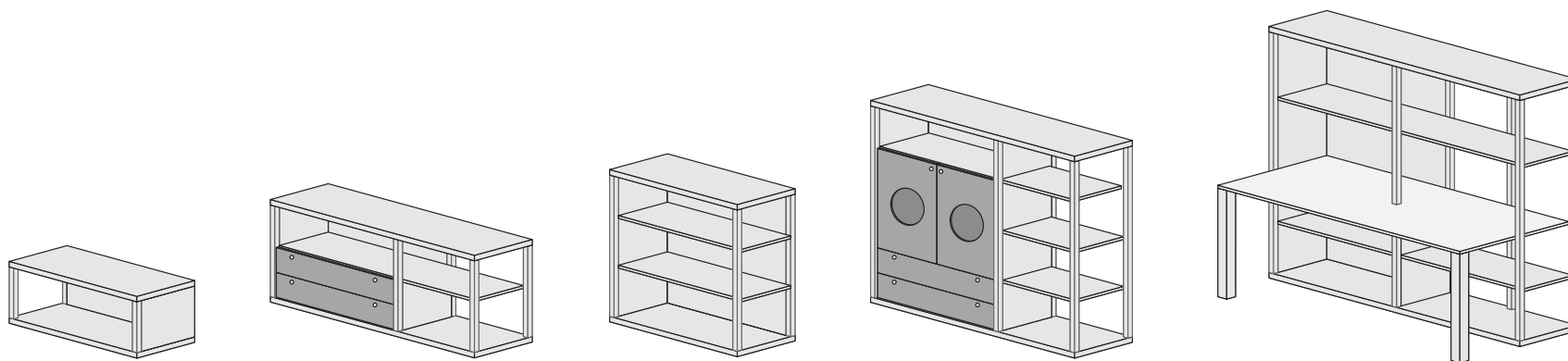
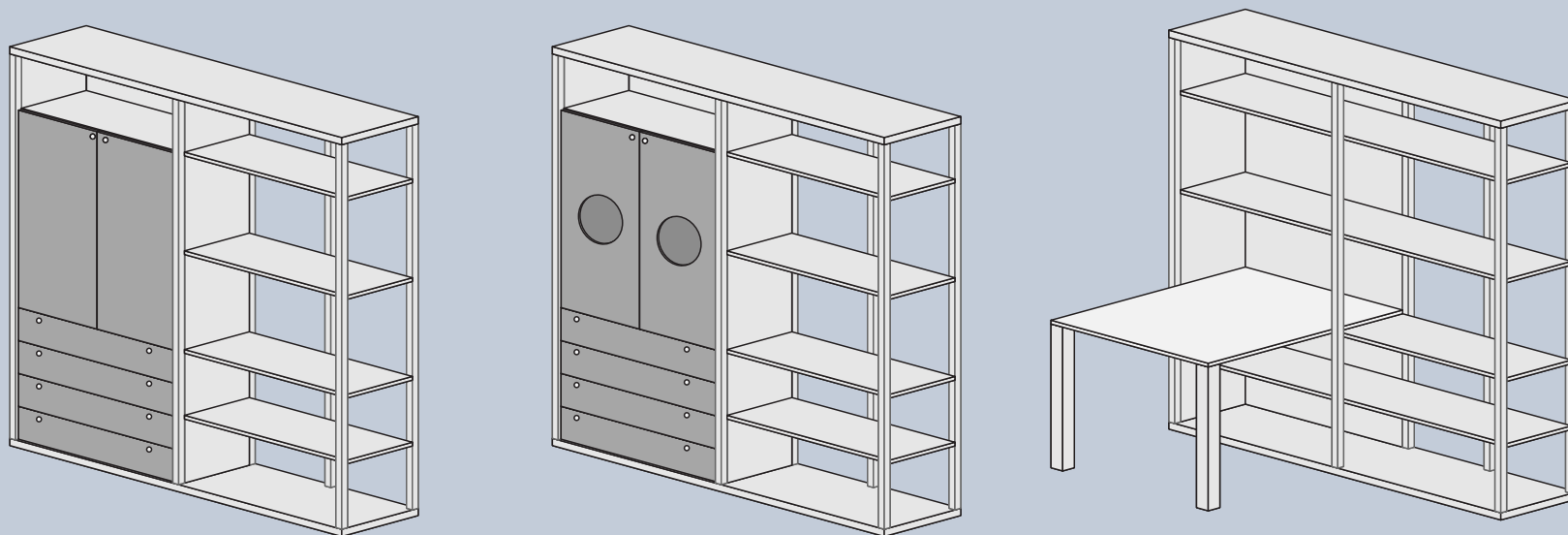

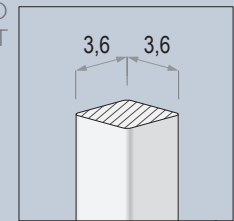

- 01 SPALLA / TRAMEZZA sp. 3,5 cm**
LE SPALLE VENGONO FORATE E ATTREZZATE IN CORRISPONDENZA DEGLI ACCESSORI (RIPIANI, CASSETTI, ANTE ETC.) • THE SIDE AND THE PARTITION PANELS ARE PIERCED AND EQUIPPED FOR THE ASSEMBLY OF THE ACCESSORIES.
- 02 PALI sp. 3,6x3,6 cm**
DISPONIBILI NELLE FINITURE OLMO PERLA, OLMO NATURALE, OLMO CENERE, BIANCO, CORDA2, E IN TUTTE I COLORI LACCATI • THE STRUCTURE'S POLES ARE AVAILABLE IN FINISHES OLMO PERLA, OLMO NATURALE, OLMO CENERE, BIANCO, CORDA2, AND IN ALL LACQUERED COLOURS.
- 03 RIPIANI LEGNO sp. 1,8cm/3,5 cm**
VENGONO FISSATI ALLE SPALLE TRAMITE REGGIPIANI AD INSERIMENTO VERTICALE • THE WOODEN SHELVES ARE FIXED TO THE SIDE PANELS THROUGH HOLDERS FOR VERTICAL ASSEMBLY.
- 04 SCHIENALE sp. 1,8 cm**
PANNELLO IN MELAMMINICO • MELAMINE BACK PANEL.
- 05 ANTA LEGNO sp. 1,8 cm**
ANTA IN LUCE ALLA STRUTTURA • WOODEN DOOR FLUSH WITH THE STRUCTURE.
- 06 CASSETTI**
SONO DOTATI DI GUIDE QUADRO CON MOTO SILENZIATO E CHIUSURA AMMORTIZZATA NEGLI ULTIMI 60 MM DI CORSA • THE DRAWERS ARE EQUIPPED WITH RUNNERS "QUADRO" WITH SILENT SYSTEM AND SOFT CLOSE DAMPENING IN THE LAST 60 MM OF STROKE.

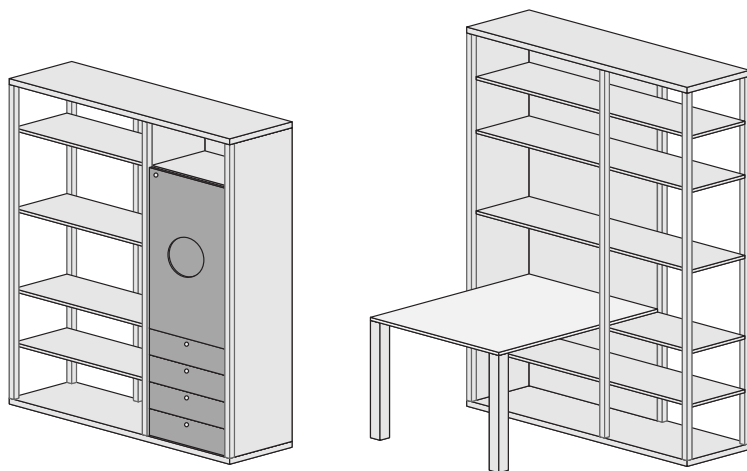
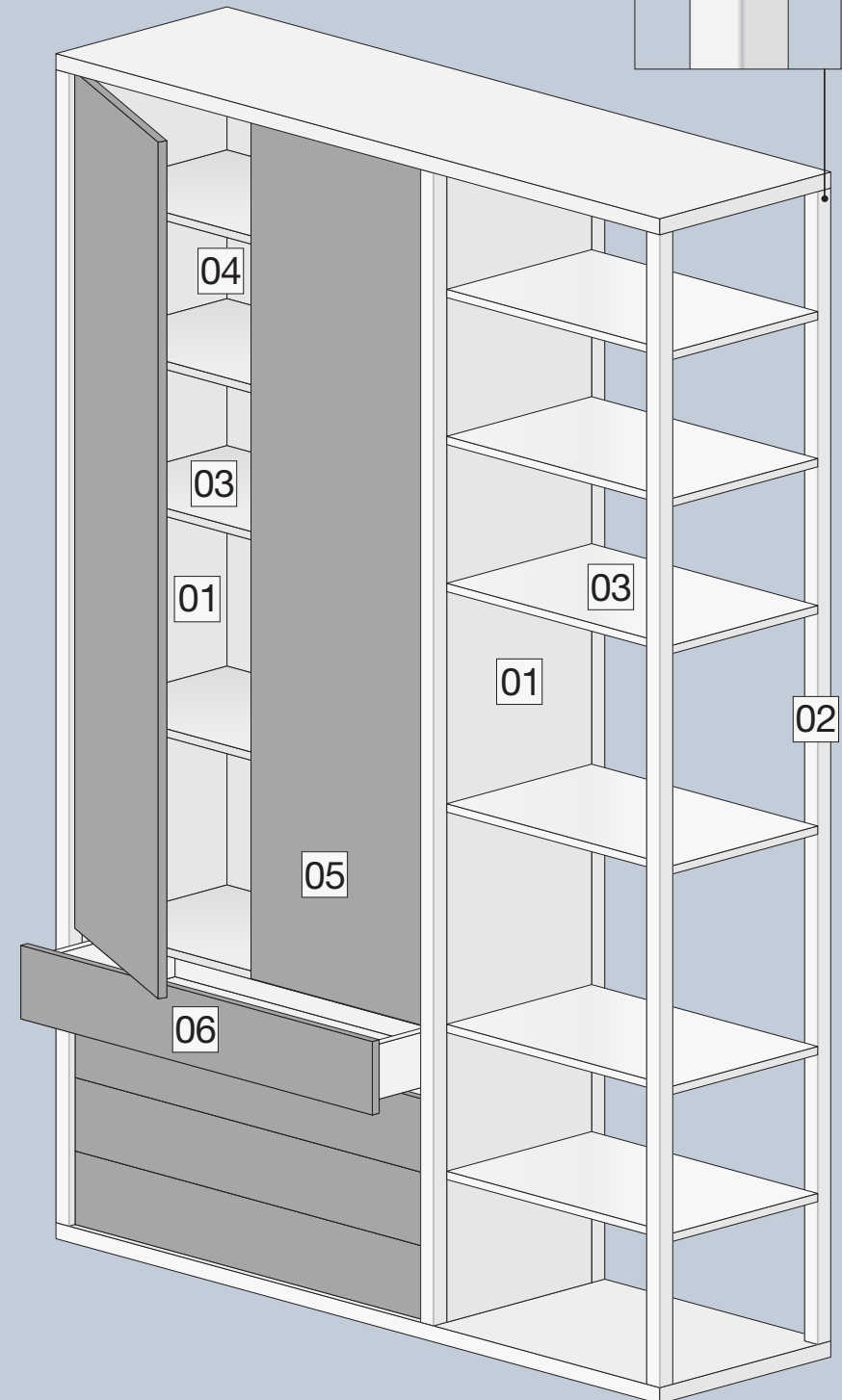

UNA STANZA PER DUE



A BEDROOM FOR TWO

LA COLLEZIONE STYLE PROPONE UNA VASTA GAMMA DI LETTI PROPOSTI NELLE CONFIGURAZIONI PIÙ FUNZIONALI E RAPPRESENTATIVE. ZONA RIPOSO CON LETTO STYLE LACCATO ORIENTE CON GAMBA TROTTOLA IN FINITURA ARGENTATA E LETTO STYLE LACCATO POLVERE GAMBA SFERA IN LEGNO. GLI ELEMENTI LUDICI CARATTERIZZANO LA PROPOSTA

• THE STYLE COLLECTION PROPOSES A WIDE RANGE OF BEDS AVAILABLE IN THE MOST FUNCTIONAL AND REPRESENTATIVE CONFIGURATIONS. RESTING ZONE WITH ORIENTE LACQUERED STYLE BED WITH SILVER FINISHED TROTTOLA LEG, POLVERE LACQUERED STYLE BED. THE PLAYFUL ELEMENTS CHARACTERIZE THE PROPOSAL.

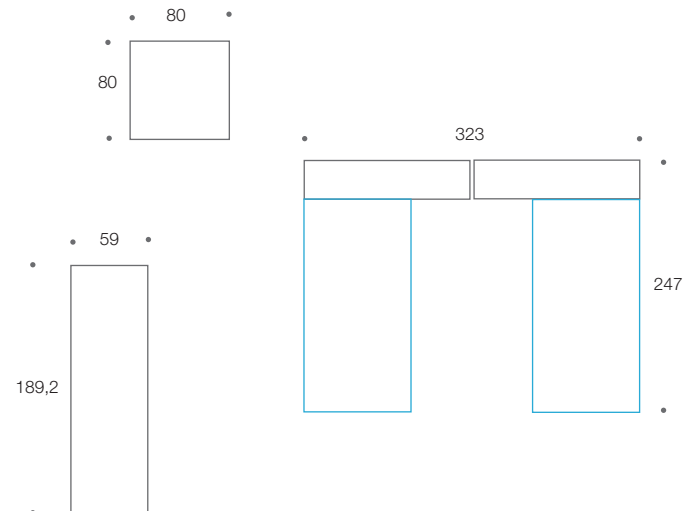

FINITURE - FINISHES (MELAMMINICI / LACCATI)
OLMO PERLA, AVIO, ORIENTE, TEXTURE TRATTO.



622



BOOKCASE WITH BED AND DESK

ZONA RIPOSO CON LETTO STYLE, SISTEMA PALO ALTO ELEMENTI AGGREGABILI LIBRERIA A GIORNO ATTREZZATA CON SCRITTOIO INTEGRATO. LETTO STYLE LACCATO POLVERE CON GIROLETTO RIVESTITO IN TESSUTO COORDINATO, GAMBA SFERA IN LEGNO • RESTING AREA WITH STYLE BED, PALO ALTO SYSTEM ATTACHABLE ELEMENTS OPEN BOOKSHELF EQUIPPED WITH INTEGRATED DESK. POLVERE LACQUERED STYLE BED WITH COORDINATED FABRIC COVERED BEDFRAME, RAW SOLID WOOD SPHERICAL LEG.

LIBRERIA CON LETTO E SCRITTOIO

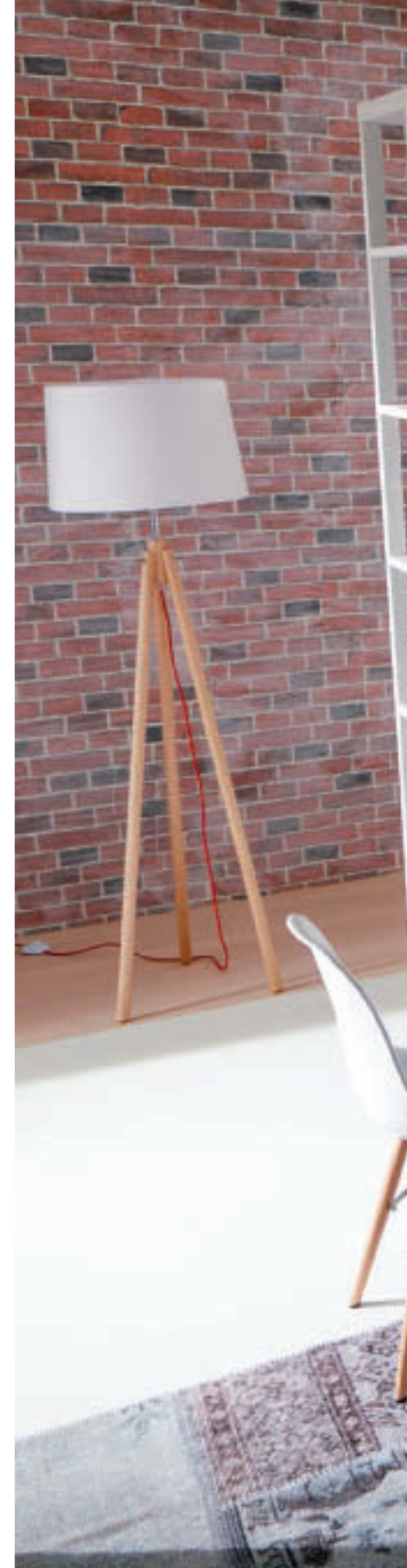



623



LA GRAFICA DELLE MANIGLIE



THE HANDLES' GRAPHIC



L'ARMADIO COORDINATO E GIOCOSO

ARMADIO COORDINATO LACCATO BIANCO CON MANIGLIE TEXTURE TRATTO. LA SEMPLICITÀ DEGLI ELEMENTI È VALORIZZATA DA UN TOCCO CREATIVO DATO DAI GRANDI MANIGLIONI COLORATI CHE ESPRIMONO UN'IDENTITÀ GIOCOSA DEL PRODOTTO • COORDINATED WHITE LACQUERED WARDROBE WITH TRATTO TEXTURE HANDLES. THE ELEMENTS' SIMPLICITY IS ENHANCED BY THE CREATIVE TOUCH OF THE BIG COLOURED HANDLES THAT EXPRESS A PLAYFUL IDENTITY OF THE PRODUCT.

MANIGLIE & CREATIVITÀ

ANCHE LE MANIGLIE GIOCANO UN RUOLO IMPORTANTE NELL'IMPATTO VISIVO DI OGNI SINGOLA COMPOSIZIONE. DIELE PRESTA MOLTA ATTENZIONE A QUESTA TEMATICA CREATIVA SVILUPPANDO SOLUZIONI ORIGINALI E PROPOSITIVE • ALSO THE HANDLES PLAY AN IMPORTANT RULE IN THE VISUAL IMPACT OF EVERY SINGLE COMPOSITION. DIELE PAYS CAREFUL ATTENTION TO THIS CREATIVE TOPIC DEVELOPING ORIGINAL AND PURPOSEFUL SOLUTIONS.



624



IL LETTO NEOCLASSICO



THE NEOCLASSICAL BED

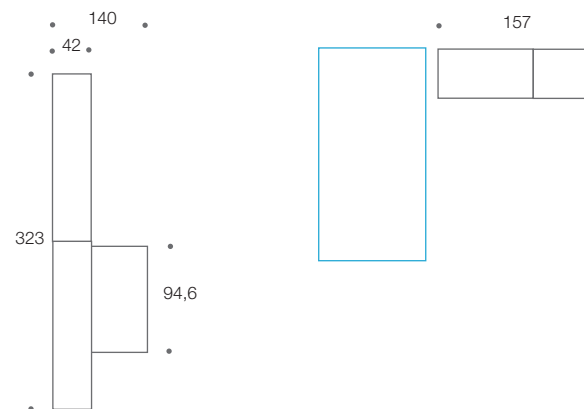

PALO ALTO ELEMENTI AGGREGABILI LIBRERIA A GIORNO ATTREZZATA IN NOBILITATO OLMO CENERE, SCRITTOIO DAL DISEGNO ESSENZIALE INTEGRATO ALLA LIBRERIA IN MELAMMINICO ESSENZA. LETTO STYLE STRUTTURA MELAMMINICO ESSENZA ET ESSUTO SFODERABILE. ARMADIO CON OBLÒ LACCATO BIANCO • PALO ALTO SYSTEM, COMBINABLE ELEMENTS, EQUIPPED OPEN BOOKSHELF IN MELAMINE, DESK WITH ESSENTIAL DESIGN CONNECTED TO THE BOOKSHELF IN WHITE LACQUERED. STYLE BED WITH MELAMINE STRUCTURE AND REMOVABLE FABRIC COATING. WARDROBE WITH WHITE LACQUERED PORTHOLE DOOR.

FINITURE - FINISHES (MELAMMINICI / LACCATI)
OLMO CENERE, BIANCO.



FURNISHING WITH CLASSICAL STYLE

PALO ALTO ELEMENTI AGGREGABILI LIBRERIA A GIORNO ATTREZZATA, STRUTTURA E RIPIANI IN MELAMMINICO, SCHIENALI LACCATO BIANCO, ANTA OBLÒ LACCATO BIANCO. SCRITTOIO DAL DISEGNO RACCORDATO CON GAMBETORNITE IN LEGNO MASSELLO LACCATO BIANCO E CANAPA, LETTO STYLE LACCATO CRETA CON PARTI IMBOTTITE RIVESTITE IN TESSUTO SFODERABILE • PALO ALTO SYSTEM COMBINABLE ELEMENTS EQUIPPED OPEN BOOKSHELF. STRUCTURE AND SHELVES IN MELAMINE, WHITE LACQUERED BACKS, WHITE LACQUERED PORTHOLE DOOR. BEAN-SHAPED DESK WITH SOLID WOOD TURNED LEGS IN WHITE OR LIGHT GREY LACQUERED FINISH, STYLE BED LIGHT GREY LACQUERED WITH PADDED PARTS CLAD IN REMOVABLE FABRIC COATING.

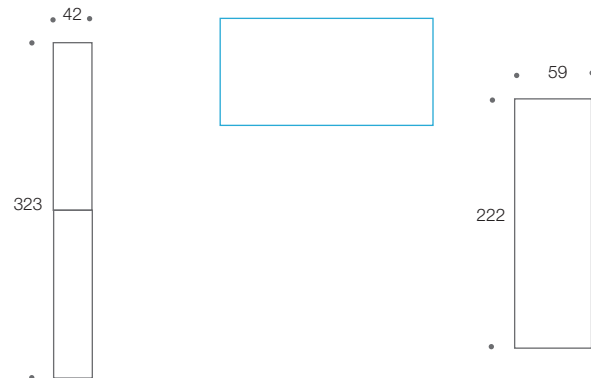

FINITURE - FINISHES (MELAMMINICI / LACCATI)
OLMO PERLA, BIANCO, GRIGIO CHIARO, GRIGIO SCURO, CANAPA.





625



THE MIDDLE-ROOM DESK

NEL SEGNO DI UNA PERSONALITÀ DISTINTIVA SI POSSONO COGLIERE DIVERSI VALORI FORMALI, ESPRESSIONE DELLA PROPRIA IDENTITÀ, DA INTERPRETARE A PIACERE. COSÌ CIÒ CHE ERA FONDAMENTALMENTE CLASSICO, ORA SI RIPROPONE SECONDO UN'IDEA DI COLORE E DI CARATTERE PIÙ PROPOSITIVO • IN THE SIGN OF A DISTINCTIVE PERSONALITY, DIFFERENT FORMAL VALUES CAN BE WELCOMED, EXPRESSIONS OF ONE'S IDENTITY, FOR A PERSONAL INTERPRETATION. WHAT WAS BASICALLY CLASSIC, NOW IT IS PRESENTED WITH AN IDEA OF COLOR AND A PROACTIVE ROLE.

FINITURE - FINISHES (MELAMMINICI / LACCATI)
 OLMO PERLA, BIANCO, CANARINO, ORIENTE, GLICINE.





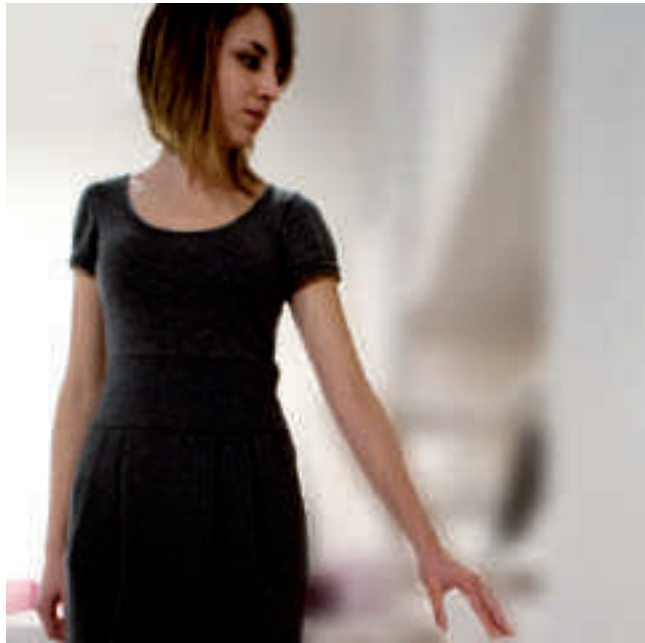

CUSTOMIZING FURNISHINGS

UN MIX DI ELEMENTI DI FORTE PERSONALITÀ COME IL LETTO STYLE PROTAGONISTA DELL'ARREDO. LA LIBRERIA PALO ALTO CON ANTA OBLÒ IN VERSIONE LACCATO COLORE • AN ELEMENT'S MIX OF STRONG PERSONALITY LIKE THE STYLE BED, FURNISHING PROTAGONIST. THE PALO ALTO BOOKCASE WITH PORTHOLE DOOR IN THE VERSION COLOURED MATT LACQUERED.

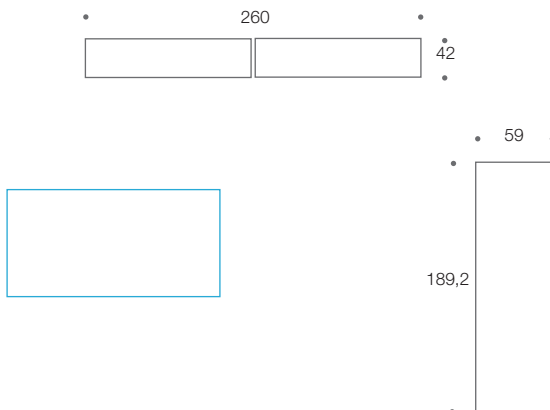

FINITURE - FINISHES (MELAMMINICI / LACCATI)
BANCO, CORDA2.





626

SCRIVANIA A PENISOLA



LIBRERIA PALO ALTO

PALO ALTO È UNA SOLUZIONE MODULARE CHE ACCOSTA PIANI LAVORO SAGOMATI PER CREARE ZONE STUDIO DI ALTEZZA E LARGHEZZA DIFFERENZIATE • PALO ALTO IS A MODULAR SOLUTION WHICH INCLUDES ALSO SHAPED WORK TOPS TO CREATE STUDY ZONES OF DIFFERENT HEIGHTS AND WIDTHS.

L'ANTA OBLÒ

L'ESCLUSIVA ANTA OBLÒ, IN LUCE RISPETTO AL MONTANTE, CARATTERIZZA IL DISEGNO DELLA COMPOSIZIONE STUDIO CHE PRESENTA ANTE E CASSETTI DI SERVIZIO ALLA SCRIVANIA • THE EXCLUSIVE PORTHOLE DOOR, POSITIONED INSIDE IN RELATION TO THE FRAME, CHARACTERIZES THE STUDY COMPOSITION DESIGN WHICH INCLUDES DOORS AND DRAWERS AS DESK SERVICE.







COMPOSING IN CONTINUITY



COMPORRE IN CONTINUITÀ

LE FUNZIONI SONO INDIPENDENTI, MA POSSONO ESSERE ACCOSTATE A PIACERE PER CREARE SPAZI IN CONTINUITÀ DI VOLUMI. TUTTI I SISTEMI DIELE SONO PERFETTAMENTE INTEGRATI PER ASPETTO ESTETICO E FINITURE • THE FUNCTIONS ARE INDEPENDENT, BUT THEY CAN BE APPROACHED TO CREATE SPACES IN VOLUMES CONTINUITY. ALL THE DIELE SYSTEMS ARE PERFECTLY INTEGRATED FOR AESTHETIC ASPECT AND FINISHES.

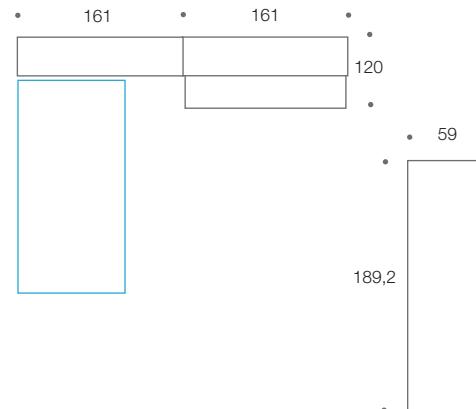

FINITURE - FINISHES (MELAMMINICI / LACCATI)
OLMO NATURALE, BIANCO, PETROLIO2, TEXTURE ARLECCHINO..



A CREATIVE AND FUNCTIONAL SOLUTION

IL SISTEMA CROMATICO CONSENTE DI PERSONALIZZARE L'AMBIENTE CON COLORI LACCATI E FINITURE MELAMMINICO DALLE CALDE TONALITÀ DEL LEGNO. ANCHE I TESSUTI DI RIVESTIMENTO E I COORDINATI TESSILI CONTRIBUISCONO AD UN PLANNING GIOVANE E "FRESCO. ANCHE L'ARMADIO PUÒ ESSERE PERSONALIZZATO, CON TEXTURE GRAFICHE OPPURE CON L'INSERIMENTO DI UN PORTA TV INTEGRATO • THE COLOUR SYSTEM PERMITS PERSONALISING THE ENVIRONMENT WITH LACQUERED COLOURS AND MELAMINE FINISHES WITH WARM WOOD SHADES. THE UPHOLSTERY FABRICS AND THE COORDINATED TEXTILES ALSO CONTRIBUTE TO YOUNG AND "FRESH" PLANNING. EVEN THE WARDROBE CAN BE CUSTOMIZED, WITH GRAPHIC TEXTURES OR EVEN WITH AN INTEGRATED TV RACK.









PALO ALTO BOOKCASE



ALTERNANDO SOLUZIONI A GIORNO AD ELEMENTI PANNELLATI SI POSSONO REALIZZARE COMPOSIZIONI SOLIDE SENZA RINUNCIARE A UN'IDEA DI LEGGEREZZA VISIVA. IL DESIGN DELLA LIBRERIA PALO ALTO CONSENTE DI POSIZIONARE IL LETTO IN APPOGGIO E INTEGRARE IL PIANO SCRIVANIA, CONSENTENDO DI CREARE UNA PARETE ALL-IN-ONE DI GRANDE VALORE SIA ESTETICO CHE FUNZIONALE.

• INTERCHANGING OPEN SOLUTIONS AND ELEMENTS WITH PANELS, IT IS POSSIBLE TO MAKE SOLID COMPOSITIONS WITHOUT GIVING AWAY LIGHTNESS. THE DESIGN OF THE PALO ALTO BOOKCASE ALLOWS AN ADJACENT PLACING OF THE BED AND COMPLETING WITH A WRITING DESK, CREATING A "ALL IN ONE" WALL OF GREAT AESTHETIC AND FUNCTIONAL VALUE.

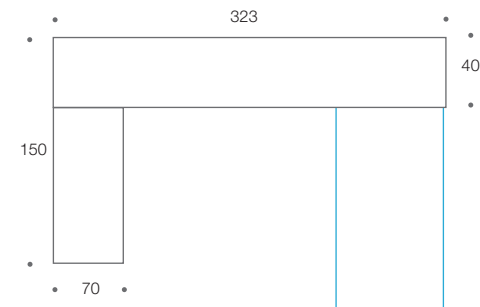



628

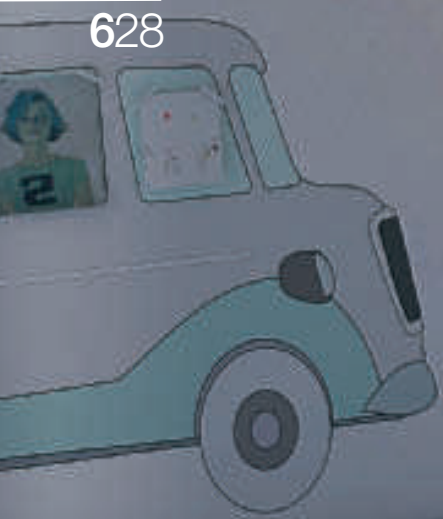



IL LETTO IN APPOGGIO

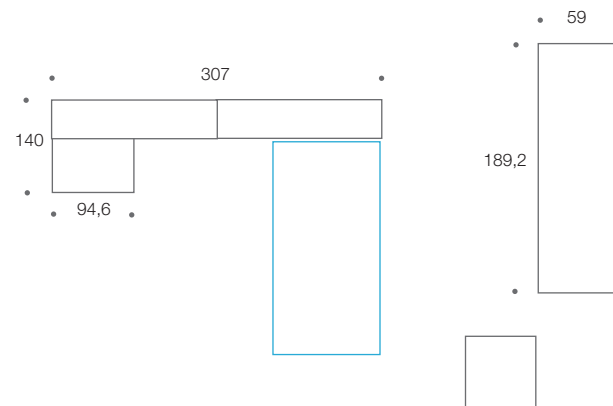

FINITURE - FINISHES (MELAMMINICI / LACCATI)
BIANCO, MANDARINO, CANARINO, TURCHESE.

IL LETTO IN APPOGGIO ALLA LIBRERIA

LA LIBRERIA PALO ALTO È STUDIATA PER ACCOGLIERE I LETTI E LA SCRIVANIA COORDINATI, CREANDO UN "UNICUM" DI GRANDE EFFETTO • THE PALO ALTO BOOKSHELF IS DESIGNED TO HOST THE MATCHED BEDS AND DESKS, CREATING A UNIQUE, AMAZING COMPOSITION.

LO STICKER CAMIONCINO

LO STICKER CAMIONCINO PORTA ALLEGRIA NELL'AREA GIOVANE, È COORDINABILE CON LE FINITURE DEGLI ARREDI • THE TRUCK STICKER BRINGS JOY IN THE KIDS' AREA, IT IS POSSIBLE TO MATCH IT WITH THE FINISHES OF THE FURNITURE.

THE BED IN SUPPORT



LINEAR WALL



PARETE LINEARE

LIBRERIA RETROLETTO

LA LIBRERIA PALO ALTO SI OFFRE AI LETTI ACCOSTATI COME SPAZIO DI SERVIZIO ED ALLA SCRIVANIA COME DOTAZIONI STUDIO • THE PALO ALTO BOOKSHELF IS A USEFUL SPACE TO THE MATCHED BEDS AND STUDYING EQUIPMENT TO THE DESK.

COLORI DI TENDENZA

LE PALETTE DEL SISTEMA CROMATICO DIELE SONO PROPOSTE DI TENDENZA CON UNA RICCA TAVOLOZZA DI COLORI • THE PALETTES OF THE DIELE CHROMATIC SYSTEM ARE SOME TRENDING PROPOSALS WITH A RICH SELECTION OF COLORS.

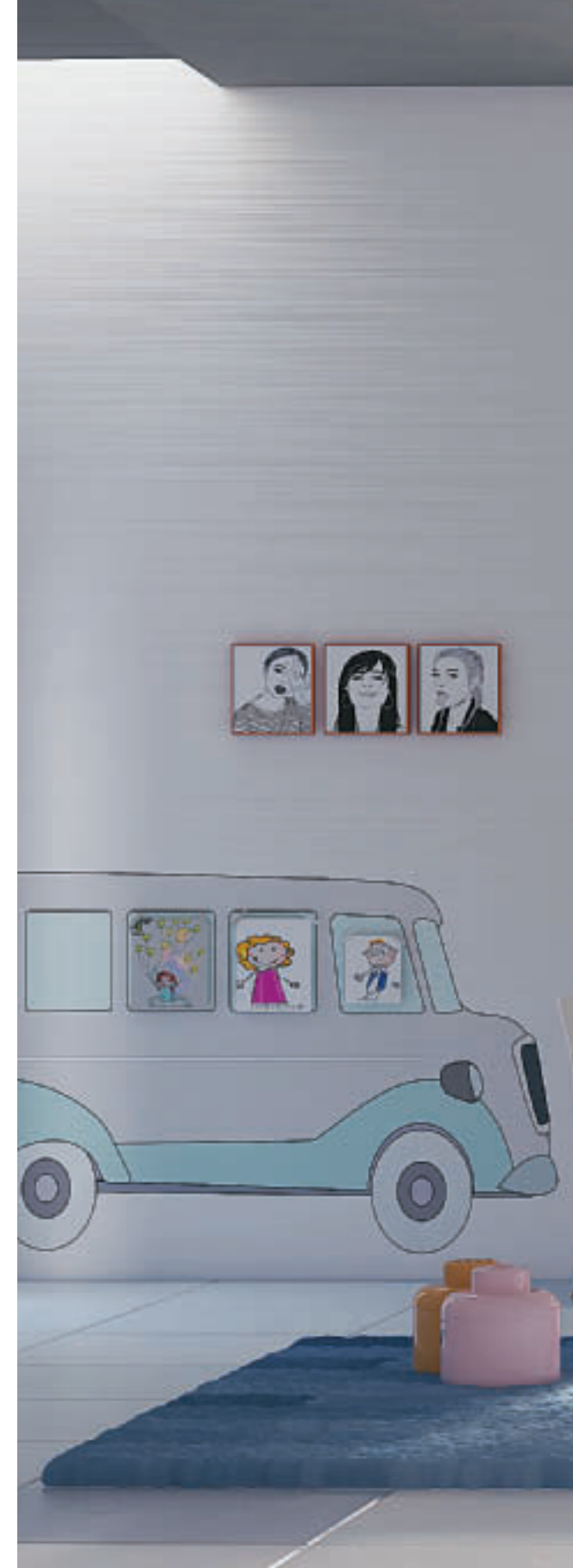



LA LIBRERIA, LO STUDIO, IL RIPOSO

INTEGRARE LETTO E SCRITTOIO

IN POCO SPAZIO È POSSIBILE INTEGRARE SIA IL LETTO CHE LA SCRIVANIA CREANDO UN INSIEME FUNZIONALE E COMPATTO • IT IS POSSIBLE TO INTEGRATE THE BED AND THE DESK IN A LITTLE SPACE, CREATING A COMPACT AND FUNCTIONAL SET.

UNO O DUE LETTI IN APPOGGIO

UNA LIBRERIA A TRE MODULI È LA SOLUZIONE IDEALE PER ACCOGLIERE DUE LETTI INDIPENDENTI CON ZONA STUDIO CENTRALE. IL FONDALE PUÒ ESSERE REALIZZATO CON LE TEXTURE DIELLE • A THREE-MODULES BOOKCASE IS THE IDEAL SOLUTION FOR TWO INDEPENDENT BEDS WITH A CENTRAL STUDY AREA. THE BACKGROUND CAN BE DESIGNED WITH DIELLE TEXTURES.



LIBRERIA E CONTENERE

LA LIBRERIA PALO ALTO, QUI PRESENTATA IN ALTEZZA CM 194, È PROPOSTA CON COLONNE A GIORNO OPPURE CON SCHIENALE E TRAMEZZE • THE PALO ALTO BOOKCASE, HERE PROPOSED HEIGHT CM 194, IS AVAILABLE WITH OPEN TALL ELEMENTS OR WITH SIDE/BACK PANELS.

LIBRERIA E STUDIO

LO SCRITTOIO È INTEGRATO NELLA STRUTTURA COSÌ DA DIVENIRE UNA VERA E PROPRIA POSTAZIONE STUDIO-GIOCO • THE DESK IS INTEGRATED IN THE STRUCTURE BECOMING THEREFORE AN AUTHENTIC STUDYING-PLAYING WORKSTATION.



629





UN SIMPATICO LETTINO

SOLUZIONE MINIMALISTA

LE PROPOSTE DIELE SONO VERSATILI E FUNZIONALI. SONO PRODOTTI CHE ESSECONDANO LA CRESCITA DEI FIGLI CON SOLUZIONI PER OGNI ETÀ • DIELE SOLUTIONS ARE VERSATILE AND FUNCTIONAL, THEY ARE PRODUCTS THAT SUPPORT THE KIDS' GROWTH WITH SOLUTIONS FOR ALL AGES.

UN PEZZO "GIOCOLO"

UN LETTINO CHE RICORDA UN TOPOLINO ESPRIME IL CARATTERE LUDICO E GIOCOLO DELLO SPAZIO PENSATO PER I BAMBINI • A LITTLE BED THAT RESEMBLES A MOUSE EXPRESSES THE PLAYFUL DISPOSITION OF THE KIDS' AREA.

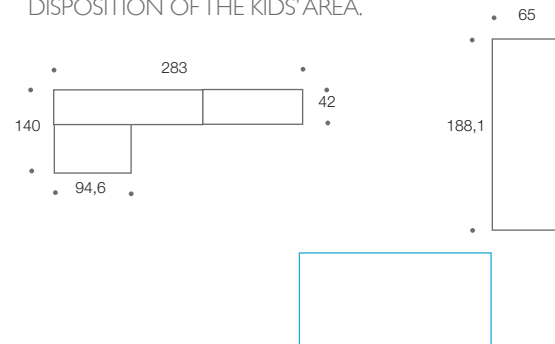

FINITURE - FINISHES (MELAMMINICI / LACCATI)
BIANCO, GRIGIO CHIARO, TEXTURE CARBONCINO.



630



PROTECTION E SOLUTION: I PANNELLI A MURO

UNA GRANDE VERSATILITÀ PROGETTUALE CHE PERMETTE DI AVERE UN'INFINITÀ DI SOLUZIONI DIFFERENTI PER OGNI ESIGENZA. DUE LETTI SINGOLI POSSONO ESSERE CORREDATI CON LE TESTIERE DI SISTEMA - QUI PROPOSTA LA TESTIERA "TOPINO" IN DUE VERSIONI - OPPURE CON PANNELLI DI PROTEZIONE PROTECTION E SOLUTION, IN LAMINATO O IMBOTTITI. I LETTI INOLTRE POSSONO ESSERE DOTATI DI CASSETTONI • A BIG PROJECT VERSATILITY ALLOWING A MULTITUDE OF DIFFERENT SOLUTIONS FOR EVERY NEED. TWO SINGLE BEDS CAN BE EQUIPPED WITH THE SYSTEM HEADBOARDS – HERE PROPOSED WITH "LITTLE MOUSE" HEADBOARD IN TWO VERSIONS – OR WITH PROTECTION AND SOLUTION PANELS, LAMINATE OR UPHOLSTERED. THESE BED CAN BE ALSO EQUIPPED WITH BIG DRAWERS.

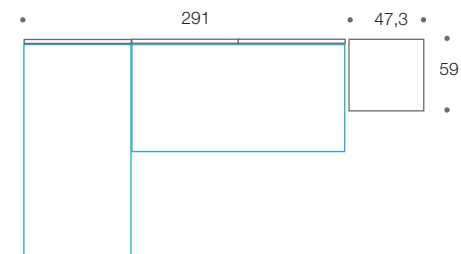

FINITURE - FINISHES (MELAMMINICI / LACCATI)
BIANCO, ROSA, ALABASTRO. PANNELLATURE IMBOTTITE PROTECTION.

LIBRERIA COME RETROLETTO



IL RIPOSO, LO STUDIO... E IL CONTENERE

IL GRADO DI PERSONALIZZAZIONE È CURATO IN OGNI DETTAGLIO SIA PER LE SCELTE CROMATICHE CHE PER LE FINITURE PIÙ APPROPRIATE E DISTINTIVE • THE LEVEL OF CUSTOMIZATION IS WELL-FINISHED IN EVERY DETAIL, BOTH THE CHROMATIC SELECTION AND THE MOST DISTINCTIVE AND APPROPRIATE FINISHES.

LA PARETE MULTIFUNZIONE

IL LETTINO SOTTOPONTE È UN'IDEA PRATICA E FUNZIONALE GRAZIE ALLA COLONNA DI SERVIZIO SOTTOPONTE • THE UNDER-BRIDGE BED IS A HANDY AND FUNCTIONAL IDEA, THANKS TO THE UNDER-BRIDGE SERVICE COLUMN.

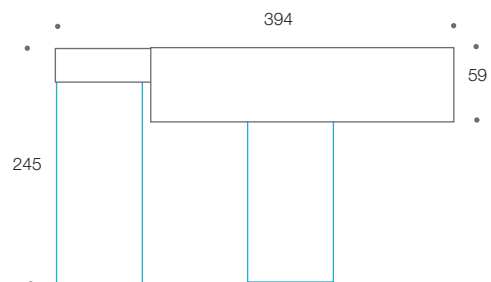

FINITURE - FINISHES (MELAMMINICI / LACCATI)
OLMO PERLA, CANAPA, NUVOLO.

THE BOOKSHELF AS THE BACKSIDE OF THE BED





631

LIBRERIA INTEGRATA AL PONTE

LA LIBRERIA ACCOSTA DUE LETTI

LA LEGGEREZZA È UNO DEI PLUS DISTINTIVI DELLA LIBRERIA PALO. UNA SOLIDA STRUTTURA CONSERVA TUTTA LA SUA LEGGEREZZA GRAZIE ALL'ASSENZA DI FIANCHI PORTANTI • LIGHTNESS IS ONE OF THE DISTINCTIVE FEATURES OF THE PALO BOOKSHELF. A SOLID STRUCTURE KEEPS ALL ITS LIGHTNESS DUE TO THE ABSENCE OF SUPPORTING SIDES.

UN GRANDE PIANO DI LAVORO

LA LIBRERIA PALO È VALORIZZATA NELLE VERSIONI NOBILITATO OLMO PROPOSTE NELLE VARIANTI OLMO PERLA, OLMO NATURALE E OLMO CENERE • THE PALO BOOKSHELF IS VALORIZED IN ENNOBLED ELM VERSIONS, WHICH ARE PROPOSED IN THE VARIATIONS OF PEARL ELM, NATURAL ELM AND ASH-COLOURED ELM.



IL LETTO LONGITUDINALE, LA SCRIVANIA PERPENDICOLARE
ALLA LIBRERIA PALO PUÒ ESSERE ACCOSTATO UN LETTO OPPURE
UNA SCRIVANIA, AUMENTANDO LA FUNZIONALITÀ DEL PRODOTTO
• A BED OR A DESK CAN BE MATCHED WITH THE PALO BOOKSHELF,
INCREASING THE FEATURES OF THE PRODUCT.





MASTER SISTEMA INTEGRALE D'ARREDAMENTO

C05

MODULARITÀ PER OGNI SPAZIO

MASTER SI NOTA SUBITO PER LO SPESSORE IMPORTANTE DEI PIANI E DEI FIANCHI (35 MM) FORNITI IN TUTTI I COLORI. SI PROPONE COME IL MIGLIOR SISTEMA IN GRADO DI RISOLVERE LA PROGETTAZIONE DELLA LIBRERIA E DELLA ZONA STUDIO. I SUOI NUMERI ESTENDONO LE POSSIBILITÀ DI ALLESTIRE L'AREA GIORNO, L'HOME OFFICE, ALTRE ZONE DELLA CASA... MA IL PUNTO DI FORZA È LA CAPACITÀ DI INTEGRARSI PERFETTAMENTE PER ASPETTO ESTETICO, MODULARITÀ E FINITURE CON I SISTEMI VIP, GAME, SNAKE E LEAF. SI POSSONO RIPENSARE LE COMPOSIZIONI GIOCANDO SULLA CADENZA REGOLARE DELLA SUA GRIGLIA, CONTRAPPORRE I PIANI IRREGOLARI DELLA LIBRERIA SNAKE, INTERSECCARE CON PROFONDITÀ DI VOLUMI DEI PENSILI GAME, PROLUNGARE PIANI CON SCRIVANIE E TOP DI PARI SPESSORE E MATERIALE, CONTRAPPORRE MENSOLE SOTTILI E COLORATE DELLA LIBRERIA LEAF • MASTER STANDS OUT IMMEDIATELY IN TERMS OF THE EXTRA THICKNESS OF THE TOPS AND SIDES (35MM AVAILABLE IN ALL COLOURS). THIS IS THE VERY BEST AVAILABLE SYSTEM FOR SOLVING BOOKCASE AND STUDY AREA PLANNING PROBLEMS. ITS FEATURES EXTEND THE POSSIBILITY OF SETTING UP THE DAY AREA, THE HOME OFFICE, AND OTHER PARTS OF THE HOME... BUT ITS STRONG POINT IS ITS ABILITY TO INTEGRATE PERFECTLY IN TERMS OF LOOKS, MODULARITY AND FINISHES WITH THE VIP, GAME, SNAKE AND LEAF SYSTEMS. COMPOSITIONS CAN BE REVISED BY PLAYING WITH THE REGULAR FLOW OF ITS GRILLE, CONTRASTING THE IRREGULAR SHELVES OF THE SNAKE BOOKCASES, INTERSECTING WITH THE VOLUME DEPTHS OF THE GAME HANGING UNITS, EXTENDING TOPS WITH WRITING DESKS AND OTHERS OF EQUAL THICKNESS AND THE SAME MATERIALS, AND CONTRASTING THE SLIM AND COLOURED SHELVES OF THE LEAF BOOKCASE.

DIELLE
GRUPPO DOIMO

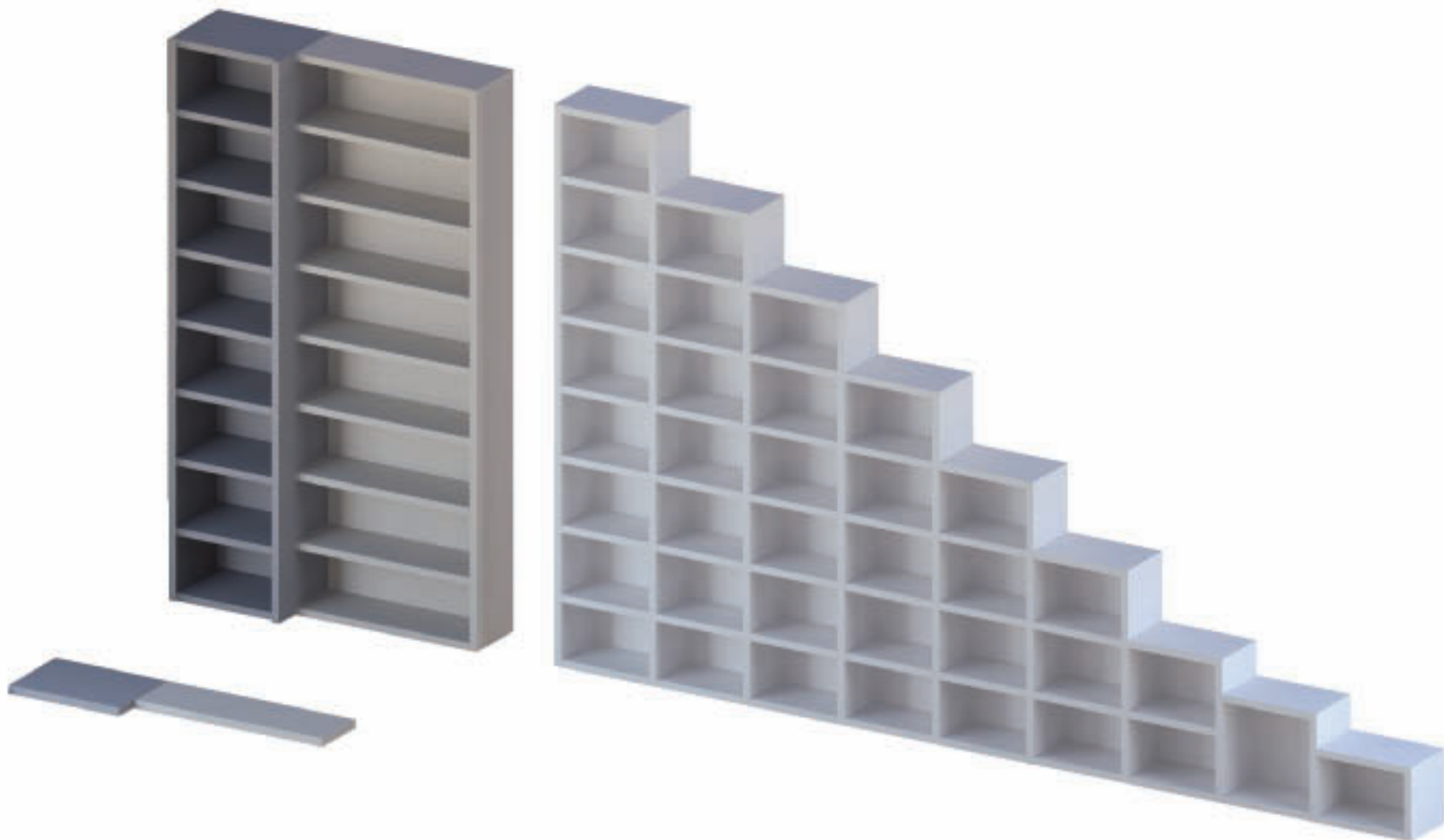

LA LIBRERIA INCASSATA A MURO



IL LETTO COMBINATO

AD UNO STESSO GIROLETTO SI POSSONO ASSOCIARE DIVERSE TESTIERE SAGOMATE COSÌ DA CREARE NUOVE FORME E MODELLI • SEVERAL DIFFERENT SHAPED HEADBOARDS CAN BE ASSOCIATED TO THE SAME BEDFRAME JUST TO CREATE NEW SHAPES AND MODELS.

LA TEXTURE CARBONCINO

PERSONALIZZARE CON LE TEXTURE DIELE È UN'IDEA CREATIVA DI GRANDE EFFETTO SCENOGRAFICO, SIA PER PICCOLI INSERTI CHE PER GRANDI SUPERFICI • CUSTOMIZING WITH DIELE TEXTURES IS A CREATIVE IDEA WITH A GREAT VISUAL EFFECT, BOTH FOR LITTLE INSERTS AND FOR BIGGER SURFACES.

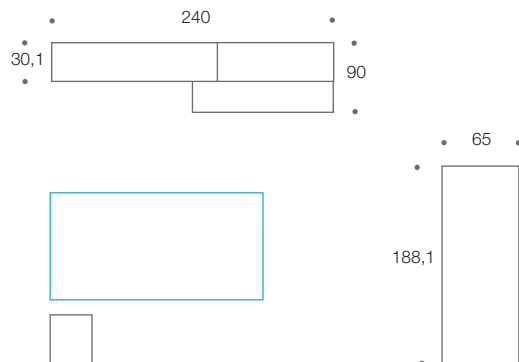

FINITURE - FINISHES (MELAMMINICI / LACCATI)
OLMO PERLA, BIANCO, TEXTURE CARBONCINO.







633

LA LIBRERIA PASSANTE



MASTER È LA LIBRERIA PASSANTE CON LA STESSA MODULARITÀ DEGLI ALTRI SISTEMI DIELE. QUI PROPOSTA NELLA VERSIONE INTER-PARETE CHE CREA UNA ZONA INGRESSO ALL'INTERNO DELLA STANZA. PUÒ ACCOSTARE DUE LETTI OPPURE UN LETTO ED UNA SCRIVANIA • MASTER IS THE DOUBLE-SIDED BOOKCASE WITH THE SAME MODULARITY OF THE OTHER DIELE SYSTEMS. HERE PROPOSED IN THE VERSION DIVIDING BOOKCASE WHICH CREATES AN ENTRANCE AREA INSIDE THE ROOM. IT CAN APPROACHES 2 BEDS OR 1 BED AND 1 WRITING DESK.

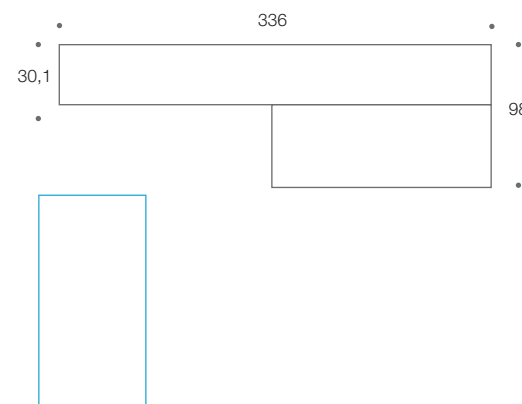

FINITURE - FINISHES (MELAMMINICI / LACCATI)
OLMO CENERE, GRIGIO CHIARO, GRIGIO SCURO, CANAPA, SENAPE, GIRASOLE.

DOUBLE-SIDED BOOKCASE





CHROMATISMS AND WALLPAPERS

LA CARTA PARATI È UN'ALTRA OCCASIONE DI PROGETTO PER UN AMBIENTE CURATO IN OGNI DETTAGLIO. I SOGGETTI DELLE CARTE PARATI SONO APPOSITAMENTE STUDIATI CON DELLE TONALITÀ IN NUANCES CON IL SISTEMA CROMATICO DIELE PER UN FACILE COORDINAMENTO • THE WALLPAPER IS ANOTHER PROJECT OCCASION FOR A WELL-FINISHED SPACE. THE SUBJECTS OF WALLPAPERS ARE SPECIFICALLY DESIGNED WITH SHADES OF THE DIELE CHROMATIC SYSTEM FOR AN EASY COORDINATION.

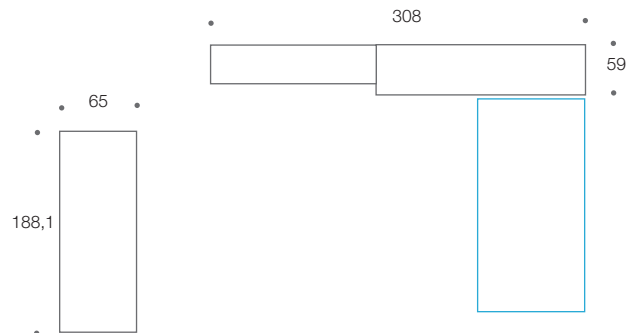

FINITURE - FINISHES (MELAMMINICI / LACCATI)
 OLMO NATURALE, MAGNOLIA, CORDA2, GRIGIO CHIARO, CRETA, MUSCHIO.





634



AN ELEGANT GAME OF NON-COLORS

IL MELAMMINICO ESSENZA DI OLMO NATURALE ASSOCIATO ALLE LUMINOSE TONALITÀ DELLE LACCATURE VALORIZZA LA COMPOSIZIONE GIOCATI SUI TONI DI NON-COLORI. LA LIBRERIA MASTER COMPLETA L'ARREDO • THE NATURAL ELM FINISH MELAMINE MATCHED WITH THE BRIGHT TONES OF LACQUERED ENHANCES THE COMPOSITION WITH NON-COLORS. THE MASTER BOOKSHELF COMPLETES THE FURNITURE.

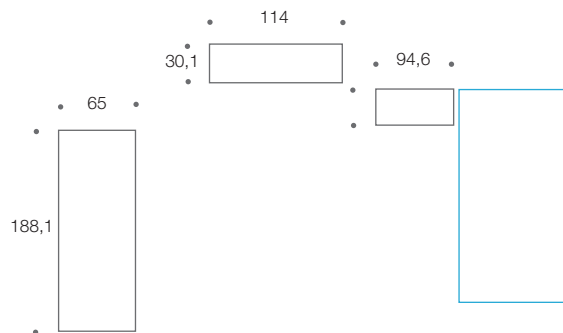

FINITURE - FINISHES (MELAMMINICI / LACCATI)
OLMO NATURALE, BIANCO, TURCHESE.

UN ELEGANTE GIOCO DI NON-COLORI





635

LETTI STYLE + LIBRERIA MASTER / PLUS

C05



STYLE BEDS AND MASTER BOOKCASE





LETTO STYLE

STYLE È UN LETTO-PROGETTO CHE PROPONE DIVERSE CONFIGURAZIONI. UNA GEOMETRICA STRUTTURA A PANNELLO ACCOGLIE MORBIDE FORME IMBOTTITE • STYLE IS A PROJECT-BED THAT ALLOWS TO CREATE DIFFERENT SETTINGS. A GEOMETRIC PANEL STRUCTURE ENVOLVES SOFT UPHOLSTERED SHAPES.

LONGHERONE RIVESTITO IN TESSUTO

IL RIVESTIMENTO DEL LONGHERONE IN TESSUTO DÀ UN TOCCO DI ELEGANZA E CONTRIBUISCE A PERSONALIZZARE OGNI SINGOLA PROPOSTA • THE SIDES' FABRIC COVERING GIVES AN ELEGANT TOUCH AND CONTRIBUTES TO CUSTOMIZE EVERY SINGLE SET.

CASSETTONE ESTRAIBILE

IL CAPIENTE CASSETTONE ESTRAIBILE È IL CONTENITORE IDEALE PER IL CORREDO TESSILE E I GIOCHI • THE LARGE BIG EXTRACTRABLE DRAWER IS THE IDEAL STORAGE PLACE FOR BED LINENS AND TOYS.

LIBRERIA MASTER

LA LIBRERIA MASTER GRAZIE ALLA SUA MODULARITÀ SI ADATTA AD OGNI TIPO DI PROGETTO E DI SPAZIO. DALLE COMPOSIZIONI MINIMALI FINO ALLE GRANDI PARETI • MASTER BOOKCASE ADAPTS TO EVERY KIND OF DESIGN AND SPACE THANKS TO ITS MODULARITY.

LA SCRIVANIA A CENTRO STANZA

UNA SCRIVANIA FREE STANDING È IL COMPLEMENTO IDEALE PER UNO SPAZIO INFORMALE DA VIVERE PIENAMENTE • A FREE STANDING DESK IS THE IDEAL ACCESSORY FOR AN INFORMAL AREA TO LIVE FULLY.



636

LA LIBRERIA COME DIVISORIO



THE BOOKSHELF AS A DIVIDER

LA LIBRERIA MASTER PUÒ ESSERE UTILIZZATA COME DIVISORIO PER DIVIDERE AMBIENTI. ALLA LIBRERIA È POSSIBILE ACCOSTARE LETTI E SCRITTOI PER UNA COMPONIBILITÀ TOTALE... LA SPAZIOSA CABINA XCAB COMPLETA L'ARREDO • THE MASTER BOOKSHELF CAN BE USED AS A DIVIDER TO DIVIDE AMBIENCES. IT IS POSSIBLE TO MATCH BEDS AND DESKS WITH THE BOOKSHELF FOR A TOTAL COMBINABILITY... THE ROOMY XCAB CABIN COMPLETES THE FURNITURE.

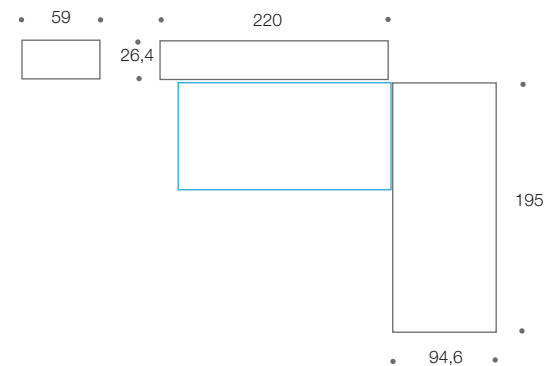

FINITURE - FINISHES (MELAMMINICI / LACCATI)
 BIANCO, ZUCCA, TEXTURE RIGA.



MASTER COMPOSING

GRAZIE AI SUOI MODULI CALIBRATI PER OGNI DESTINAZIONE D'USO IL PROGRAMMA MASTER DA VITA A COMPOSIZIONI FUNZIONALI. MASTER SI ADATTA ANCHE A PICCOLI SPAZI CON UNA RAFFINATA ELEGANZA DI FORME E COLORI • THANKS TO ITS MODULES, BALANCED FOR EVERY USE, THE MASTER PROGRAM CREATES FUNCTIONAL COMPOSITIONS. MASTER ADJUSTS ALSO IN LITTLE SPACES WITH REFINED ELEGANCE OF SHAPES AND COLORS.

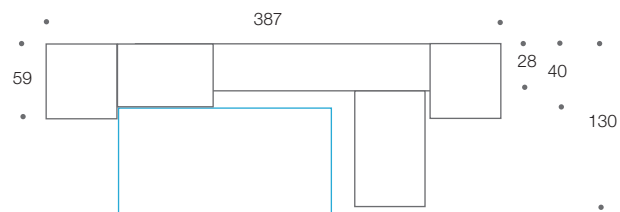

FINITURE - FINISHES (MELAMMINICI / LACCATI)
 OLMO PERLA, ORIENTE, ALABASTRO, AVIO, PRUSSIA, GRIGIO SCURO,
 GRIGIO CHIARO, PISTACCHIO, TEXTURE RIGA.





637

637



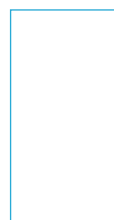
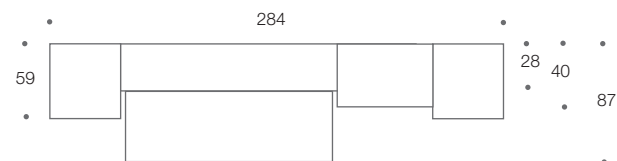
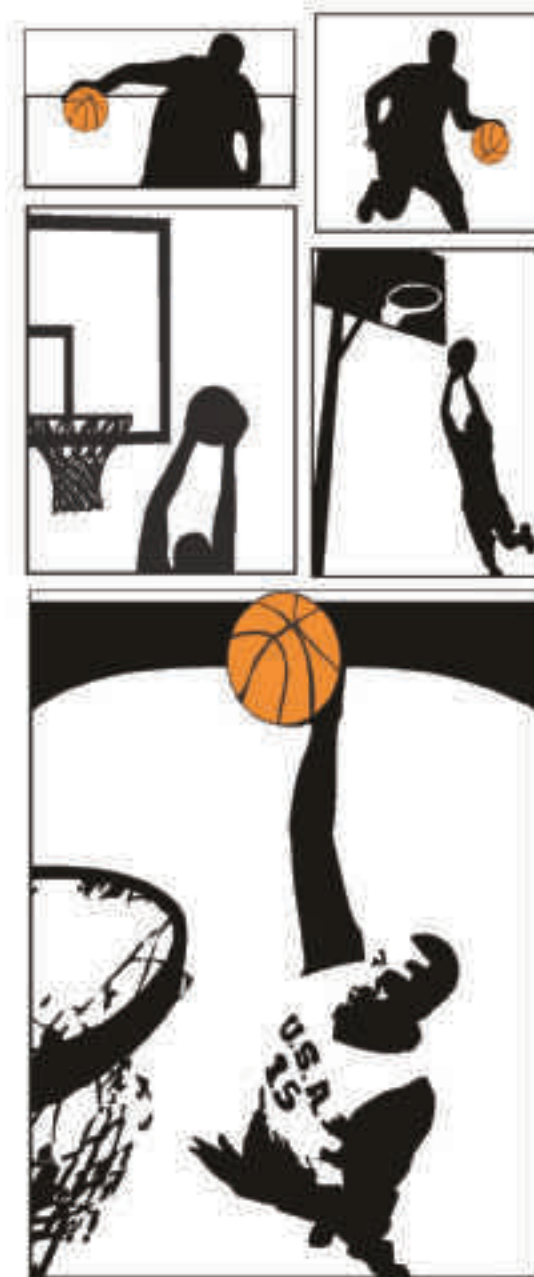

FINITURE - FINISHES (MELAMMINICI / LACCATI)
 OLMO PERLA, OLMO CENERE, ALABASTRO, AVIO, PRUSSIA, GRIGIO
 SCURO, PETROLIO2, TEXTURE RIGA.







ARMADI AD ANTE BATTENTI + SPACE SAVING

C06

DIELLE, NELLE VERSIONI ANTA BATTENTE, RAPPRESENTA UN PUNTO D'ARRIVO IMPORTANTE NEL PANORAMA DELLE PROPOSTE CONTENITIVE PER L'AREA NOTTE CONTEMPORANEA. UN PROGETTO ARMADIO EVOLUTO, IDEALE PER ARREDARE SPAZI ANCHE ALTERNATIVI E PER TUTTE LE ZONE DI SERVIZIO. UN'ATTENZIONE PARTICOLARE È STATA RIVOLTA AL DESIGN DELLE ANTE CHE PRESENTANO SOLUZIONI TECNOLOGICHE ALL'AVANGUARDIA CHE DETERMINANO SOLUZIONI ESTETICHE CON UNA FORTE PERSONALITÀ DISTINTIVA • DIELLE, IN THE VERSION WITH HINGED DOORS, REPRESENTS AN IMPORTANT FINAL POINT IN THE RANGE OF CONTAINMENT PROPOSALS FOR THE CONTEMPORARY NIGHT AREA. AN ADVANCED WARDROBE PROJECT, IDEAL TO FURNISH SPACES ALSO ALTERNATIVE AND FOR ALL THE SERVICE AREAS. A PARTICULAR ATTENTION HAS BEEN PAID TO THE DESIGN OF THE DOORS HAVING TECHNOLOGICAL ADVANDES SOLUTIONS. AESTHETIC SOLUTIONS WITH A STRONG DISTINCTIVE PERSONALITY.

HINGED DOORS WARDROBES + SPACE SAVING



638



UN RAFFINATO GIOCO GRAFICO

AN ELEGANT GRAPHIC GAME



LA TEXTURE TRATTI

SULLE ANTE DIAGONALI L'ORIGINALE GRAFICA DELLA TEXTURE TRATTI VALORIZZA L'ARMADIO DOTATO DI TERMINALE A GIORNO • THE ORIGINAL GRAPHIC OF THE TRATTI TEXTURE ON SLANTING DOORS ENHANCES THE WARDROBE WITH AN OPEN TERMINAL.

L'ANTA TRAPEZOIDALE

L'INSOLITA FORMA DELL'ANTA TRAPEZOIDALE CONFERISCE ALL'AMBIENTE ORIGINALITÀ E PERSONALITÀ DISTINTIVA • THE UNUSUAL SHAPE OF THE TRAPEZIUM-SHAPED DOOR GIVES ORIGINALITY AND CHARACTER TO THE SPACE.

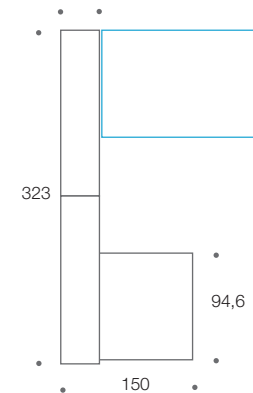

FINITURE - FINISHES (MELAMMINICI / LACCATI)
BIANCO, PETROLIO2, ORIENTE, TEXTURE TRATTO.

ATTUALITÀ DELLE TEXTURE

LA TEXTURE CARBONCINO

OGNI ARMADIO PUÒ ESSERE VALORIZZATO DALLE TEXTURE DIELLE...
LE ANTE, SPESSO ANONIME, DIVENTANO COSÌ SUPERFICI CREATIVE •
EVERY WARDROBE CAN BE ENHANCED WITH DIELLE TEXTURES... IN
THIS WAY FEATURELESS DOORS BECOME CREATIVE SURFACES.

LE MANIGLIE CROMATICHE

IL GIOCO GRAFICO DELLE MANIGLIE È ANCH'ESSO UN SEGNO
IMPORTANTE CHE SOTTOLINEA L'ATTENZIONE AL PARTICOLARE •
ALSO THE GRAPHIC GAME OF HANDLES IS AN IMPORTANT ELEMENT
THAT HIGHLIGHTS THE DETAIL.







SLANTING DOORS: TEXTURES, STICKERS AND HANDLES

IL SISTEMA CROMATICO CONSENTE DI PERSONALIZZARE L'AMBIENTE CON COLORI LACCATI E FINITURE MELAMMINICO DALLE CALDE TONALITÀ DEL LEGNO. ANCHE I TESSUTI DI RIVESTIMENTO E I COORDINATI TESSILI CONTRIBUISCONO AD UN PLANNING GIOVANE E "FRESCO" • THE COLOUR SYSTEM PERMITS PERSONALISING THE ENVIRONMENT WITH LACQUERED COLOURS AND MELAMINE FINISHES WITH WARM WOOD SHADES. THE UPHOLSTERY FABRICS AND THE COORDINATED TEXTILES ALSO CONTRIBUTE TO YOUNG AND "FRESH" PLANNING.







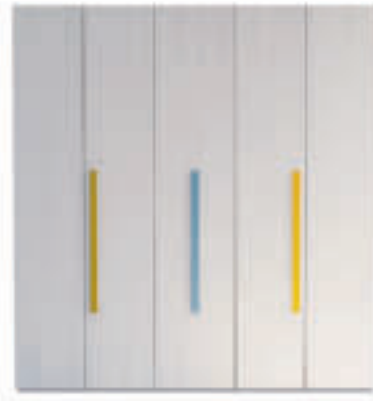

LA FACCIATA DECORATIVA



THE ORNAMENTAL FACADE

SIA PER LE VERSIONI DI ARMADIO AD ANTE SCORREVOLI O BATTENTI È POSSIBILE PERSONALIZZARE GLI ELEMENTI A CONTENERE CON MANIGLIE, TEXTURE, CROMATISMI E TIPOLOGIE DI ANTE CHE VALORIZZANO IL PROGETTO D'INTERIOR DESIGN • BOTH FOR THE SLIDING AND SHUTTER DOOR WARDROBE VERSIONS, IT IS POSSIBLE TO CUSTOMIZE CONTAINING ELEMENTS WITH HANDLES, TEXTURES, SHADES AND TYPES OF DOORS THAT GIVE VALUE TO THE INTERIOR DESIGN PROJECT.

DESIGN IN LIBERTÀ



DESIGN IN FREEDOM



“SAVE” WARDROBE

OLTRE CHE RAPPRESENTARE UNA PRATICA SOLUZIONE SPACE SAVING L'ARMADIO SAVE È UN PROGETTO POLIFUNZIONALE SENZA SOLUZIONE DI CONTINUITÀ, IL TERMINALE ATTREZZATO E LA ZONA STUDIO IN UN UNICUM DI GRANDE FUNZIONALITÀ • “SAVE” WARDROBE IS A PRACTICAL SPACE SAVING SOLUTION AND EVEN A MULTIFUNCTIONAL SEAMLESS PROJECT.

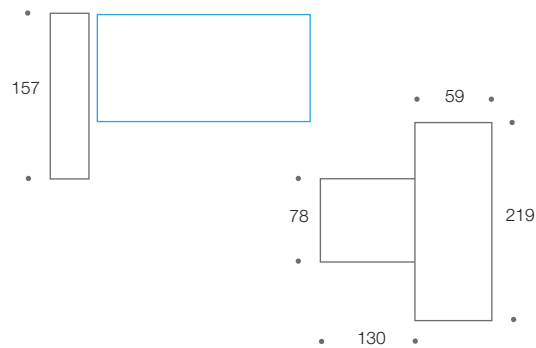
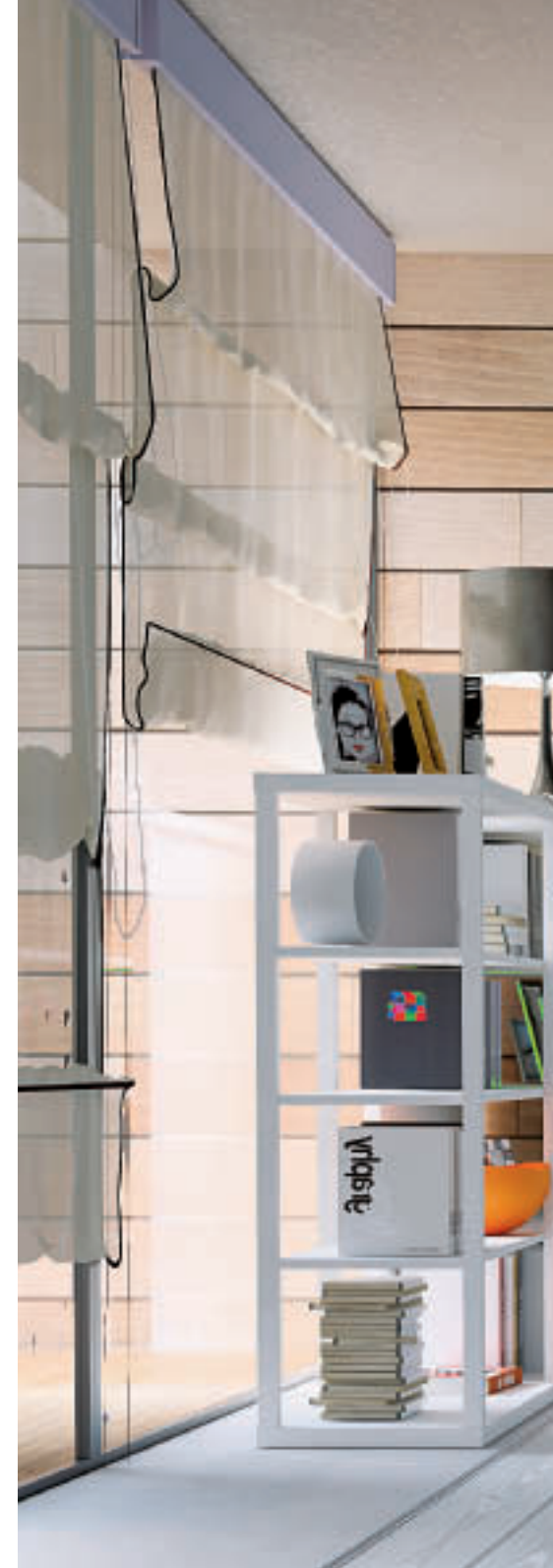

FINITURE - FINISHES (MELAMMINICI / LACCATI)
 OLMO PERLA, OLMO CENERE, BIANCO, SALVIA.



640



“ALADIN” WARDROBE WITH DESK

LA PERFETTA INEGRAZIONE TRA SISTEMI E COMPLEMENTI DÀ VITA A COMPOSIZIONI ARMADI PARTICOLARMENTE INGEGNOSE E RAPPRESENTATIVE CHE CONSENTONO DI OTTIMIZZARE SPAZIO E FUNZIONI • THE PERFET INTEGRATION BETWEEN SYSTEMS AND FURNISHING UNITS WHICH GIVE RISE TO VERY REPRESENTATIVE AND INGENIOUS WARDROBE COMPOSITIONS, OPTIMISING SPACE AND FUNCTIONS.

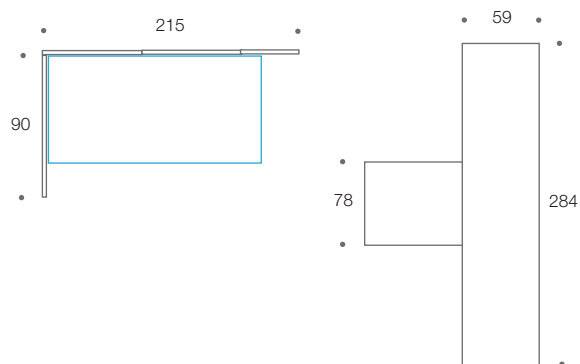

FINITURE - FINISHES (MELAMMINICI / LACCATI)
 BIANCO, GRIGIO SCURO, TEXTURE CARBONCINO,
 PANNELLI SOLUTION.

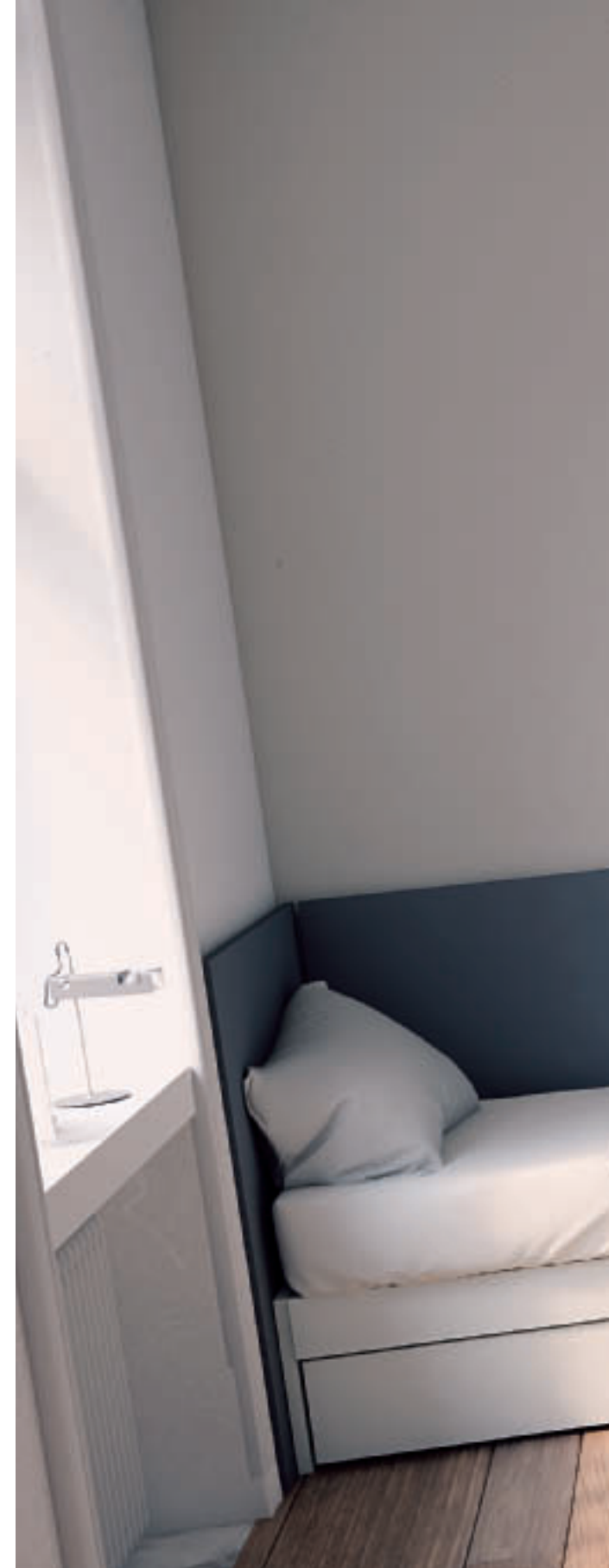



640



“ALADIN TECNO” WARDROBE

GLI ELEMENTI DELLE COLONNEVIP SONO ATTREZZATI CON ANTEVANI E CASSETTI CHE POSSONO INTEGRARSI IN UNA IDEALE ZONA STUDIO PERSONALIZZABILE CON LE FINITURE DIELE • THE ELEMENTS OF THE VIP COLUMNS ARE EQUIPPED WITH DOORS, OPEN COMPARTMENTS AND DRAWERS THOSE CAN BE INTEGRATED IN AN IDEAL STUDY AREA THAT CAN BE CUSTOMIZED WITH ALL DIELE'S FINISHES.

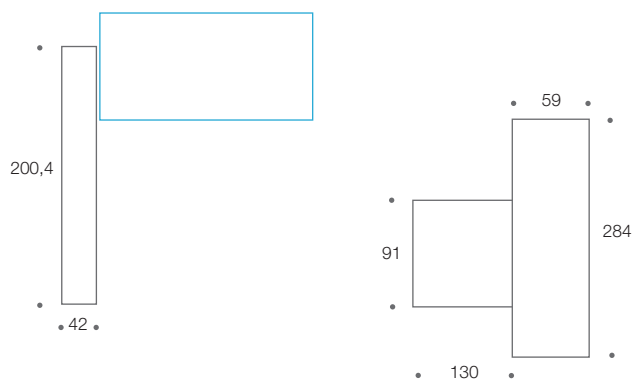

FINITURE - FINISHES (MELAMMINICI / LACCATI)
OLMO PERLA, BIANCO, GRIGIO SCURO, CRETA, SENAPE.



641

ARMADI: SAVE, ALADIN E TECNO

ARMADIO SAVE

GLI ARMADI SAVE SONO CONTENITORI SALVASPAZIO. GRAZIE ALLE ANTE FISSE ED ALLE APERTURE DELLE ANTE PARZIALI, POSSONO INTEGRARSI CON I COMPLEMENTI DI SISTEMA. • "SAVE" WARDROBES ARE SPACE SAVING STORAGE UNITS. THANKS TO THE FIXED DOORS AND THE PARTIAL OPENING DOORS, THEY CAN INTEGRATE WITH THE OTHER ELEMENTS OF THE SYSTEM.

ARMADIO ALADIN

AGLI ARMADI ALADIN SI ACCOSTANO LETTI SINGOLI E MATRIMONIALI E PERFINO SCRITTOI CON VANI COLONNA LATERALI DI SERVIZIO. • "ALADIN" WARDROBES CAN BE COMBINED WITH SINGLE AND DOUBLE BEDS AND EVEN DESKS WITH SIDE SERVICE STORAGE COLUMNS.

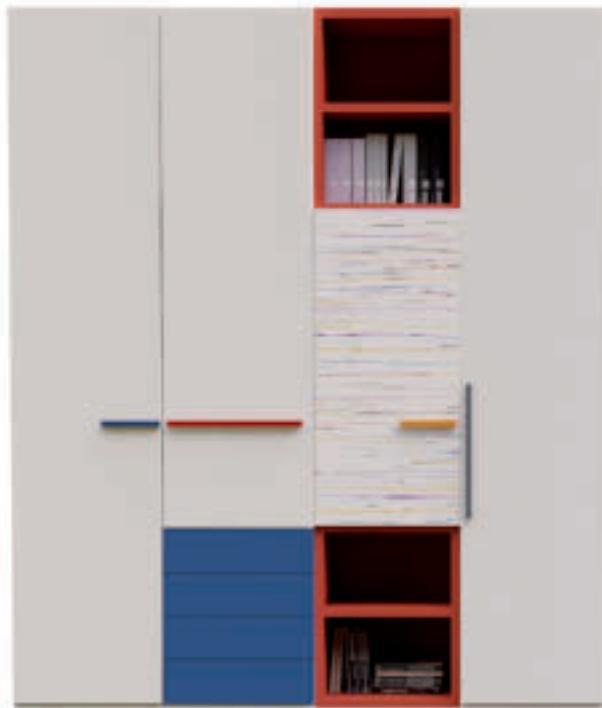

ARMADIO ALADIN TECNO

GLI ARMADI ALADIN TECNO PRESENTANO DELLE COLONNE ATTREZZATE CON ANTE, VANI E CASSETTI ALLE QUALI COLLEGARE DIRETTAMENTE SCRIVANIE E LETTI • "ALADIN TECNO" WARDROBES PRESENTS COLUMN MODULES EQUIPPED WITH DOORS, OPEN STORAGE COMPARTMENTS AND DRAWERS, TO WHICH DIRECTLY PLACE AGAINST DESKS AND BEDS.



INTEGRAZIONE TRA ARMADIO E LIBRERIA



ELEMENTI MASTER E ARMADI

LE COLONNE MASTER UNITAMENTE ALLE SOLUZIONI SCRIVANIA INTEGRATE ESALTANO LA CAPACITÀ COMPOSITIVA DEGLI ELEMENTI A CONTENERE • MASTER COLUMNS TOGETHER WITH INTEGRATED DESK SOLUTIONS ENHANCE THE COMPOSING CAPACITY OF THE CONTAINING ELEMENTS.

L'ARMADIO SPECIALIZZATO

PER LA CAMERETTA IDEALE È PROPOSTO L'ARMADIO SPECIALIZZATO CON PIÙ FUNZIONI PER L'HABITAT CONTEMPORANEO • FOR THE IDEAL CHILDREN BEDROOM IT IS PROPOSED THE SPECIALIZED WARDROBE WITH MORE FUNCTIONS FOR THE CONTEMPORARY HABITAT.



FINITURE - FINISHES (MELAMMINICI / LACCATI)
OLMO PERLA, GRIGIO CHIARO, GRIGIO SCURO, MAGNOLIA.

INTEGRATION OF THE WARDROBE AND THE BOOKSHELF





642

643



INTEGRAZIONE: ARMADI, ZONA STUDIO E SCRIVANIA



INTEGRATION: WARDROBES, STUDYING AREA AND DESK

IL LETTO TIMELESS

TIMELESS È UN LETTO ESSENZIALE DOTATO DI TESTIERA A PANNELLO SAGOMATO ASSOCIATO A UN GIROLETTO IN MASSELLO, SEMPLICE E RIGOROSO NELL'ESPRESSIONE FORMALE • "TIMELESS" IS AN ESSENTIAL BED WITH A SHAPED PANEL HEADBOARD ASSOCIATED WITH A SOLID WOOD BEDFRAME; SIMPLE AND UNBENDING IN FORMAL EXPRESSION.

LA SCRIVANIA A PENISOLA NEL VANO ARMADIO

LA PERFETTA INTEGRAZIONE DEI SISTEMI DIELLE CONSENTE LA FORMAZIONE DI COMPOSIZIONI INEDITE E FUNZIONALI COME LA ZONA STUDIO INTEGRATA • THE PERFECT INTEGRATION OF DIELLE SYSTEMS ALLOWS THE FORMATION OF UNIQUE AND FUNCTIONAL COMPOSITIONS SUCH AS THE INTEGRATED STUDYING AREA.

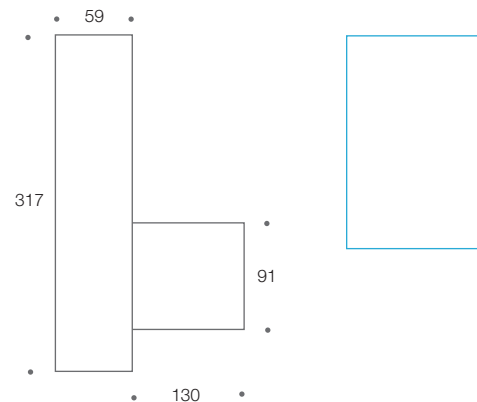

FINITURE - FINISHES (MELAMMINICI / LACCATI)
OLMO NATURALE, BIANCO.



BRIDGE WITH INTEGRATED STUDYING AREA

LA GRANDE SCRIVANIA SOTTOPONTE

SOTTOPONTE UNA SPAZIOSA SCRIVANIA A MISURA SI INSERISCE PERFETTAMENTE NELLA COMPOSIZIONE A PARETE • A ROOMY MANAGEABLE DESK IS PERFECTLY INCLUDED IN THE WALL COMPOSITION.

TERMINALE A LIBRERIA

PALO ALTO INTERPRETA IL TERMINALE LIBRERIA CON SEMPLICITÀ ED ELEGANZA FORMALE... IDEALE SERVIZIO ALLA ZONA STUDIO • PALO ALTO INTERPRETS THE ENDING BOOKSHELF WITH FORMAL SIMPLICITY AND ELEGANCE... PERFECT SERVICE TO THE STUDYING AREA.

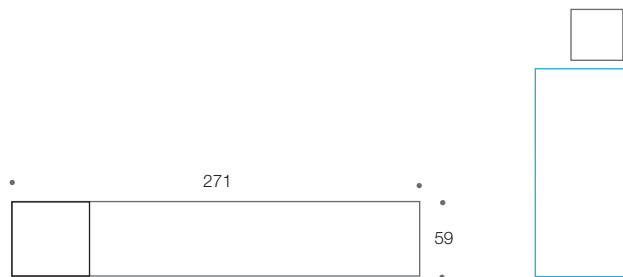



644

645



HIDING DESK



SCRITTOIO A SCOMPARSA

XCAB CABINA ARMADIO

LA CABINA ARMADIO XCAB CONSENTE DI ACCOSTARE TERMINALI LIBRERIA PALO ALTO, IL LETTO CONTAINER E IL PRATICO SCRITTOIO RICHIUDIBILE PER L'OTTIMIZZAZIONE DELLO SPAZIO • THE XCAB WARDROBE CAB ALLOWS TO CONNECT PALO ALTO ENDING BOOKCASES, THE BED CONTAINER AND THE PRACTICAL CLOSEABLE DESK TO OPTIMIZE THE SPACE.

LETTO CONTAINER

IL PIANO DEL LETTO CONTAINER È FACILMENTE APRIBILE E RICHIUDIBILE GRAZIE ALLE MOLLE A GAS DI CUI È DOTATO • THE BASE OF THE BED CONTAINER IS EASILY OPENABLE AND CLOSEABLE THANKS TO THE EQUIPPED GAS SPRINGS.

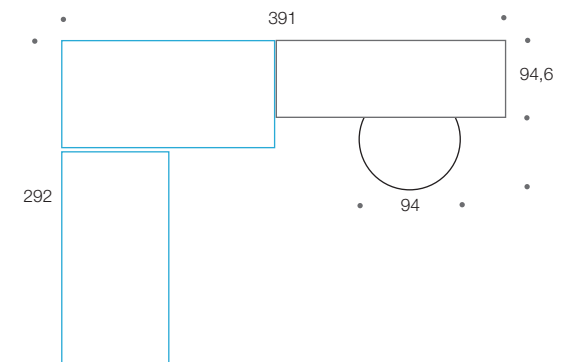

FINITURE - FINISHES (MELAMMINICI / LACCATI)
OLMO PERLA, OLMO NATURALE, ROSA, CORDA2.

SOLUZIONI PER SCRITTOIO A RIBALTA

ARMADIO POLIFUNZIONALE

L'INTEGRAZIONE TRA I SISTEMI ED I COMPLEMENTI DESIGN APPOSITAMENTE STUDIATI CONSENTONO LA FORMAZIONE DI COMPOSIZIONI POLIFUNZIONALI ORIGINALI • THE INTEGRATION BETWEEN SYSTEMS AND SPECIFICALLY DESIGNED COMPLEMENTS ALLOW THE FORMATION OF MULTIFUNCTIONAL ORIGINAL COMPOSITIONS.

LA COLONNA DI SERVIZIO

LA COLONNA MASTER INSERITA TRA GLI ELEMENTI ARMADIO AUMENTA LA VERSATILITÀ DELL'ARMADIO DI SERVIZIO • THE MASTER COLUMN AMONG THE WARDROBE ELEMENTS INCREASES THE VERSATILITY OF THE SERVICE WARDROBE.

LA LIBRERIA MASTER

MASTER È UNA LIBRERIA MULTIFUNZIONE CHE CONSENTE LA FORMAZIONE DI COMPOSIZIONI IMPORTANTI DI FORTE PERSONALITÀ • MASTER IS A MULTIFUNCTIONAL BOOKCASE THAT ALLOWS TO CREATE IMPORTANT COMPOSITIONS WITH A STRONG PERSONALITY.



SCRITTOIO A RIBALTA

UN'ALTRA SCRIVANIA SALVASPAZIO INTEGRATA NEGLI ELEMENTI A CONTENERE SI RENDE IMMEDIATAMENTE DISPONIBILE PER LO STUDIO E IL GIOCO • ANOTHER SPACE SAVING DESK INTEGRATED IN THE STORAGE ELEMENTS, QUICKLY AVAILABLE TO STUDY AND PLAY.

SPACE SAVING

CON UN SEMPLICE GESTO, UN OGGETTO DINAMICO, DA ELEMENTO DECORATIVO SI TRASFORMA IN UN PRATICO SCRITTOIO • WITH A SIMPLE GESTURE, A DYNAMIC OBJECT TURNS FROM A DECORATIVE ELEMENT TO A PRACTICAL DESK.



646



INTEGRAZIONE: ARMADIO E VANO TV RACK



VANO TV RACK INTEGRATO

DISPORRE DI UN VANO TV RACK INTEGRATO DEDICATO ALL'AREA RAGAZZI... UN'ESPERIENZA COINVOLGENTE • HAVING A TV RACK COMPARTMENT INTEGRATED FOR THE KIDS AREA... A CAPTIVATING EXPERIENCE.

IL VANO LIBRERIA

ANCHE UN SEMPLICE VANO A GIORNO PUÒ RISULTARE MOLTO PRATICO PER RIPORRE I LIBRI E I DISPOSITIVI MOBILE • ALSO A PLAIN OPEN COMPARTMENT CAN BE A LOT PRACTICAL TO PUT DOWN BOOKS AND MOBILE DEVICES.

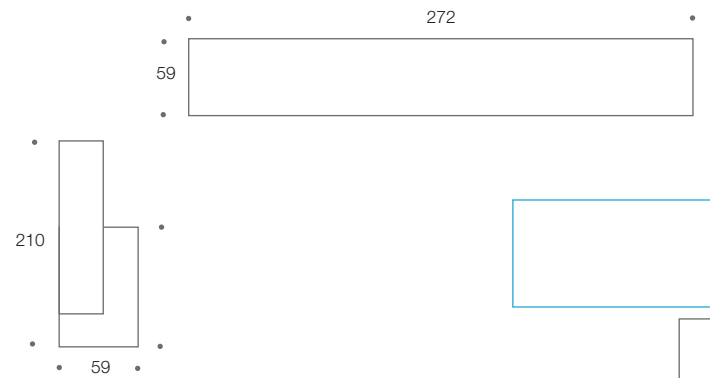

FINITURE - FINISHES (MELAMMINICI / LACCATI)
BIANCO, GRIGIO CHIARO, GRIGIO SCURO, GLICINE, SENAPE.

IL VANO TV ORIENTABILE

TV RACK ORIENTABILE

IL TV RACK ORIENTABILE SEGUE LO SGUARDO, È UNA SOLUZIONE SEMPLICE MA ESTREMAMENTE FUZIONALE PER L'AREA NOTTE • THE ADJUSTABLE TV RACK FOLLOWS THE GAZE, IT IS A SIMPLE BUT EXTREMELY FUNCTIONAL SOLUTION FOR THE NIGHT AREA.

LA ZONA STUDIO ESSENZIALE

POCHI BILANCIATI ELEMENTI COMPONGONO LA ZONA STUDIO IN UN'ARMONIA DI FORME E COLORI • A FEW BALANCED ELEMENTS PUT TOGETHER THE STUDYING AREA IN A BALANCE OF SHAPES AND COLORS.







ARMADI AD ANTE SCORREVOLI

C07

DIELLE RIDISEGNA IL CONTENERE PER L'AREA NOTTE, ATTRAVERSO UNA SELEZIONE DI FINITURE E MOTIVI GRAFICI FRESCHI E ATTUALI, DÀ VITA A SOLUZIONI UNICHE, MAI SCONTATE. ANCHE IL TEMA DELLE MANIGLIE DIVENTA ELEMENTO DISTINTIVO E CONTRIBUISCE A DISEGNARE ORIGINALI GEOMETRIE SULLE ANTE, PER UNO STYLING CONTEMPORANEO • DIELE REDESIGNS THE STORAGE UNITS FOR THE NIGHT AREA THROUGH A SELECTION OF FINISHES, FRESH AND CURRENT GRAPHIC MOTIFS, GIVES RISE TO UNIQUE SOLUTIONS, NEVER PREDICTABLE. EVEN THE THEME OF THE HANDLES BECOMES A DISTINCTIVE ELEMENT AND HELPS TO REDESIGN ORIGINAL GEOMETRIES ON DOORS, FOR A CONTEMPORARY STYLING.

SLIDING DOORS WARDROBES





SLIDING DOORS WARDROBE: PLANA DOOR

ANCHE L'ARMADIO AD ANTE SCORREVOLI HA LE MISURE GIUSTE PER OGNI AMBIENTE. LE FINITURE VARIANO DAI LACCATI COLORE INTENSI, ALLE TONALITÀ PIÙ NEUTRE, AL MELAMMINICO ESSENZA DA ACCOSTARE A PIACERE. QUI PROPOSTO ARMADIO CON ANTA PLANA, DISPONIBILE IN LACCATO O NOBILITATO ESSENZA • ALSO THE SLIDING DOOR WARDROBE HAS THE RIGHT DIMENSIONS FOR EVERY AMBIENCE. FINISHES ARE VARIOUS: FROM THE INTENSE COLORED LACQUERED, TO THE MOST NEUTRAL TONES, THE WOODEN FINISH MELAMINE TO BE MATCHED AS YOU LIKE. HERE PROPOSED A WARDROBE WITH PLANA DOORS, AVAILABLE IN COLOURED LACQUERED OR WOODEN FINISH MELAMINE.

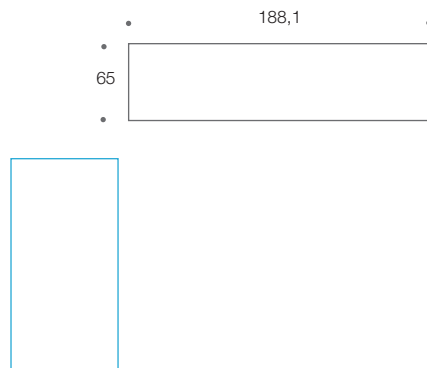

FINITURE - FINISHES (MELAMMINICI / LACCATI)
OLMO NATURALE, OLMO PERLA.





647



SLIDING DOORS WARDROBE IN WOODEN FINISH MELAMINE: LINEAR AND 2 SETTORI DOORS

SI POSSONO ABBINARE LE ANTE SCORREVOLI CON MANIGLIA A PROFILO AI MELAMINICI ESSENZA PIÙ ATTUALI COSÌ COME AI LACCATI COLORE. L'ARMADIO DIELLE AD ANTE SCORREVOLI DIVENTA UN'OCCASIONE DECORATIVA PER L'AMBIENTE FACILMENTE COORDINABILE CON TUTTI GLI ELEMENTI DI SISTEMA E CON LA COLLEZIONE LETTI. LE ANTE LINEAR IN NOBILITATO, CON PROFILO BIANCO O ALLUMINIO, PRESENTANO VENATURA VERTICALE. LE ANTE 2SETTORI OFFRONO INVECE LA POSSIBILITÀ DI ACCOSTARE DIVERSE FINITURE E, SE IN NOBILITATO, PRESENTANO VENA ORIZZONTALE. • IT IS POSSIBLE TO MATCH SLIDING DOORS WITH OUTLINE HANDLE AND THE CURRENT WOODEN FINISH MELAMINE, OR THE COLORED LACQUERED. THE DIELLE SLIDING DOOR WARDROBE IS A DECORATIVE OCCASION FOR THE SPACE AND IT IS EASILY MATCHABLE WITH ALL THE SYSTEM ELEMENTS AND THE BED COLLECTION. LINEAR DOORS IN WOODEN FINISH MELAMINE, WITH WHITE OR ALUMINUM FRAME, HAVE A VERTICAL-ORIENTED WOOD GRAIN. THE 2SETTORI DOORS OFFER THE POSSIBILITY TO MATCH DIFFERENT FINISHINGS AND, WHEN WOODEN FINISH MELAMINE, HAVE AN HORIZONTAL-ORIENTED GRAIN.

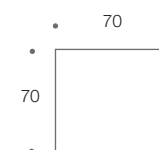
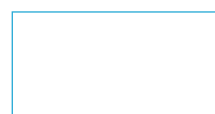

FINITURE - FINISHES (MELAMMINICI / LACCATI)
 OLMO NATURALE, OLMO PERLA, GRIGIO CHIARO, GRIGIO SCURO, CANAPA,
 SENAPE, GIRASOLE.

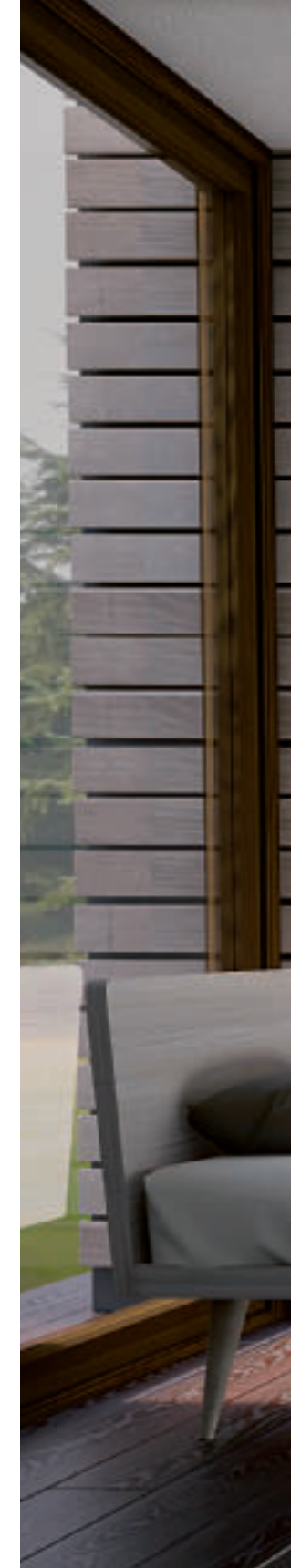



648



THE RIGHT MODULES FOR EVERY SPACE

L'AMPIA POSSIBILITÀ DI SCELTA TRA LE FINITURE DI SISTEMA CONSENTE LA REALIZZAZIONE DI ARMADI A DUE ANTE CON DIFFERENTI SETTORI: LACCATI, CON TEXTURE O NOBILITATO ESSENZA... PER ADEGUARSI AD OGNI PROGETTO D'INTERIOR DESIGN • THE WIDE SELECTION AMONG THE SYSTEM FINISHES ALLOWS THE REALIZATION OF TWO DOORS WARDROBES WITH DIFFERENT SECTORS: LACQUERED, WITH TEXTURE OR WOODEN FINISH MELAMINE TO ADAPT TO EVERY INTERIOR DESIGN PROJECT.

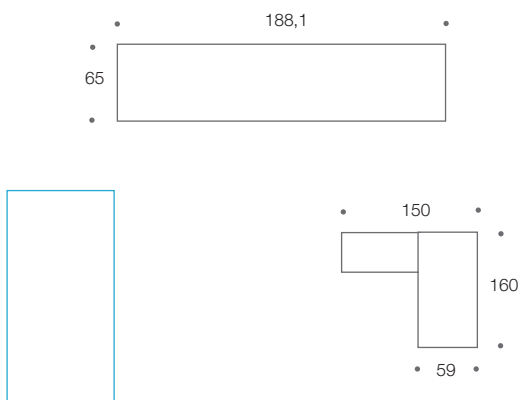

FINITURE - FINISHES (MELAMMINICI / LACCATI)
 CANAPA, MAGNOLIA, CORDA2, PETROLIO2, VERDE PRIMAVERA, BIANCO, GRIGIO SCURO.

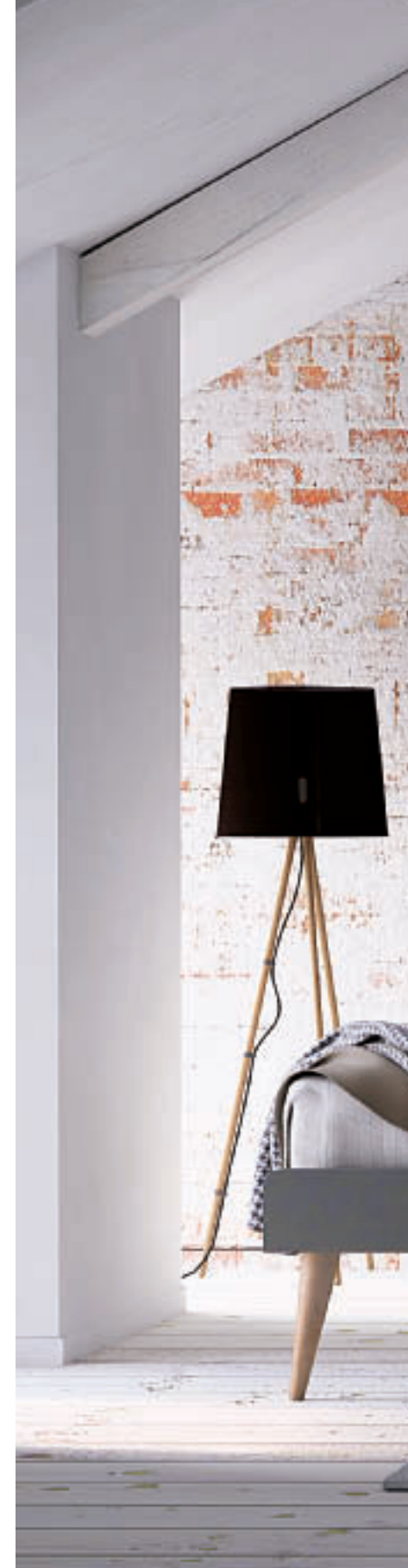



649





PLAYING WITH TEXTURES



GIOCO DI TEXTURE

L'ARMADIO CON LE ANTE DIVISE A SETTORI PERMETTE DI CREARE ATTUALISSIMI GIOCHI DI TEXTURE E CROMATISMI... GIOCANDO CON IL BIANCO E NERO, CON LE TEXTURE OPPURE CON LACCATURE COLORE, CON LE FINITURE DIELE PERSONALIZZARE UN ARMADIO È UN GIOCO ALLA PORTATA DI TUTTI • THE WARDROBE WITH SECTOR DIVIDED DOORS ALLOWS TO CREATE CURRENT PLAYS OF TEXTURE AND SHADES... PLAYING WITH BLACK AND WHITE, WITH TEXTURES OR WITH LACQUERING, WITH DIELE FINISHES, CUSTOMIZING A WARDROBE IS A SUITABLE GAME FOR ALL.

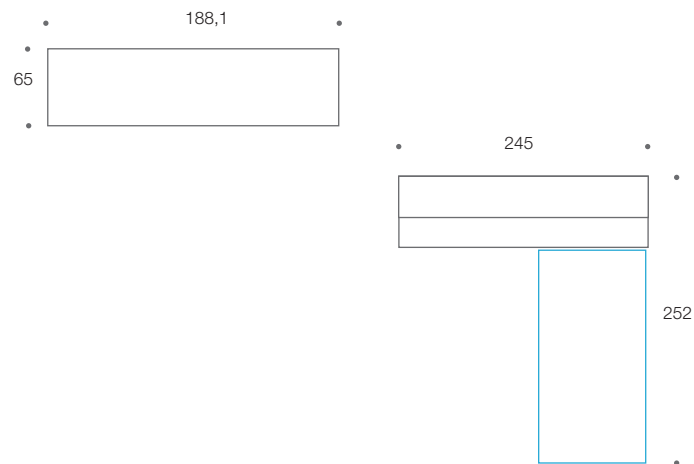

FINITURE - FINISHES (MELAMMINICI / LACCATI)
 BIANCO, GRIGIO SCURO, LAMPONE, TEXTURE RIGA E PUNTO.

PERSONALIZZARE CON LO STICKER



CUSTOMIZING WITH THE STICKER

NELLE CAMERE DEI BAMBINI E DEI RAGAZZI PERSONALIZZARE CON LO STICKER È UN'OPZIONE CREATIVA CHE VALORIZZA OGNI CONTESTO D'ARREDO. NOMI PROPRI DI PERSONA, ILLUSTRAZIONI, DISEGNI AL TRATTO... IN UNA GALLERY PREDEFINITA PROPOSTA DALL'AZIENDA E VICINA ALLA PSICOLOGIA DEI RAGAZZI • CUSTOMIZING WITH THE STICKER IS A CREATIVE OPTION THAT GIVES VALUE TO EVERY FURNITURE CONTEXT IN THE KIDS' ROOM. PROPER PERSONAL NOUNS, ILLUSTRATIONS, HANDMADE DRAWINGS... IN A DEFAULT GALLERY THAT IS PROPOSED BY THE COMPANY AND IS ACCURATE TO THE PSYCHOLOGY OF KIDS.

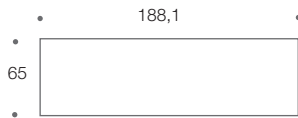

FINITURE - FINISHES (MELAMMINICI / LACCATI)
CANAPA, GRIGIO CHIARO.



650

SIMONE

ANNA



THE SLIDING DOOR'S GRAPHICS

LA NUOVA GRAFICA DELLE ANTE SCORREVOLI CONTEMPLA SOGGETTI ESSENZIALI ED IRONICI. SONO UN TOCCO DI MAGICA ATMOSFERA CHE RALLEGRA, DECORANDO L'AMBIENTE GIOVANE. GLI STICKER INOLTRE SONO FACILMENTE REMOVIBILI • THE NEW GRAPHICS OF THE SLIDING DOORS PORTRAYS ESSENTIAL AND IRONIC SUBJECTS. THEY ARE A HINT OF A MAGICAL, LIGHTENING-UP ATMOSPHERE, DECORATING THE YOUNG AREA. MOREOVER, STICKERS ARE EASILY REMOVABLE.

FINITURE - FINISHES (MELAMMINICI / LACCATI)
GRIGIO SCURO, CANAPA..



651



652



THE TEXTURE CHARACTERIZES THE HABITAT



LA TEXTURE CARATTERIZZA L'HABITAT

ADDIO AL VECCHIO, ANONIMO ARMADIO BIANCO... EWVIVA IL COLORE PERSONALE, MAGARI ASSOCIATO AD UN'ALLEGRA TEXTURE, STUDIATA PER VALORIZZARE GLI SPAZI CONTEMPORANEI. UNA SCELTA DI CARATTERE E STILE IDENTIFICATIVO • FAREWELL TO THE OLD, IMPERSONAL WHITE WARDROBE... HOORAY FOR THE PERSONAL COLOR, MAYBE MATCHED WITH A JOYFUL TEXTURE, DESIGNED TO TAKE ADVANTAGE OF CONTEMPORARY SPACES. A CHOICE OF CHARACTER AND STYLE.

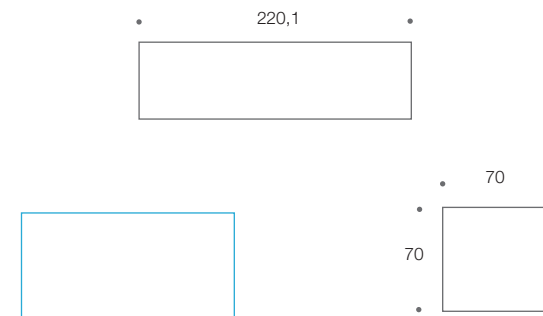

FINITURE - FINISHES (MELAMMINICI / LACCATI)
GRIGIO SCURO, BIANCO, TEXTURE ARLECCHINO..

653

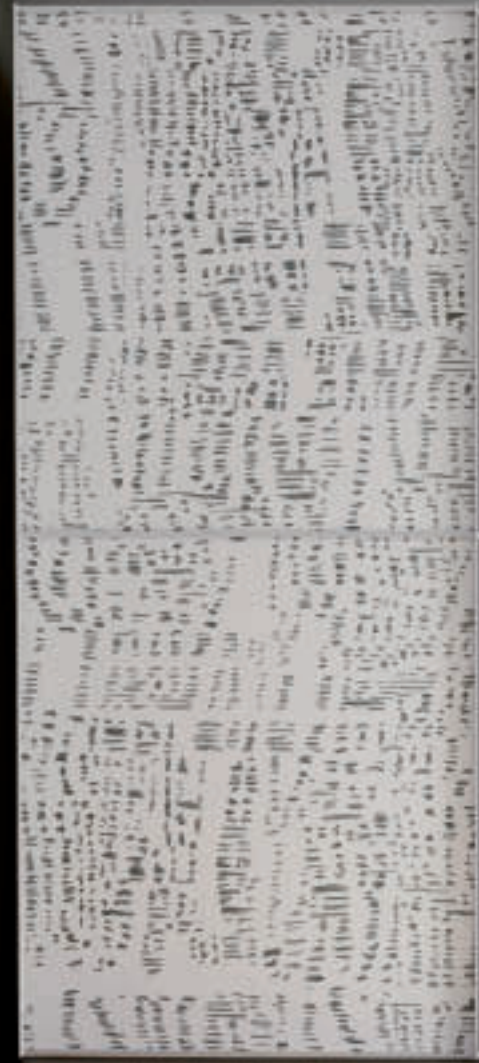



SURFACE DESIGN

IL PROGETTO PERSONALE E DISTINTIVO

IL SISTEMA ARMADI SCORREVOLI DIELE PRESENTA SUPERFICI INNOVATIVE DA UN PUNTO DI VISTA GRAFICO CON SOLUZIONI INEDITE ED ESCLUSIVE • DIELE SLIDING WARDROBE SYSTEM HAS ORIGINAL GRAPHIC SURFACES WITH UNIQUE AND EXCLUSIVE SOLUTIONS.

VISUAL DESIGN

I TEMI DEL GRAPHIC E DEL VISUAL DESIGN SONO ORMAI PARTE INTEGRANTE DEL NOSTRO PANORAMA URBANO E DOMESTICO. DIELE FA SUA QUESTA FILOSOFIA SVILUPPANDO SUPERFICI DI FORTE CARATTERE ESPRESSIVO • THE THEMES OF GRAPHIC AND VISUAL DESIGN ARE PART AND PARCEL OF OUR URBAN AND DOMESTIC OVERVIEW. DIELE CUSTOMIZES THIS PHILOSOPHY DEVELOPING HIGHLY EXPRESSIVE SURFACES.

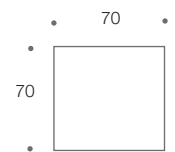
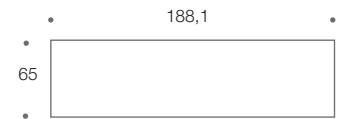

FINITURE - FINISHES (MELAMMINICI / LACCATI)
BIANCO, GRIGIO SCURO, ZUCCA. TEXTURE CARBONCINO.

L'azienda, al fine di migliorare il prodotto, si riserva di apportare senza preavviso le modifiche e le migliorie tecniche ritenute necessarie.

www.dielle.it

DIELLE UTILIZZA MATERIALI
ECO-COMPATIBILI NEL
RISPETTO DELLA NATURA.

DIELLE USES ECO-COMPATIBLE
MATERIALS IN RESPECT FOR NA-
TURE.

I PRODOTTI SONO REALIZZATI
CON MATERIALI E COMPONENTI DI
ALTA QUALITÀ E SONO
GARANTITI 5 ANNI.



5 ANNI
GARANZIA

PRODUCTS ARE MADE WITH
HIGH-QUALITY MATERIALS
AND PARTS AND COME WITH
A 5-YEARS WARRANTY.

I PRODOTTI SONO
INTERAMENTE REALIZZATI
IN ITALIA.

PRODUCTS ARE MADE
ENTIRELY IN ITALY.

R.&D./ DIELLE spa
A.D./ Promark/Comunicazione - MB-
IDEAZIONE/ Giambattista Ciceri
PHOTO/ Punto Zero
ART-BUYER/ Annalia Perego
STAMPA/ Industria Grafica S.I.Z. - VR-

LETTI



DIELLE
GRUPPO DOIMO

DESIGN IN PROGRESS LETTI COLLECTION

<u>4</u>	LETTI STYLE STYLE BEDS
<u>28</u>	LETTI ATTREZZATI EQUIPPED BEDS
<u>56</u>	LETTI COMBINATI COMBINED BEDS
<u>76</u>	LETTO BOSTON BOSTON BED
<u>82</u>	XBED - SISTEMA LETTO XBED - BED SYSTEM
<u>102</u>	LETTI TESSILI TEXTILE BEDS
<u>124</u>	DIVANETTI IMBOTTITI UPHOLSTERED SOFA BEDS
<u>140</u>	LETTI SINGLE - PIAZZA E MEZZO SINGLE BEDS - QUEEN SIZE
<u>154</u>	LETTI A CASTELLO BUNK BEDS
<u>168</u>	PANNELLI A MURO WALL PANELS

DESIGN IN
PROGRESS
LETTI
COLLECTION



LETTI STYLE / STYLE BEDS



4

LETTI ATTREZZATI / EQUIPPED BEDS



28

LETTI COMBINATI / COMBINED BEDS



56

LETTI BOSTON / BOSTON BEDS



76

XBED - SISTEMA LETTO / XBED - BED SYSTEM



82

LETTI TESSILI / TEXTILE BEDS



102

DIVANETTI IMBOTTITI / UPHOLSTERED SOFA BEDS



124

LETTI SINGLE / SINGLE BEDS



140

LETTI A CASTELLO / BUNK BEDS



154

168 PANNELLI A MURO / WALL PANELS



LETTI STYLE IL TUO STILE UNICO... IN TANTE DECLINAZIONI

IL LETTO PROTAGONISTA

ALL'INTERNO DELLO SPAZIO RAGAZZI IL LETTO ASSUME UNA DIMENSIONE DA PROTAGONISTA NEL PROGETTO D'INTERIOR DESIGN • IN THE CHILDREN SPACE THE BED ASSUME A KEY ROLE IN THE PROJECT OF INTERIOR DESIGN.

CREATIVITÀ IN FORME NUOVE

LETTI STYLE È UN SISTEMA LETTO DINAMICO E VITALE DOVE IL DESIGN PROPONE FORME NUOVE TALVOLTA ISPIRATE ALLA CLASSICITÀ MA ANCHE ALL'ESSENZIALITÀ DEL VIVERE CONTEMPORANEO • STYLE BEDS IS A DYNAMIC AND ACTIVE BED SYSTEM IN WHICH THE DESIGN PORPOSES NEW SHAPES, SOMETIMES INSPIRED BY CLASSICAL STYLE, BUT EVEN BY THE SIMPLICITY OF CONTEMPORARY LIVING.



DIELLE
GRUPPO DOIMO

YOUR UNIQUE STYLE... IN VARIOUS CONFIGURATIONS





LETTI STYLE

LE TIPOLOGIE

Cassetto



Miniblock

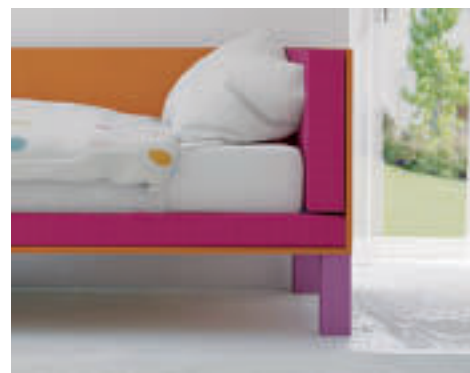

Triangolo



Sfera



Trottola



STYLE È UNA NUOVA COLLEZIONE DIELLE DI LETTI PER RAGAZZI DALLO STILE UNICO E DAL LOOK FRESCO ED ATTUALE. LA RICERCA PROGETTUALE SI BASA SULLA POSSIBILITÀ DI SCEGLIERE LE TIPOLOGIE DI PIEDI-SOSTEGNI CHE NE CARATTERIZZANO IL DESIGN. LA SFERA, IL MINIBLOCK, LA TROTTOLA E IL TRIANGOLO RAPPRESENTANO FORME GEOMETRICHE ESSENZIALI, VICINE ALLA PSICOLOGIA DEI RAGAZZI. INOLTRE SONO PROPOSTE DIFFERENTI E ORIGINALI SOLUZIONI PER LE TESTIERE: IL RICCILO O LE SOLUZIONI PANNELLO/TESSUTO SONO FORME IMBOTTITE E RIVESTITE IN TESSUTO NELLE TONALITÀ CROMATICHE MODA OPPURE IN LEGNO NELLE ESSENZE COORDINATE DI SISTEMA • STYLE IT'S A NEW DIELLE CHILDREN BEDS COLLECTION WITH A UNIQUE STYLE AND A FRESH AND ACTUAL LOOK.THE PROJECT RESEARCH IS BASED ON THE NEED TO SELECT THE TYPES OF FEET-SUPPORT WHICH CHARACTERIZE THE IMAGE.THE SPHERE,THE RECTANGLE,THE SPIN AND THE TRIANGLE REPRESENT ESSENTIAL GEOMETRIC SHAPES, CLOSE TO THE CHILDREN'S PSYCHOLOGY.THEY ARE DIFFERENT PROPOSALS AND ORIGINAL SOLUTIONS FOR THE HEADBOARDS:THE CURL OR THE SOLUTIONS PANEL/FABRICS ARE UPHOLSTERED AND COATED SHAPES IN THE FASHION CHROMATIC SHADES OR IN THE SYSTEM COORDINATED WOOD-FINISHES.

UPHOLSTERED HEADBOARDS “CURL”

LA RAFFINATA ELEGANZA DEL DISEGNO DEL LETTO STYLE, UN GIOCO DI MATERIALI E FINITURE PREZIOSE COME L'ARGENTO, LA TRAMA TESSILE MATERICA, LA TENUE LACCATURA OPACO. MA ANCORA UNA VOLTA, A SORPRENDERE È LA SCELTA DI UN DESIGN DI MEMORIA CHE STRIZZA L'OCCHIO ALL'IDEA DI UNO STILE CLASSICO SENZA TEMPO • THE REFINED ELEGANCE OF THE STYLE BED DESIGN. MATERIALS AND PRECIOUS FINISHES SUCH AS SILVER, MATERIC TEXTILE TEXTURE, SOFT MATT LACQUERING. YET ONE MORE TIME, WHAT CAN SURPRISE IS CHOOSING A MEMORY DESIGN THAT LOOKS TO AN IDEA OF A CLASSIC STYLE AS OLD AS TIME.





TESTIERE IMBOTTITE, LACCATO O ESSENZA

LA COLLEZIONE STYLE PROPONE UNA VASTA GAMMA DI LETTI PROPOSTI NELLE CONFIGURAZIONI PIÙ FUNZIONALI E RAPPRESENTATIVE. ZONA RIPOSO CON LETTO STYLE LACCATO ORIENTE CON GAMBA TROTTOLA IN FINITURA ARGENTATA. GLI ELEMENTI LUDICI CARATTERIZZANO LA PROPOSTA • THE STYLE COLLECTION PROPOSES A WIDE RANGE OF BEDS AVAILABLE IN THE MOST FUNCTIONAL AND REPRESENTATIVE CONFIGURATIONS. RESTING ZONE WITH ORIENTE LACQUERED STYLE BED WITH SILVER FINISHED TROTTOLA LEG. THE PLAYFUL ELEMENTS CHARACTERIZE THE PROPOSAL.



UPHOLSTERED, LACQUERED OR WOOD-FINISH HEADBOARDS





LACCATO CON UN TOCCO TESSILE

SOLUZIONE PONTE CON SISTEMA PALO ALTO, ELEMENTI INTEGRATI
LIBRERIA A GIORNO ATTREZZATA IN LACCATO, LETTI STYLE CON
TESTIERA E PEDIERA LACCATO CON LONGHERONE RIVESTITO IN TESSUTO
SFODERABILE • SOLUTION WITH PALO ALTO SYSTEM, INTEGRATED
ELEMENTS, EQUIPPED OPEN BOOKSHELF IN LACQUERED FINISHES, STYLE
BEDS WHITE LACQUERED WITH PADDED BED-SIDES IN REMOVABLE FABRIC
COATING.

LACQUERED WITH A TEXTILE TOUCH





STYLE BEDS: THE SOFA/BED VERSIONS

LETTI A DIVANETTO, VARIANTE DISPOSIZIONE LETTI STYLE INCROCIATI CON SCRITTOIO INTEGRATO, CON PANNELLI LACCATO E LONGHERONE RIVESTITO IN TESSUTO SFODERABILE • VARIATION WITH CORNER ARRANGED BEDS WITH INTEGRATED DESK, WITH LACQUERED PANELS AND PADDED BED-SIDES IN REMOVABLE FABRIC COATING.





LETTI **STYLE** / CONFIGURAZIONE ANGOLARE

LETTI **STYLE** IN CONFIGURAZIONE ANGOLARE, CON PANNELLI LACCATO E LONGHERONE RIVESTITO IN TESSUTO SFODERABILE • VARIATION WITH CORNER ARRANGED BEDS, WITH LACQUERED PANELS AND PADDED BED-SIDES IN REMOVABLE FABRIC COATING.

STYLE BEDS / CORNER CONFIGURATION

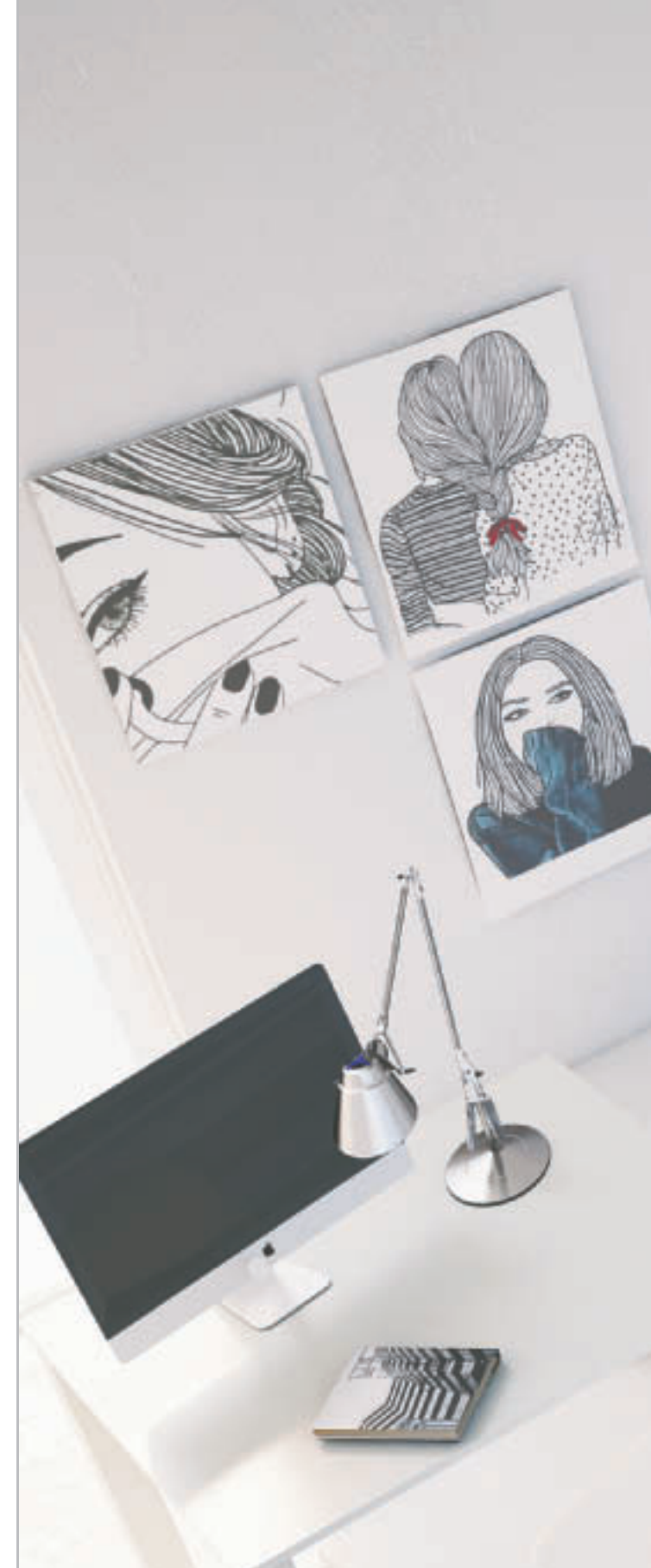





LETTO STYLE - CON CASSETTONE / STYLE BED - WITH DRAWER

TESTIERE IMBOTTITE / STRUTTURA NOBILITATO LEGNO



UN LETTO-PROGETTO CHE PROPONE DIVERSE CONFIGURAZIONI. UNA GEOMETRICA STRUTTURA A PANNELLO ACCOGLIE MORBIDE FORME IMBOTTITE CHE INTERPRETANO IL DESIGN NIGHT&DAY. LE BASI SONO PROPOSTE IN METALLO, CON GAMBE O CON CASSETTONE • A NEW BED-PROJECT THAT PROPOSES DIFFERENT COMBINATIONS. A GEOMETRICAL PANEL STRUCTURE CONTAINS SOFT UPHOLSTERED SHAPES THOSE INTERPRETE NIGHT AND DAY DESIGN. BASES ARE MADE IN METAL, WITH FEETS OR DRAWER.

UPHOLSTERED HEADBOARDS / CARCASE WOOD-FINISH MELAMINE

LETTO STYLE - BASE METALLO / STYLE BED - METAL BASE





LETTO STYLE CON CASSETTO E GAMBA SFERA

STYLE BED WITH DRAWER AND SPHERICAL FEET

LETTO STYLE LACCATO CON GIROLETTO RIVESTITO IN TESSUTO COORDINATO, GAMBA SFERA IN LEGNO. STYLE È UNA NUOVA COLLEZIONE DIELLE DI LETTI PER RAGAZZI DALLO STILE UNICO E DAL LOOK FRESCO ED ATTUALE. LA RICERCA PROGETTUALE SI BASA SULLA POSSIBILITÀ DI SCEGLIERE LE TIPOLOGIE DI PIEDI-SOSTEGNI CHE NE CARATTERIZZANO IL DESIGN • LACQUERED STYLE BED WITH COORDINATED FABRIC COVERED BEDFRAME, RAW SOLID WOOD SPHERICAL FEET. "STYLE" IS A NEW DIELLE BEDS' COLLECTION FOR CHILDREN WITH A UNIQUE STYLE AND WITH A FRESH, CONTEMPORARY LOOK. THE DESIGN CONCEPT IS BASED ON THE POSSIBILITY TO CHOOSE THE SHAPE OF THE FEET-SUPPORTS THOSE CHARCATERIZE THE WHOLE DESIGN OF THE BED.





LETTI STYLE

PIAZZA E MEZZA

STYLE È UNA NUOVA COLLEZIONE DIELLE DI LETTI PER RAGAZZI DALLO STILE UNICO E DAL LOOK FRESCO ED ATTUALE. LA RICERCA PROGETTUALE SI BASA SULLA POSSIBILITÀ DI SCEGLIERE LE TIPOLOGIE DI PIEDI-SOSTEGNI CHE NE CARATTERIZZANO IL DESIGN. LA SFERA, IL MINIBLOCK, LA TROTTOLA E IL TRIANGOLO RAPPRESENTANO FORME GEOMETRICHE ESSENZIALI, VICINE ALLA PSICOLOGIA DEI RAGAZZI. INOLTRE SONO PROPOSTE DIFFERENTI E ORIGINALI SOLUZIONI PER LE TESTIERE: IL RICCIOLO O LE SOLUZIONI PANNELLO/TESSUTO SONO FORME IMBOTTITE E RIVESTITE IN TESSUTO NELLE TONALITÀ CROMATICHE MODA OPPURE IN LEGNO NELLE ESSENZE COORDINATE DI SISTEMA • QUEEN SIZE STYLE BEDS - "STYLE" IS A NEW DIELE BEDS' COLLECTION FOR CHILDREN WITH A UNIQUE STYLE AND WITH A FRESH, CONTEMPORARY LOOK. THE DESIGN CONCEPT IS BASED ON THE POSSIBILITY TO CHOOSE THE SHAPE OF THE FEET-SUPPORTS THOSE CHARACTERIZE THE WHOLE DESIGN OF THE BED. THE SPHERE AND THE "MINIBLOCK", THE "SPINNING TOP" AND THE TRIANGLE REPRESENT ESSENTIAL SHAPES, CLOSE TO THE CHILDREN'S PSYCHOLOGY. DIELE ALSO PROPOSES DIFFERENT AND ORIGINAL HEADBOARDS SOLUTIONS: THE "CURL" OR THE PANEL/TEXTILE SOLUTION ARE UPHOLSTERED SHAPES COVERED IN FABRIC PRESENTED IN CONTEMPORARY LACQUERED CHROMATIC SHADES OR IN MELAMINE ECO-WOOD AS FOR SAMPLES COLLECTION.

Riccio



Miniblock

Tessile



Trottola

Pannello



Sfera



Pannello

TESTIERE IMBOTTITE E NOBILITATO LEGNO

UPHOLSTERED AND WOOD-FINISH MELAMINE HEADBOARDS

LA COLLEZIONE STYLE PROPONE UNA VASTA GAMMA DI LETTI PROPOSTI NELLE CONFIGURAZIONI PIÙ FUNZIONALI E RAPPRESENTATIVE. LA ZONA RIPOSO È CARATTERIZZATA DA ELEMENTI CLASSICI, MA DAL DESIGN CONTEMPORANEO • THE STYLE COLLECTION PROPOSES A WIDE RANGE OF BEDS AVAILABLE IN THE MOST FUNCTIONAL AND REPRESENTATIVE CONFIGURATIONS. THE BEDS COLLECTION IS PROPOSALS WITH CLASSIC AND CONTEMPORARY STYLE.







TESSUTO E NOBILITATO ESSENZA

COLLEZIONE LETTI STYLE. TANTE PROPOSTE PER UNA SCELTA LIBERA CHE SPAZIANO DAL DESIGN PIÙ INNOVATIVO AL CLASSICO SENZA TEMPO. MORBIDE IMBOTTITURE TESSILI DIALOGANO CON IL NOBILITATO ESSENZA E CON LE RAFFINATE LACCATURE OPACO. A CIASCUNO IL GIUSTO MIX • COLLECTION STYLE BEDS. SEVERAL PROPOSALS FOR A FREE CHOICE, FROM THE INNOVATIVE DESIGN TO THE TIMELESS CLASSIC. SOFT TEXTILE PADDINGS DIALOG WITH THE MELAMINE ESSENCES AND THE REFINED MATT VARNISHES. TO EACH HIS OWN MIX TASTE.

TEXTILE AND WOOD-FINISH MELAMINE



LETTI ATTREZZATI POLIFUNZIONALI ARKIMEDE / TWINNY

LETTI & LETTI

LA POSSIBILITÀ DI COMPATTARE I LETTI NELLE CAMERE PER RAGAZZI NON È SOLO UN PLUS DI PROGETTO, MA UNA VERA E PROPRIA ESIGENZA • THE POSSIBILITY TO COMPACT THE BEDS IN CHILDREN'S BEDROOMS IT'S NOT ONLY A DESIGN PLUS, BUT A REAL NEED.

LETTI & FUNZIONI

LA RICERCA PROGETTUALE HA SVILUPPATO SEMPLICI, MA FUNZIONALI SOLUZIONI SPACE SAVING PER L'ARREDO DI PICCOLI SPAZI • DESIGN RESEARCH DEVELOPED SIMPLE BUT FUNCTIONAL SPACE SAVING SOLUTIONS TO DESIGN AND FURNISH SMALL SPACES.

EQUIPPED MULTIFUNCTIONAL BEDS: ARKIMEDE/TWINNY





IL COMPATTO SALVASPAZIO

THE COMPACT SPACE-SAVER



L'ARTE DI MOLTIPLICARE LO SPAZIO OFFRENDO SOLUZIONI POLI-FUNZIONALI DI ALTO VALORE ESTETICO E FORMALE. IN POCHI METRI QUADRATI SI TROVA LO SPAZIO NECESSARIO PER ACCOGLIERE TRE RAGAZZI CON TUTTO IL LORO MONDO IMMEDIATAMENTE DISPONIBILE

- THE ART OF MULTIPLYING SPACE BY PROVIDING MULTIPURPOSE SOLUTIONS OF HIGH AESTHETIC AND FORMAL VALUE. IN A FEW SQUARE METERS IS LOCATED ENOUGH SPACE TO ACCOMMODATE THREE BOYS WITH THEIR WHOLE WORLD IMMEDIATELY AVAILABLE.

ARKIMEDE



3 SLEEPING PLACES - FOR THREE YOUNGSTERS

PER TRE RAGAZZI... TRE POSTI LETTO

I LETTI SCORRONO, SI COMPATTANO, SCOPRENDO FUNZIONI E SPAZI A CONTENERE INATTESI E PREZIOSI COME LA SALITA CONTENITORE, IL CONTAINER, LA CABINA ARMADIO. LE PARTI A GIORNO GARANTISCONO AMPIO SPAZIO PER I LIBRI E L'OGGETTISTICA. • BEDS SLIDE, BECOME COMPACT, RISE BY DISCOVERING FUNCTIONS AND SPACES TO CONTAIN UNEXPECTED AND PRECIOUS THINGS AS THE STORAGE-BOX LADDER, THE CONTAINER, THE WALK-IN CLOSET. THE OPEN UNITS GUARANTEE LARGE SPACE FOR BOOKS AND OBJECTS.



A te che sei il mio grande
AMORE
sei il mio amore grande
A te che hai preso la mia vita
e mi hai fatto molto di più
A te che mi hai dato senso al tempo
SENZA MICHI VEDERE
A te che sei il mio grande
AMORE

ARKIMEDE

DUE METRI QUADRI IN PIÙ. UNA DINAMICA SPACE SAVING



TWO SQ.M. MORE. A SPACE-SAVING DYNAMIC

I LETTI ESTRAIBILI E I PICCOLI CONTENITORI SONO MONTATI SU RUOTE PER FACILI SPOSTAMENTI. QUESTO CONSENTE IN POCHI SECONDI DI CAMBIARE RADICALMENTE LA DISPOSIZIONE DEGLI ELEMENTI CONFIGURANDO LETTI E CONTENITORI A PIACERE. LE PRATICHE MENSOLE SOTTOPONTE OFFRONO UN VALIDO SUPPORTO DI SERVIZIO AI LETTI E ALLO SCRITTOIO. I CROMATISMI RICERCATI E ATTUALI COMPLETANO IL PROGETTO • THE PULLOUT BEDS AND THE SMALL STORAGE BOX UNITS ARE MOUNTED ON CASTORS FOR EASY MOVEMENTS. THIS ALLOWS IN A FEW SECONDS TO CHANGE RADICALLY THE DISPOSITION OF THE ELEMENTS CONFIGURING BEDS AND STORAGE BOX UNITS AT PLEASURE. THE PRACTICAL SHELVES UNDER THE BRIDGE OFFER A VALID SERVICE SUPPORT TO THE BEDS AND THE WRITING DESK. THE REFINED AND CURRENT COLOURS COMPLETE THE DESIGN.





Alessandra

Enrica

ARKIMEDE

COMPLEMENTI DI SERVIZIO AI LETTI

DUE LETTI TROVANO IDEALE COLLOCAZIONE E AL LORO SERVIZIO C'È SPAZIO PER IL CONTENITORE-COMODINO. LA SOVRAPPOSIZIONE DEI LETTI CONSENTE DI RECUPERARE FINO A QUATTRO METRI QUADRATI DI SPAZIO CON UN VANTAGGIO EVIDENTE PER LA LIBERTÀ DI MOVIMENTO NELL'AMBIENTE • TWO BEDS FIND IDEAL LOCATION AND THERE IS SPACE FOR THE STORAGE BEDSIDE TABLE AT THEIR SERVICE. THE OVERLAP OF THE BEDS CAN RECOVER UP TO FOUR SQUARE FEET OF SPACE WITH A CLEAR ADVANTAGE FOR THE FREEDOM OF MOVEMENT IN THE ROOM.



BEDS' SERVICE COMPLEMENTS





Alessandra

Enrica

ARKIMEDE

DISPORRE DELLO SPAZIO... IN LIBERTÀ



IL LETTO INFERIORE ESTRAIBILE SI SPOSTA FACILMENTE CON UN SEMPLICE GESTO. L'ACCESSO AL LETTO ALTO È CONFORTEVOLE ANCHE PER IL RIASSETTO DEL LETTO STESSO. I CAPIENTI ELEMENTI DELLA CABINA ARMADIO INTEGRATA SONO ATTREZZATI E FUNZIONALI • THE LOW PULL-OUT BED CAN BE EASILY MOVED WITH A SIMPLE GESTURE, FREEING THE SPACE FOR THE LADDER-STORAGE UNIT. ACCESS TO THE TOP BED IS CONVENIENT, INCLUDING TO MAKE IT UP. THE CAPACIOUS ELEMENTS OF THE WALK-IN CLOSET ARE EQUIPPED AND FUNCTIONAL.

HAVING FREE SPACE... IN FREEDOM







SPORTS DESTINATION
FOOTBALL



ARKIMEDE

LA PERFETTA INTEGRAZIONE ARKIMEDE/SISTEMI

A PERFECT INTEGRATION ARKIMEDE/SYSTEMS



RECUPERARE DUE METRI QUADRATI DI SPAZIO È FACILE CON IL LETTO A SOPPALCO INCORPORATO NELLA COMPOSIZIONE. I LETTI SI RENDONO IMMEDIATAMENTE DISPONIBILI PER IL RIPOSO. LO SPAZIO NON È PIÙ UN PROBLEMA! • RECOVERING TWO SQUARE METRES OF SPACE IS EASY WITH THE LOFT BED INTEGRATED IN THE COMPOSITION. THE BEDS BECOME IMMEDIATELY AVAILABLE FOR SLEEPING. SPACE IS NO LONGER A PROBLEM!



Luca

Marta

ARKIMEDE

DOPPIO LETTO + FUNZIONI

DOUBLE BED + FUNCTIONS



RECUPERARE DUE METRI QUADRATI DI SPAZIO È FACILE CON IL LETTO A SOPPALCO INCORPORATO NELLA COMPOSIZIONE. I LETTI SI RENDONO IMMEDIATAMENTE DISPONIBILI PER IL RIPOSO. LO SPAZIO NON È PIÙ UN PROBLEMA! • RECOVERING TWO SQUARE METRES OF SPACE IS EASY WITH THE LOFT BED INTEGRATED IN THE COMPOSITION. THE BEDS BECOME IMMEDIATELY AVAILABLE FOR SLEEPING. SPACE IS NO LONGER A PROBLEM!

ARKIMEDE

LA SERIE ARKIMEDE SI CARATTERIZZA PER LA COMPLETEZZA. SI POSSONO SCEGLIERE 4 MODELLI DIVERSI PER ALTEZZA: 58 - 74 - 87 - 103 CM. SI POSSONO AVERE VARI TIPI DI LETTO INFERIORE: CON 4 O 6 CASSETTI, CON 2 CASSETTONI, CON 2 CASSETTI E 2 CASSETTONI, O ADDIRITTURA CON UN ULTERIORE LETTO A SCOMPARSO. IL LETTO SUPERIORE PUO' ESSERE ATTREZZATO CON 2 CASSETTI, OPPURE CON 1 O 2 SCRIVANIE ESTRAIBILI. AL LETTO SUPERIORE E' POSSIBILE AGGANCIARE LA PROTEZIONE RECLINABILE E LA SCALETTA REMOVIBILE. • THE ARKIMEDE SERIES STANDS OUT IN TERMS OF ITS COMPLETENESS. 4 MODELS CAN BE CHOSEN, DIFFERENT IN TERMS OF HEIGHT: 58 - 74 - 87 - 103 CM. VARIOUS TYPES OF BOTTOM BED ARE AVAILABLE: WITH 4 OR 6 DRAWERS, WITH TWO LARGE DRAWERS, WITH 2 DRAWERS AND 2 LARGE DRAWERS, OR EVEN WITH AN ADDITIONAL PULL-OUT BED. THE TOP BED CAN BE EQUIPPED WITH 2 DRAWERS, OR WITH 1 OR 2 PULL-OUT WRITING DESKS. THE RECLINING GUARD AND REMOVABLE LADDER CAN BE FASTENED TO THE TOP BED.

LETTI SINGOLI PER MATERASSO DA 80 CM.

H.58 - P.89,5 - L. 204/203

LETTO SINGOLO

SINGLE BED



L. 204/203 H. 58 P. 89,5

**SINGLE BEDS
FOR MATTRESSES OF 80 CM.**

CON 4 CASSETTI

WITH 4 DRAWERS



**SINGLE BEDS
FOR MATTRESSES OF 80/90 CM.**

CON 2 CASSETTONI

WITH 2 DEEP DRAWERS



**SINGLE BEDS
FOR MATTRESSES OF 80/90 CM.**

H.58 - P.89,5 - L. 204/203
CON SECONDO LETTO ESTRAIBILE

WITH SECOND PULL-OUT BED



**SINGLE BEDS
FOR MATTRESSES OF 80 CM.**

H.74 - P.89,5 - L. 204/203
LETTO SINGOLO

SINGLE BED



L. 204/203 H. 74 P. 89,5

**SINGLE BEDS
FOR MATTRESSES OF 80 CM.**

CON 6 CASSETTI

WITH 6 DRAWERS

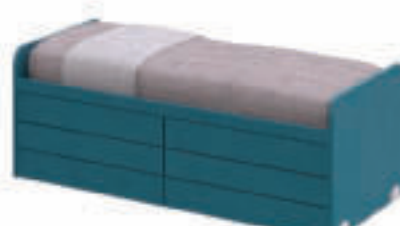

**SINGLE BEDS
FOR MATTRESSES OF 80/90 CM.**

CON 2 CASSETTI E SECONDO LETTO ESTRAIBILE

WITH 2 DRAWERS AND
SECOND PULL-OUT BED





ARKIMEDE

LE VERSIONI AD ALTEZZA 87 E 103 CM. POSSONO ACCOGLIERE UN LETTO INFERIORE SCORREVOLE ATTREZZATO E TOTALMENTE INDIPENDENTE. OLTRE AGLI SPAZIOSI CASSETTI E CASSETTONI UN TERZO LETTO ESTRAIBILE PUÒ ESSERE RESO COMODAMENTE DISPONIBILE TRAMITE IL VANO SOTTOSTANTE. TUTTI I LETTI DELLA SERIE ARKIMEDE SONO RIFINIBILI IN TUTTE LE LACCATURE E I MELAMMINICI ESSENZA. •VERSIONS WITH HEIGHT 87 AND 103 CM CAN HAVE A LOWER SLIDING EQUIPPED BED TOTALLY INDEPENDENT. IN ADDITION TO SPACIOUS DRAWERS AND DEEP DRAWERS THIRD PULL-OUT BED CAN BE MADE CONVENIENTLY AVAILABLE THROUGH THE BELOW SPACE. ALL BEDS OF ARKIMEDE SERIES CAN BE FINISHED IN ALL LACQUERS AND MELAMINE WOODS.

LETTI SINGOLI

PER MATERASSO
DA 80 CM.

H.87 - P.92,5 - L. 215/214

LETTO SINGOLO

SINGLE BED



L. 215/214 H. 87
P. 92,5

2 LETTI

2 BEDS



2 LETTI CON 4 CASSETTI

2 BEDS WITH 4 DRAWERS



2 LETTI CON 2 CASSETTONI

2 BEDS WITH 2 DEEP DRAWERS



H.103 - P.92,5 - L. 215/214

LETTO SINGOLO ALTO

TALL SINGLE BED



L. 215/214 H. 103
P. 92,5

2 LETTI

2 BEDS



2 LETTI CON 6 CASSETTI

2 BEDS WITH 6 DRAWERS



2 LETTI CON 2 CASSETTI E 2 CASSETTONI

2 BEDS WITH 2 DRAWERS AND
2 DEEP DRAWERS



SINGLE BEDS
FOR MATTRESSES OF 80 CM.

**2 LETTI CON TERZO LETTO
ESTRAIBILE**

2 BEDS WITH THIRD PULL-OUT BED



**2 LETTI CON 2 CASSETTI
E TERZO LETTO ESTRAIBILE**

2 BEDS WITH 2 DRAWERS AND
THIRD PULL-OUT BED



ARKIMEDE

CON SCRITTOIO E CASSETTI ESTRAIBILI

IL LETTO SUPERIORE AD H.103 È PROPOSTO ANCHE CON UN DOPPIO VANO ATTREZZATO, CONFIGURABILE IN 3 SOLUZIONI: CON DOPPIO CASSETTO, CON UN CASSETTO ED UNO SCRITTOIO, CON DUE PIANI LAVORO ESTRAIBILI. PER ALLOGGIARE COSÌ IN POCO SPAZIO TUTTE LE FUNZIONI DI GIOCO/STUDIO/CONTENERE. • THE UPPER BED AT H.103 IS PROPOSED EVEN ALSO AN EQUIPPED DOUBLE COMPARTMENT, CONFIGURABLE IN 3 SOLUTIONS: WITH DOUBLE DRAWER, SINGLE DRAWER AND A DESK, WITH TWO PULL-OUT WORKTOPS. TO PUT IN SUCH A SHORT SPACE ALL THE PLAYING / STUDYING / CONTAINING FUNCTIONS.

LETTI SINGOLI PER MATERASSO DA 80 CM.

LETTO SINGOLO

SINGLE BED WITH 2 COMPARTMENTS



L. 215/214 H. 103
P. 92,5

2 LETTI

2 BEDS WITH 2 COMPARTMENTS



2 LETTI CON 4 CASSETTI

2 BEDS WITH 4 DRAWERS AND 2 COMPARTMENTS



2 LETTI CON 2 CASSETTONI

2 BEDS WITH 2 DEEP DRAWERS AND 2 COMPARTMENTS



SINGLE BEDS
FOR MATTRESSES OF 80 CM.

2 LETTI CON TERZO LETTO ESTRAIBILE

2 BEDS WITH 2 COMPARTMENTS AND
THIRD PULL-OUT BED



CONFIGURAZIONI PER LETTO H.103 CM.

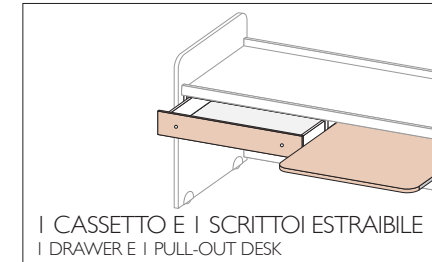
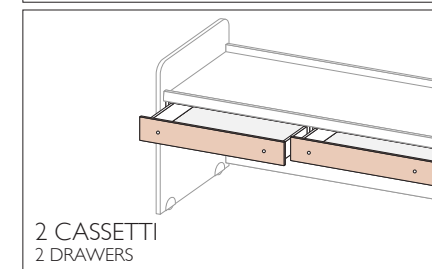
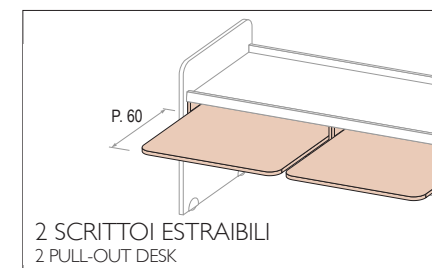

COMPARTMENT CONFIGURATIONS
FOR BEDS H. 103 CM.



TWINNY

H.70 LETTO CON 4 CASSETTI

BED WITH 4 DRAWERS



L. 202,2 H. 70
P. 87

CON 2 CONTENITORI A CASSETTONI

WITH 2 DEEP DRAWERS



CON CONTENITORI AD ANTE

WITH HINGED DOOR STORAGE BOXES



CON CONTENITORI A CASSETTI E AD ANTE

WITH 2 DRAWERS AND HINGED
DOOR STORAGE BOXES



H.86 LETTO CON 6 CASSETTI

BED WITH 6 DRAWERS

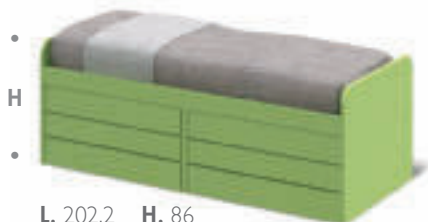

L. 202,2 H. 86
P. 87

CON CONTENITORI A CASSETTI E CASSETTONI

WITH 2 DRAWERS AND 2 DEEP DRAWERS



CON CONTENITORI AD ANTE

WITH HINGED DOOR STORAGE BOXES



CON CONTENITORI A CASSETTI E AD ANTE

WITH 3 DRAWERS AND HINGED
DOOR STORAGE BOXES



H.102 LETTO CON 8 CASSETTI

BED WITH 8 DRAWERS

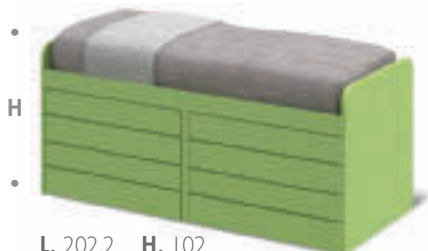

L. 202,2 H. 102
P. 87

CON CONTENITORI A CASSETTI E CASSETTONI

WITH 4 DRAWERS AND 2 DEEP DRAWERS



CON CONTENITORI AD ANTE

WITH HINGED DOOR STORAGE BOXES



CON CONTENITORI A CASSETTI E AD ANTE

WITH 4 DRAWERS AND HINGED
DOOR STORAGE BOXES



SINGLE BEDS FOR MATTRESSES OF 80 CM.

LETTI TWINNY CON CONTENITORI A CASSETTI E
PEDIERE SAGOMATE, COMPLETO DI RETE A DOGHE /
BED TWINNY WITH DRAWER CHESTS AND SHAPED
FOOTBOARDS, COMPLETE OF SLATTED BASE.

LETTITWINNY CON CONTENITORI A CASSETTI, CASSETTONI ED ANTE,
PEDIERE SAGOMATE, COMPLETO DI RETE A DOGHE /
BED TWINNY WITH DRAWER CHESTS, DEEP DRAWERS AND HINGED DOORS, SHAPED
FOOTBOARDS, COMPLETE OF SLATTED BASE.

H.86 CON SECONDO LETTO ICE*

WITH SECOND BED MOD. ICE



L. 202,2 H. 86
P. 87

*DISPONIBILE SOLO CON GAMBE E RUOTE ROLL / AVAILABLE ONLY WITH FEET AND "ROLL" WHEELS.

CON SECONDO LETTO CHAT

WITH SECOND BED MOD. CHAT



L. 210 H. 86
P. 87

LETTI SINGOLI PER MATERASSO DA 80 CM.

LETTI TWINNY CON SECONDO LETTO, PEDIERE SAGOMATE, COMPLETO DI RETE A DOGHE./ BED TWINNY WITH SECOND BED, SHAPED FOOTBOARDS, COMPLETE OF SLATTED BASE.



LA FAMIGLIA TWINNY PRESENTA UN DESIGN SOLIDO E ROBUSTO PERSONALIZZABILE SECONDO IL CAMPIONARIO LACCATURE E MELAMMINICI DIELE. I LETTI, DISPONIBILI IN 3 ALTEZZE, SONO CONFIGURATI PER LA MASSIMA RESA INTERMINI DI CAPIENZA. DAI CASSETTI SEMPLICI AI CASSETTONI, FINO AGLI SCOMPARTI AD ANTA BATTENTE. UN'AMPIA SCELTA, COMPLETATA DALLE VERSIONI CON SECONDO LETTO INFERIORE ESTRAIBILE, CON PROFILO SAGOMATO O GIROLETTO • THE TWINNY FAMILY PRESENTS A SOLID AND STRONG DESIGN TO OFFER, AND IS AVAILABLE IN ALL LACQUERS AND MELAMINE WOODS. BEDS, AVAILABLE IN 3 HEIGHTS, ARE CONFIGURED FOR MAXIMUM PERFORMANCE IN TERMS OF CAPACITY. FROM SIMPLE DRAWERS TO DEEP DRAWERS, UP TO THE COMPARTMENTS WITH HINGED DOOR. A WIDE RANGE, COMPLETED BY VERSIONS WITH SECOND LOWER EXTRACTABLE BED, SHAPED PROFILE OR BEDFRAME.

GHIRO

IL DIVANETTO “TUTTO LEGNO”

UN CLASSICO LETTO-DIVANO IDEALE PER UNA CONFIGURAZIONE SOTTOPONTE. REALIZZATO “TUTTO LEGNO” È PROPOSTO IN ESSENZA O LACCATO OPACO. I COORDINATI TESSILI ESALTANO LA LINEA DEL LETTO.

- A CLASSICAL SOFA-BED IDEAL FOR AN UNDER-BRIDGE CONFIGURATION. PRODUCED “COMPLETELY WOOD” IT'S AVAILABLE MATT LACQUERED AND IN WOOD-FINISH MELAMINE. THE TEXTILE CO-ORDINATES EMPHASIZE THE BED'S LINE.



THE SOFA-BED “COMPLETELY WOOD”





DIVANETTI

I LETTI A DIVANETTO RAPPRESENTANO UN'INTERESSANTE VARIAZIONE SUL TEMA ALL'INTERNO DELLA VASTA COLLEZIONE LETTI DIELLE, TANTO DA GUADAGNARSI UNO SPAZIO A SÈ. DOTATI DI TUTTE LE FUNZIONI A DISPOSIZIONE DELLE ALTRE VERSIONI, SONO UNA VALIDA PROPOSTA D'ARREDO PER UNO SPAZIO RAGAZZI VERSATILE, IN TRASFORMAZIONE, CHE SI PRESTA AD UN UTILIZZO INFORMALE E CREATIVO • THE SOFA BEDS REPRESENT AN INTERESTING VARIATION ON THE TOPIC INSIDE DIELLE WIDE BED COLLECTION, SO MUCH THAT EARN A PROPER SPACE. EQUIPPED WITH ALL FUNCTIONS AVAILABLE TO THE OTHER VERSIONS, THEY ARE A VALID PROPOSAL OF FURNITURE FOR A VERSATILE AND PROCESSING CHILDREN SPACE, THAT MAKES AN INFORMAL AND CREATIVE USE.



PER MATERASSO DA 80 CM.

GHIRO

DIVANETTO IN LEGNO CON SPONDE SAGOMATE, RETE A DOGHE, ANCHE CON SECONDO LETTO O CASSETTONI ESTRAIBILI/ WOODEN SOFA BED WITH SHAPED SIDES, SLATTED BASE, EXTRACTABLE BED OR DEEP DRAWERS.



L. 202,2 H. 65
P. 87

PER MATERASSO DA 80 / 90 CM.

BOSTON

DIVANETTO IN LEGNO MASSELLO SAGOMATO, ANCHE IN VERSIONE AD ELLE. ANCHE CON SECONDO LETTO O CASSETTONI ESTRAIBILI/ WOODEN SOFA BED. EVEN WITH EXTRACTABLE BED OR DEEP DRAWERS. EVEN IN L-SHAPED VERSION.



L. 209,2 H. 70
P. 91 - 99,2

MANHATTAN

DIVANETTO IMBOTTITO SFODERABILE, COMPLETO DI RETE A DOGHE. ANCHE IN VERSIONE AD ELLE./
REMOVABLE UPHOLSTERED SOFA BED, SLATTED BASE.
EVEN IN L-SHAPED VERSION.



L. 203 H¹. 75 H². 55
P. 90

DALLAS

DIVANETTO IMBOTTITO SFODERABILE, CON RETE A DOGHE E SECONDO LETTO ESTRAIBILE. ANCHE IN VERSIONE AD ELLE./
REMOVABLE UPHOLSTERED SOFA BED, SLATTED BASE AND EXTRACTABLE BED.
EVEN IN L-SHAPED VERSION.



L. 203 H. 75
P. 90

MIAMI

DIVANETTO IMBOTTITO SFODERABILE, CON RETE A DOGHE E BAULETTO CONTENITORE. ANCHE IN VERSIONE AD ELLE./
REMOVABLE UPHOLSTERED SOFA BED, SLATTED BASE AND STORAGE UNIT.
EVEN IN L-SHAPED VERSION.



L. 208 H. 75
P. 93

XBED

DIVANETTO CON SPONDE IN LEGNO O IMBOTTITE, CON 1, 2 O SENZA CASSETTI. DISPONIBILE ANCHE IN VERSIONE AD ELLE.



L. 204,2 H¹. 34 H². 70
P. 95 - 105

SOFA BED WITH UPHOLSTERED OR WOODEN BACK AND SIDES, WITH 1, 2 OR WITHOUT DRAWERS. EVEN IN L-SHAPED VERSION.



L. 212,2 H¹. 34 H². 90 DX/SX
P. 105 - 115



LETTI COMBINATI CHAT, DROP

LIBERA L'IMMAGINAZIONE!

DIELLE PROPONE UNA RICCA COLLEZIONE DI LETTI PENSATI PER UN'AREA RELAX CONFORTEVOLE E RAPPRESENTATIVA. LA POSSIBILITÀ DI COMBINARE LIBERAMENTE TESTIERE, PEDIERE E PIEDINI PERMETTE DI COMPORRE UN LETTO "PERSONALE" CHE SI ADATTA A QUALSIASI STILE DI AMBIENTE • FREE YOUR IMAGINATION! DIELE OFFERS A RICH COLLECTION OF BEDS DESIGNED FOR A REPRESENTATIVE AND COMFORTABLE RELAX AREA. THE POSSIBILITY TO FREELY COMBINE HEADBOARDS, FOOTBOARDS AND FEET ALLOWS TO DESIGN A "PERSONAL" BED ADAPT TO ANY SETTING.

COMBINED BEDS: CHAT, DROP



CHAT

LETTO CON TESTIERA E PEDIERA A TERRA

SAGOMATO / QUADRATO

CHAT BED WITH HEADBOARD/FOOTBOARD ON GROUND - SHAPED/SQUARED

FINITURE LACCATO / MELAMMINICO

ANCHE DUE LETTI FISSI GEMELLARI POSSONO TROVARE UN POSTO ADEGUATO SOTTO AL PONTE PROPOSTO DA DIELE. UN ELEGANTE CONTRAPPUNTO DI VOLUMI E COLORI CHE I RAFFINATI COORDINATI TESSILI SANNO ESALTARE • ALSO TWO FIXED BEDS TWINS CAN FIND A SUITABLE PLACE UNDER THE BRIDGE PROPOSED OF DIELE. AN ELEGANT COUNTERPOINT OF VOLUMES AND COLOURS THAT THE REFINED COORDINATED TEXTILES CAN EXALT.







Alessandra

Enrica

CHAT

LA LIBRERIA PASSANTE COSTITUISCE UN VALIDO SERVIZIO STRUTTURALE. LA FINITURA MELAMMINICO OLMO A CONTRASTO DÀ UN TOCCO DI NATURALITÀ ALL'ARREDO • THE THROUGH BOOKCASE IS A VALUABLE STRUCTURAL SERVICE. THE WOODEN CONTRASTING FINISHING GIVES A TOUCH OF NATURALNESS TO FURNISHINGS.



COLORI PURI E SOLARI



SOLAR AND PURE COLOURS



CHAT

CHAT VERSIONE CONTENITORE

CHAT BED IN THE VERSION WITH CONTAINMENT

TRASFORMARE UNA STANZA IN UN VERO E PROPRIO PROGETTO DI INTERIOR DESIGN È FACILE E DIVERTENTE: CON I COLORI E LE TEXTURE DELLE PROPOSTE DIELE SI PUÒ CREARE UN AMBIENTE IN LINEA CON LA PROPRIA PERSONALITÀ, ALL'INSEGNA DELLA CREATIVITÀ E DEL DESIGN • TRANSFORMING A ROOM INTO A REAL INTERIOR-DESIGN PROJECT IS EASY AND FUN: WITH THE COLOURS AND TEXTURES OF THE DIELE PROPOSALS AN ENVIRONMENT CAN BE CREATED TO SUIT YOUR INDIVIDUAL PERSONALITY, ALWAYS DISTINGUISHED BY CREATIVITY AND DESIGN.





LETTI CHAT | CHAT BEDS

CHAT

TESTIERA SAGOMATA



SHAPED HEADBOARDS

CHAT

CON TESTIERA E PEDIERA A TERRA

IL GIROLETTO CHAT PRESENTA NUMEROSE PROPOSTE FUNZIONALI INVERSIONE FISSA O SCORREVOLE: DAL LETTO SEMPLICE AL LETTO CON SECONDO LETTO ESTRAIBILE, CON CASSETTONI O CON AMPIO BAULETTO-CONTENITORE, DI FACILE UTILIZZO. LA SOLIDA STRUTTURA IN LEGNO, CON TESTIERA E PEDIERA A TERRA, È PERSONALIZZABILE CON 7 TIPI DI TESTIERA SAGOMATA. • CHAT BEDFRAME PRESENTS MANY FUNCTIONAL PROPOSALS FIX OR SLIDING: FROM THE SIMPLE BED TO THE BED WITH EXTRACTIBLE BED, WITH DEEP DRAWERS OR WIDE TRUNK, OF SIMPLE USE. ITS SOLID WOODEN STRUCTURE, WITH HEADBOARD AND FOOTBOARD AT FLOOR, IS CUSTOMIZABLE WITH 7 KINDS OF SHAPED HEADBOARD.

LETTI SINGOLI, PIAZZA E MEZZA

PER MATERASSO
DA 80 / 90 / 120 CM.

LETTO CHAT

LETTO FISSO CON TESTIERA E PEDIERA SAGOMATE. SCORREVOLE IN VERSIONE DA 80 E 90 CM./ FIXED BED WITH SHAPED HEADBOARD AND FOOTBOARD. SLIDING ONLY FOR MATTRESSES OF 80 / 90 CM.



L. 202,2 H¹. 49 H². 86
P. 87 - 95,2 - 127 - 172

LETTO CHAT CONTENITORE FISSO

APERTURA LATO LUNGO, TESTIERA E PEDIERA SAGOMATE, DISPONIBILE ANCHE CON RUOTE./ OPENING ON THE LONG SIDE, SHAPED HEADBOARD AND FOOTBOARD, AVAILABLE ALSO ON WHEELS.



L. 202,2 H. 49 SOLO PER MATERASSO DA 90 CM.
P. 87 ONLY FOR MATTRESS OF 90 CM.

SINGLE, THREE-QUARTER BEDS
FOR MATTRESSES OF 80 / 90 / 120 CM.

LE TESTIERE SAGOMATE

DISPONIBILI SOLO PER MATERASSI DA 80 / 90 CM.
AVAILABLE ONLY FOR MATTRESSES OF 80 / 90 CM.

TRENDY



STONDATA



ANCHE PER MATERASSI DA 120 CM.
EVEN FOR MATTRESSES OF 120 CM.



TOPINO

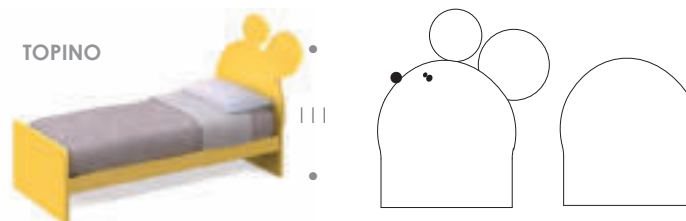

LUNA



CUORE



MARE

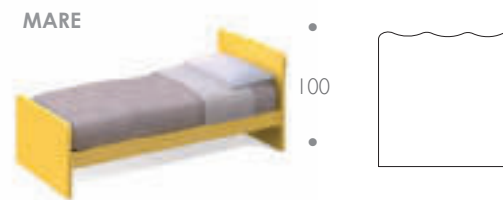

SHAPED HEADBOARDS

LE FUNZIONI

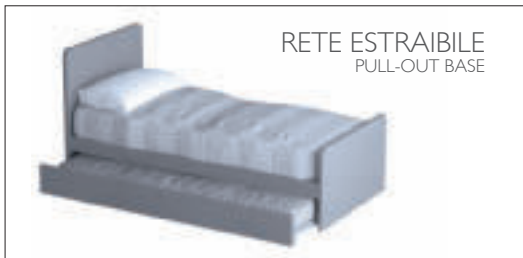

FUNCTIONS

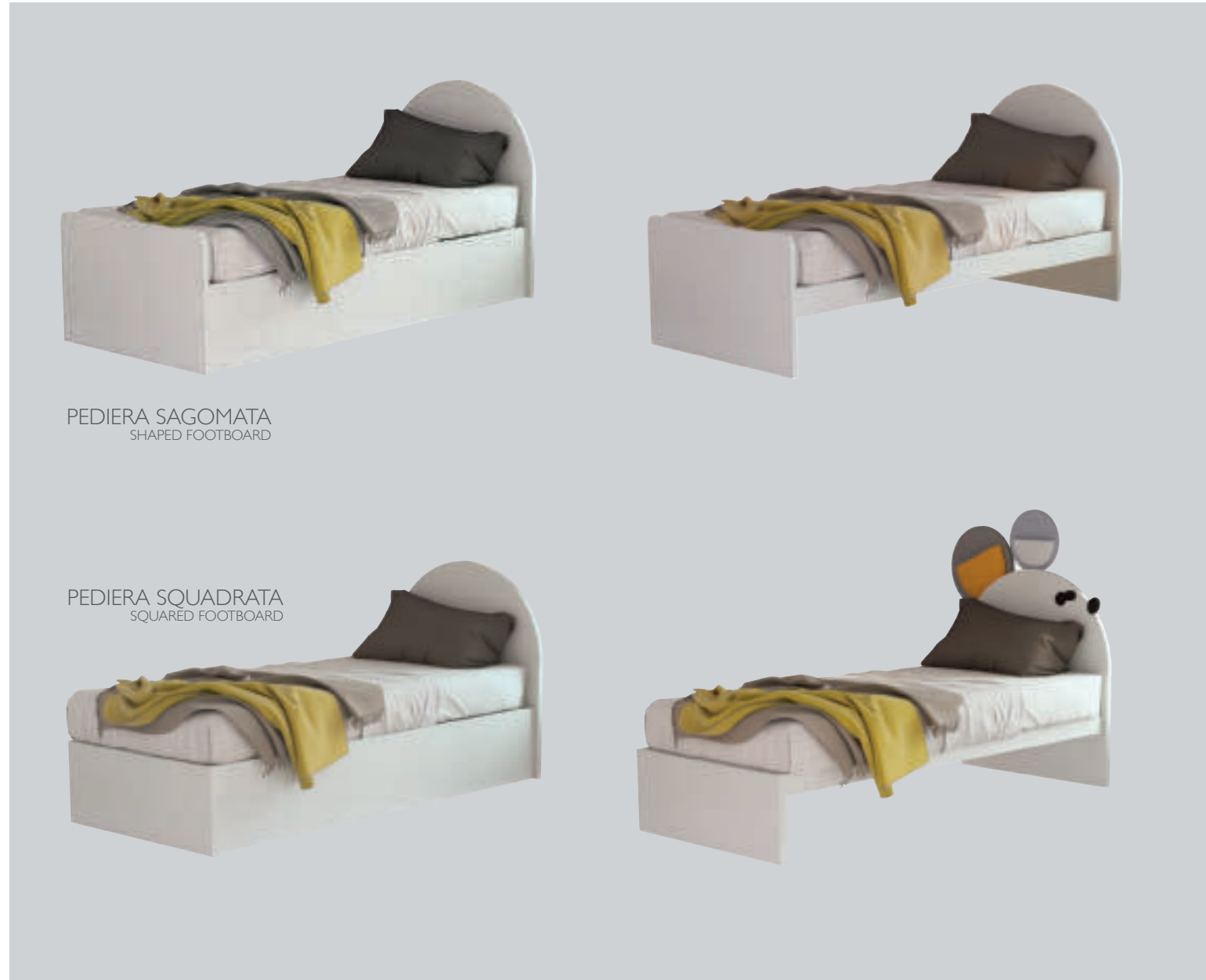

DROP

LETTO CON GAMBE O RUOTE

SAGOMATO / DRITTO

DROP IN VERSIONE "TOPINO"

ANCHE DUE LETTI FISSI GEMELLARI POSSONO TROVARE UN POSTO ADEGUATO SOTTO AL PONTE PROPOSTO DA DIELE. UN ELEGANTE CONTRAPPUNTO DI VOLUMI E COLORI CHE I RAFFINATI COORDINATI TESSILI SANNO ESALTARE • ALSO TWO FIXED BEDS TWINS CAN FIND A SUITABLE PLACE UNDER THE BRIDGE PROPOSED OF DIELE. AN ELEGANT COUNTERPOINT OF VOLUMES AND COLOURS THAT THE REFINED COORDINATED TEXTILES CAN EXALT.

DROP BED IN "LITTLE MOUSE" VERSION - WITH FEET OR WHEELS - SHAPED OR SQUARED







DROP

TESTIERA SAGOMATA



SHAPED HEADBOARDS

DROP

PIEDINI LEGNO



WOODEN FEET





DROP

LETTO CON GAMBE O RUOTE

PER MATERASSO
DA 80 / 90 / 120 CM.

LETTO DROP

CON TESTIERA E PEDIERA SAGOMATE.
WITH SHAPED HEADBOARD AND FOOTBOARD.



L. 202,2 H¹. 38,8 H². 86 - 59
P. 87 - 95,2 - 127 - 172

LETTO DROP

CON TESTIERA E PEDIERA SAGOMATE. GAMBE IN ALLUMINIO O BIANCHE. DISPONIBILI ANCHE CON PIEDE A DISCO O RUOTE/ WITH SHAPED HEADBOARD AND FOOTBOARD. ALUMINIUM OR WHITE LEGS. AVAILABLE ALSO WITH DISK FEET OR ON WHEELS.



L. 202,2 H. 38,8
P. 87 - 95,2 - 127 - 172

SINGLE, THREE-QUARTER AND DOUBLE BEDS
FOR MATTRESSES OF 80 / 90 / 120 CM.

YOUNG È PROPOSTO NELLA VARIANTE CON TESTIERA A TERRA E PIEDINI A DISCO O A CILINDRO. LA TESTIERA, SEMPRE DISPONIBILE IN 7 ORIGINALI FORME, È LIBERAMENTE INTERPRETABILE COME TUTTA LA STRUTTURA SECONDO IL CAMPIONARIO COLORI DIELE. IN FINITURE ESSENZA O LACCATE. • YOUNG IS PROPOSED IN A VERSION WITH HEADBOARD AT FLOOR AND DISK OR CYLINDER LEGS. THE HEADBOARD, ALWAYS AVAILABLE IN 7 ORIGINAL SHAPES, IS FREELY INTERPRETABLE AS THE WHOLE STRUCTURE ACCORDING TO DIELE SAMPLE COLOURS, WOODEN OR LACQUERED FINISHES.

LE TESTIERE SAGOMATE

DISPONIBILI SOLO PER MATERASSI DA 80 / 90 CM.
AVAILABLE ONLY FOR MATTRESSES OF 80 / 90 CM.

STONDATA

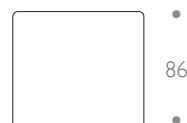
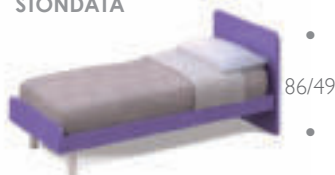

TOPINO

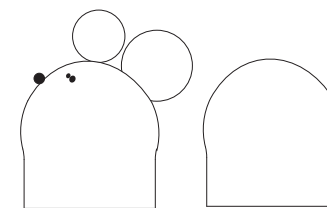

LUNA

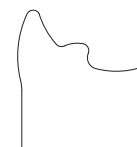

CUORE

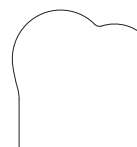

MARE

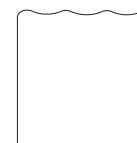

STONDATA TESTIERA SOLLEVATA



TRENDY



SHAPED HEADBOARDS

GLI ACCESSORI

PIEDE CILINDRO
CYLINDER FOOT



PIEDE DISCO
DISC FOOT

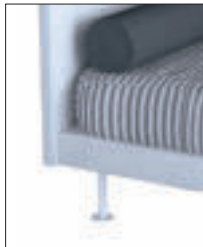

PIEDE LEGNO
WOODEN FOOT



RUOTA Ø 12 CM
WHEEL Ø 12 CM



RUOTA Ø 18 CM*
WHEEL Ø 18 CM



(*ESCLUSI LETTI DA
120 CM • EXCEPT 120
CM BEDS)

ACCESSORIES

PEDIERA SAGOMATA
SHAPED FOOTBOARD



PEDIERA SQUADRATA
SQUARED FOOTBOARD



BOSTON

UN LETTO “CON PARTI IN MASSELLO”

IL LETTO BOSTON, QUI PROPOSTO NELLA VERSIONE DIVANETTO, È IL CLASSICO LETTO “TUTTO LEGNO” CON PARTI REALIZZATE IN MASSELLO. È PROPOSTO IN LACCATO OPPURE MELAMMINICO E LEGNO • BOSTON BED, HERE PROPOSED IN THE SOFA VERSION, IT'S THE CLASSIC BED “COMPLETELY WOOD” WITH PARTS IN SOLID WOOD. IT IS AVAILABLE LACQUERED OR MELAMINE OR WOODEN FINISH.

A BED WITH SOLID WOOD COMPONENTS







Se avessi dondole
stelle, allora
qualcuno mi direbbe
più bisogno.

BOSTON



BOSTON AND THE SYSTEM ELEMENTS



BOSTON E GLI ELEMENTI DI SISTEMA

IL LETTO IN LEGNO MASSELLO BOSTON PERMETTE FACILMENTE DI INTERPRETARE LO SPAZIO RAGAZZI CON TUTTI I PLUS DISPONIBILI DEL SISTEMA. DAI COLORI AGLI STICKERS ADESIVI, DALLE ESSENZE AI COORDINATI TESSILI, TUTTO CONCORRE A PERSONALIZZARE LO SPAZIO DEL GIOCO, DELLO STUDIO, DEL RIPOSO E DEL CONTENERE. XCAB SI INTEGRA PERFETTAMENTE TRA LE FUNZIONI: TRA LETTI E LIBRERIE, TRA ELEMENTI A CONTENERE E SOPPALCHI • BOSTON BED IN SOLID WOOD ALLOWS TO EASILY SET CUSTOMISED SOLUTIONS FOR THE CHILDREN AREA TO BE CREATED WITH ALL THE SYSTEM EXTRAS. COLOUR, STICKERS, WOOD TYPES, TEXTILE COORDINATES ALL PLAY A PART IN CUSTOMISING THE PLAY, STUDY, SLEEPING AND STORAGE AREAS. THE XCAB WALK-IN CLOSET CAN BE USED: BETWEEN BEDS AND BOOKCASES, STORAGE AREAS AND ELEVATED LIVING SPACE.

BOSTON

BOSTON È UNA FAMIGLIA DI LETTI PROPOSTA IN DIVERSE CONFIGURAZIONI DALLE FORME LINEARI E FUNZIONALI. PRESENTA PARTICOLARI STRUTTURALI IN LEGNO MASSELLO SAGOMATO E SOLIDE STRUTTURE. È PROPOSTO ANCHE IN VERSIONE CON SECONDO LETTO ESTRAIBILE O CASSETTONI, IN FINITURE ESSENZA O LACCATO OPACO NEI COLORI A CAMPIONARIO • BOSTON IS A SERIES OF BEDS PRESENTED IN DIFFERENT CONFIGURATIONS WITH LINEAR AND FUNCTIONAL SHAPES. IT FEATURES STRUCTURAL DETAILS IN SHAPED SOLID WOOD AND STURDY STRUCTURES. IT IS ALSO AVAILABLE IN VERSION WITH SECOND PULL-OUT BED OR LARGE DRAWERS, IN WOOD OR MATT LACQUERED FINISHES IN THE SAMPLE RANGE OF COLOURS.



DIVANETTI PER MATERASSO DA 80 / 90 CM.

DIVANETTO BOSTON

CON 2 TESTIERE, SCHIENALE E RETE ESTRAIBILE./
WITH 2 HEADBOARDS, BACK AND EXTRACTABLE BED.



L. 209,2 H. 70 P. 91 - 99,2

DIVANETTO BOSTON

CON 2 TESTIERE, SCHIENALE E CASSETTONI ESTRAIBILI./
WITH 2 HEADBOARDS, BACK
AND EXTRACTABLE DEEP DRAWERS.



L. 209,2 H. 70 P. 91 - 99,2

SOFA BEDS
FOR MATTRESSES OF 80 / 90 CM.

**LETTI SINGOLI, PIAZZA E MEZZA
PER MATERASSO
DA 80 / 90 / 120 CM.**

LETTO BOSTON

CON TESTIERA SINGOLA /
WITH SINGLE HEADBOARD.



L. 209,2 H¹. 34 H². 70
P. 91 - 99,2 - 131

**SINGLE, THREE-QUARTER BEDS
FOR MATTRESSES OF 80 / 90 / 120 CM.**

**LETTI SINGOLI
PER MATERASSO
DA 80 / 90 CM.**

TURCA BASSA BOSTON

VERSIONE A TURCA -SOLO GIROLETTO-.
TURKISH BED VERSION -ONLY BEDFRAME-.



L. 209,2 H. 34
P. 91 - 99,2

DIVANETTO "AD ELLE" BOSTON

CON TESTIERA DX E SCHIENALE.
WITH RH HEADBOARD AND BACK.



L. 209,2 H. 70
P. 91 - 99,2

**SINGLE BEDS
FOR MATTRESSES OF 80 / 90 CM.**

DIVANETTO BOSTON

CON 2 TESTIERE E SCHIENALE.
WITH 2 HEADBOARDS AND BACK.



L. 209,2 H. 70
P. 91 - 99,2

DIVANETTO "AD ELLE" BOSTON

CON TESTIERA SX E SCHIENALE.
WITH LH HEADBOARD AND BACK.



L. 209,2 H. 70
P. 91 - 99,2



XBED

IL SISTEMA LETTO BREVETTATO

XBED LETTO/PROGETTO

XBED NON È UN SEMPLICE LETTO MA UN VERO E PROPRIO SISTEMA-
CAPACE DI OFFRIRE UN'ESTETICA DIVERSIFICATA, MAI SCONTATA E
BANALE • XBED IS NOT A SIMPLE BED BUT A REAL SYSTEM WHICH IS
ABLE TO OFFER A DIVERSIFIED AESTHETIC, NEVER OBVIOUS AND BANAL.

L'ALTERNATIVA GEOMETRICA

FORME ESSENZIALI E GEOMETRICHE SI COMPONGONO IN UN
INSIEME BILANCIATO DI ELEMENTI CHE DANNO VITA A LETTI SOR-
PRENDENTI • ESSENTIAL AND GEOMETRIC SHAPES COMPOSE A
BALANCED SET OF ELEMENTS GIVING LIFE TO AMAZING BEDS.

XBED THE REGISTERED BED SYSTEM



XBED

SISTEMA LETTO

BED SYSTEM

LETTI SINGOLI E PIAZZA E MEZZA
PER MATERASSO DA 80/90/120 CM
SINGLE, DOUBLE AND THREE-QUARTER FOR
MATTRESSES OF 80/90/120 CM.

SCHIENE TESSILI

FABRIC BACK PANELS

TESTIERE TESSILI

UPHOLSTERED
HEADBOARDS

TESTIERE LEGNO

WOOD HEADBOARDS

PIEDINI

FEET

SCHIENA SAGOMATA

SHAPED BACK PANEL

SCHIENE LEGNO

WOOD BACK PANELS

PIANALE

TOP

CONTENITORE

STORAGE UNIT

SACCA

CONTAINER

XBED È UN PROGETTO-LETTO TOTALMENTE INNOVATIVO: UN'IDEA DIVERTENTE BASATA SULL'AGGREGAZIONE LIBERA E CREATIVA DI FORME GEOMETRICHE PURE, PENSATE PER ESSERE I COMPONENTI STRUTTURALI DEL LETTO. IL CASSETTO, IL PIEDE O LA TESTIERA SONO ELEMENTI GRAFICI PRIMA ANCORA CHE FUNZIONALI. NON CI SONO LIMITI ALLA PERSONALITÀ DI CIASCUNO: TESSUTI, LACCATI, LEGNI E TEXTURE SI PRESTANO ORA AD UN GIOCO INFANTILE DI FORME E COLORI, ORA AD UN RIGOROSO ABBINAMENTO DI TONI IN BIANCO E NERO. NON CI SONO LIMITI ALLE STRUTTURE: LETTINO, DIVANO, LETTI PIAZZA E MEZZA, LETTI-CONTENITORE, DIVANETTI AD ELLE E PERSINO IL LETTO VIS-A-VIS. NON CI SONO LIMITI ALLE FORME: TRADIZIONALI O GEOMETRICHE, DAL DESIGN RIGOROSO O DA MORBIDI COMPONENTI TESSILI. NON CI SONO LIMITI • XBED IS A COMPLETELY INNOVATIVE BED PROJECT: A FUNNY IDEA BASED ON THE FREE AND CREATIVE COMBINATION OF PURE GEOMETRIC SHAPES, STUDIED TO BE THE STRUCTURAL COMPONENTS OF THE BED. THE DRAWER, THE FEET OR THE HEADBOARD ARE GRAPHIC ELEMENTS EVEN BEFORE FUNCTIONAL. THERE ARE NO LIMITS TO PEOPLE'S PERSONALITY: FABRICS, LACQUERED FINISHES, WOOD FINISHES AND TEXTURE ARE SOMETIMES PRESENTED TO A CHILDISH GAME OF SHAPES AND COLOURS, SOMETIMES TO A RIGOROUS COMBINATION OF WHITE & BLACK TONES. NO LIMITS FOR STRUCTURES: CRIB, SOFA, FRENCH SIZE BEDS, STORAGE BOX BEDS, L-SHAPED SMALL SOFAS AND ALSO THE VIS-A-VIS BED. NO LIMITS TO SHAPES: TRADITIONAL OR GEOMETRIC, BY A RIGOROUS DESIGN OR SOFT TEXTILE COMPONENTS.



TIPOLOGIE / TYPOLOGY

LETTO

BED



DECORATIVO

DECORATIVE

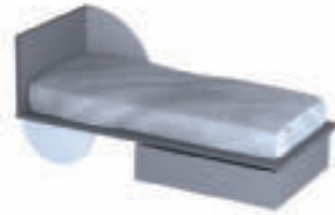

DIVANETTO/CONTENITORE

SOFA/STORAGE UNIT



PLUS

CASSETTO BREVETTATO

L'INNOVATIVO SISTEMA BREVETTATO DI CASSETTONI GUIDATI, TRASFORMA LO SPAZIO SOTTO IL PIANALE IN UNA ZONA AD ALTA FUNZIONALITÀ. FACILMENTE ACCESSIBILI E SPAZIOSI, IN GRADO DI ACCOGLIERE CORREDI TESSILI, CUSCINI E VESTIARIO PER LA NOTTE. DISPONIBILI IN TUTTE LE FINITURE: COLORE, TEXTURE ED EFFETTO LEGNO • AN INNOVATIVE PATENTED PRODUCT, WHICH THANKS TO THE GUIDED LARGE DRAWERS, TRANSFORMS THE SPACE UNDER THE TOP INTO A HIGHLY FUNCTIONAL AREA. THEY ARE EASY TO ACCESS AND SPACIOUS AND CAN CONTAIN BED LINEN, PILLOWS AND SLEEPWEAR. AVAILABLE IN ALL COLOR FINISHES, TEXTURES AND WOOD EFFECT.

RETE

XBED PROPONE UN PIANALE IN LEGNO MULTISTRATO PER IL MASSIMO COMFORT DI RIPOSO CON FERITOIE STUDIATE PER L'AREAZIONE DEI TESSUTI E DEI MATERASSI. IL PIANALE RIGIDO PREVIENE LE DANNOSE DEFORMAZIONI DEL PIANO LETTO. È UN PRODOTTO ECO-COMPATIBILE TOTALMENTE RICICLABILE • XBED PRESENTS A MULTIPLY WOOD STOP FOR UTMOST SLEEPING COMFORT WITH SLATS DESIGNED FOR THE REACTION OF FABRICS AND MATTRESSES. THE RIGID TOP PREVENTS HARMFUL DEFORMATIONS OF THE BED TOP. AN ECO-COMPATIBLE TOTALLY RECYCLABLE PRODUCT.

SACCA ANTIPOLVERE

IL CASSETTO CONTENITORE ESTRAIBILE PRESENTA UN'INNOVATIVA APERTURA GUIDATA ED HA UNA CAPACITÀ CONTENITIVA PARI A 150 LITRI. LA PRATICA SACCA CONTENITORE ANTIPOLVERE CON APERTURA A ZIP È ASPORTABILE E LAVABILE PER LA MASSIMA CURA E PULIZIA • THE REMOVABLE STORAGE UNIT FEATURING AN INNOVATIVE GUIDED OPENING AND A STORAGE CAPACITY OF 150 LITRES. THE PRACTICAL ANTI-DUST CONTAINER BAG WITH ZIP FASTENER CAN BE REMOVED AND WASHED FOR UTMOST CARE AND CLEANLINESS.





XBED SISTEMA LETTO BED SYSTEM

DIELLE, AZIENDA LEADER NEL SETTORE SPAZIO GIOVANE, SPINGE LA PROPRIA RICERCA VERSO L'INNOVAZIONE FUNZIONALE DEI PRODOTTI. XBED SISTEMA LETTO BREVETTATO È UN PRODOTTO INNOVATIVO CHE GRAZIE AI CASSETTONI GUIDATI, TRASFORMA LO SPAZIO SOTTO IL PIANALE IN UNA ZONA AD ALTA FUNZIONALITÀ • DIELLE, LEADING MANUFACTURER OF YOUNG AREAS, DRIVES ITS RESEARCH TO PRODUCT FUNCTIONAL INNOVATION. THE PATENTED XBED SYSTEM IS AN INNOVATIVE PRODUCT, WHICH THANKS TO THE GUIDED LARGE DRAWERS, TRANSFORMS THE SPACE UNDER THE TOP INTO A HIGHLY FUNCTIONAL AREA.

SACCA ANTIPOLVERE



SISTE
MA
BRE
VET
TATO



BREVETTO: SISTEMA SCORREVOLE SOTTOLETTO



I COMODI CASSETTONI SOTTO LETTO SONO FACILMENTE ACCESSIBILI E SPAZIOSI, IN GRADO DI ACCOGLIERE CORREDI TESSILI, CUSCINI E VESTIARIO PER LA NOTTE. LA SACCA ANTIPOLVERE CONSENTE UN ALLOGGIAMENTO AL SICURO DALLA POLVERE PER UNA MAGGIOR PULIZIA • THE CONVENIENT LARGE DRAWERS UNDERNEATH THE BED ARE EASY TO ACCESS AND SPACIOUS AND CAN CONTAIN BED LINEN, PILLOWS AND SLEEPWEAR. THE ANTI-DUST BAG ALLOWS A SAFE FROM DUST HOUSING FOR A GREATER CLEANLINESS.

XBED SISTEMA LETTO BED SYSTEM

DESIGN, ERGONOMIA E FUNZIONE SONO ALLA BASE DEL PROGETTO XBED. FORME GEOMETRICHE ESSENZIALI DANNO ORIGINE A LETTI CREATIVI CHE TROVANO NELLE CAMERE DEI RAGAZZI UN'IDEALE COLLOCAZIONE. IL COLORE PROPOSTO NEI CROMATISMI DI SISTEMA UN PLANNING RISPONDENTE AD OGNI ESIGENZA DI PERSONALIZZAZIONE E I MATERIALI GIOCA UN RUOLO DETERMINANTE AI FINI DEL PROGETTO-LETTO • DESIGN, ERGONOMICS AND FUNCTION ARE AT THE BOTTOM OF THE XBED PROJECT. ESSENTIAL GEOMETRIC SHAPES ORIGINATE CREATIVE BEDS WHICH FIND AN IDEAL COLLOCATION IN CHILDREN'S ROOMS. SYSTEM COLOURS ARE ABLE TO CATER TO ANY PERSONALISATION REQUIREMENT AND THE MATERIALS PLAY A DECISIVE ROLE FOR PROJECT-BED PURPOSES.



LETTO XBED CON TESTIERE PANNELLO LACCATO / XBED BED WITH LACQUERED HEADBOARDS



XBED

SISTEMA LETTO
BED SYSTEM



XBED PROPONE UN PIANALE IN LEGNO MULTISTRATO PER IL MASSIMO COMFORT DI RIPOSO CON FERITOIE STUDIATE PER L'AREAZIONE DEI TESSUTI E DEI MATERASSI. IL PIANALE RIGIDO PREVIENE LE DANNOSE DEFORMAZIONI DEL PIANO LETTO, È UN PRODOTTO ECO-COMPATIBILE TOTALMENTE RICICLABILE • XBED PRESENTS A MULTIPLY WOOD STOP FOR UTMOST SLEEPING COMFORT WITH SLATS DESIGNED FOR THE REACTION OF FABRICS AND MATTRESSES. THE RIGID TOP PREVENTS HARMFUL DEFORMATIONS OF THE BED TOP, AN ECO-COMPATIBLE TOTALLY RECYCLABLE PRODUCT.

LETTO XBED CON TESTIERE LEGNO / XBED BED WITH WOODEN HEADBOARDS







XBED

SISTEMA LETTO
BED SYSTEM



XBED QUI PROPOSTO CON PARTI IN MELAMMINICO OLMO NATURALE, È STATO STUDIATO PER INTEGRARSI NEI SISTEMI DIELLE. PUÒ ACCOSTARE IL LETTO CONTAINER, LE CABINE ARMADIO, GLI SPAZI SOTTOPONTE • XBED HERE PROPOSED WITH NATURAL ELM MELAMINE PARTS, IT HAS BEEN STUDIED TO INTEGRATE THE DIELLE SYSTEM. CAN BE CONNECTED WITH THE CONTAINER BED, THE WARDROBE CABS, THE UNDER-BRIDGE SPACES.

LETTO XBED CON TESTIERE LEGNO / XBED BED WITH WOODEN HEADBOARDS



XBED IL LETTO PIÙ FASHION

XBED
SISTEMA LETTO
BED SYSTEM



XBED PROGETTO LETTO È PERFETTAMENTE INTEGRATO AGLI ELEMENTI DI SISTEMA, CREANDO UNA FLUENTE CONTINUITÀ DI DISEGNO CHE STABILISCE IL GRADO DI EVOLUZIONE TECNICA RAGGIUNTA DAL PRODOTTO • THE XBED PROJECT IS PERFECTLY INTEGRATED WITH THE SYSTEM ELEMENTS, CREATING A FLUENT DESIGN CONTINUITY WHICH ESTABLISHES THE DEGREE OF TECHNICAL EVOLUTION ACHIEVED BY THE PRODUCT.

XBED

SISTEMA LETTO
BED SYSTEM



LO SPAZIO DEL RIPOSO DIVENTA UN'AREA DI SOCIALIZZAZIONE DOVE RICEVERE GLI AMICI, CONVERSARE... O SEMPLICEMENTE PER UNA SANA LETTURA. LA POSTAZIONE STUDIO GIOCO È UNA FINESTRA SUL MONDO, PER ESPORARE E CONDIVIDERE ESPERIENZE ON LINE. COSÌ DIELLE OGGI PROPONE SOLUZIONI D'ARREDO SPECIALISTICHE, NEL SEGNO DEL DESIGN E DELL'INNOVAZIONE • THE REST AREA BECOMES A PLACE TO SOCIALISE, RECEIVE FRIENDS, TALK... OR READ A GOOD BOOK. THE STUDY/PLAY AREA IS A WINDOW ON THE WORLD, TO EXPLORE AND SHARE EXPERIENCES ONLINE. AND SO TODAY DIELLE PRESENTS SPECIALISED FURNISHING SOLUTIONS, DISTINGUISHED BY DESIGN AND INNOVATION.







XBED

SISTEMA LETTO
BED SYSTEM



LETTO XBED CON TESTIERE LEGNO E IMBOTTITE / XBED BED WITH WOODEN AND UPHOLSTERED HEADBOARDS



LETTO XBED CON TESTIERE IMBOTTITE / XBED BED WITH UPHOLSTERED HEADBOARDS



LETTI TESSILI MORBIDE IMBOTTITURE PER IL TUO COMFORT

LE TESTIERE IMBOTTITE

LA COLLEZIONE DI LETTI TESSILI DIELE PROPONE UNA RICCA DECLINAZIONE DI LETTI DAL DESIGN RAFFINATO CHE SANNO VALORIZZARE OGNI AMBIENTE • THE DIELE TEXTILE BEDS COLLECTION OFFERS A WIDE SET OF BEDS WITH A REFINED DESIGN, THEY KNOW HOW TO ENHANCE EVERY ROOM.

I TESSUTI COORDINATI

LE COLLEZIONI TESSILI PROPONGONO TESSUTI NATURALI E MATERICI, IDEALI PER ESSERE ACCOSTATI ALLE LACCATURE E AI MELAMMINICI OLMO DI SISTEMA • THE TEXTILE COLLECTIONS SUGGEST NATURAL AND TACTIL FABRICS, IDEAL TO BE APPROACHED TO THE LACQUERINGS AND TO THE SYSTEM ELM MELAMINES.

TEXTILE BEDS: SOFT PADDINGS FOR YOUR COMFORT





GIROLETTO MONTREAL - TESTIERA MODELLO AMBRA / MONTREAL BEDFRAME - HEADBOARD MODEL AMBRA

MONTREAL





MONTREAL È IL CLASSICO GIROLETTO "SOSPESO" IL SUO SPESSORE RIDOTTO TRASMETTE UN'IDEA DI LEGGEREZZA E STABILITÀ. PUÒ ESSERE DOTATO DI GAMBE IN METALLO O LEGNO OPPURE MONTATO SU RUOTE PER FACILI SPOSTAMENTI • MONTREAL IS THE CLASSIC "SUSPENDED" BED FRAME, ITS SMALL THICKNESS CONVEYS AN IDEA OF LIGHTNESS AND STABILITY. IT CAN BE EQUIPPED WITH WOODEN OR METAL LEGS OR IT CAN BE MOUNTED ON WHEELS FOR EASY MOVEMENTS.

MONTREAL



PIEDINI FISSI / FIXED FEET

MONTREAL GIROLETTO

LETTI SINGOLI E PIAZZA E MEZZA
PER MATERASSO DA 80/90/120 CM
SINGLE AND THREE-QUARTER FOR MATTRESSES
OF 80/90/120 CM.

CON TESTIERA DIANA

TESTIERA IMBOTTITA ASPORTABILE /
REMOVABLE UPHOLSTERED HEADBOARD.



L. 215 H. 98
P. 105 - 115 - 145

CON TESTIERE AMBRA / LISA

TESTIERA IMBOTTITA ASPORTABILE /
REMOVABLE UPHOLSTERED HEADBOARD.



L. 209 H. 98
P. 103 - 113 - 143 AMBRA
P. 101 - 111 - 141 LISA

AMBRA

CON PANNELLO
RIVESTITO IN TESSUTO /
WITH FABRIC COVERED
PANEL.



LISA

CON PANNELLO
IN MELAMMINICO /
WITH MELAMINE PANEL.



CON TESTIERA ALICE

TESTIERA IMBOTTITA TRAPUNTATA /
QUITTED UPHOLSTERED HEADBOARD.



L. 215 H. 98
P. 105 - 115 - 145

CON TESTIERE CAMILLA / NOEMI

TESTIERA IMBOTTITA TRAPUNTATA ASPORTABILE /
REMOVABLE QUITTED UPHOLSTERED HEADBOARD.



L. 212 H. 98
P. 103 - 113 - 143 CAMILLA
P. 101 - 111 - 141 NOEMI

CAMILLA

CON PANNELLO
RIVESTITO IN TESSUTO /
WITH FABRIC
COVERED PANEL.



NOEMI

CON PANNELLO
IN MELAMMINICO /
WITH MELAMINE PANEL.



IL SOMMIER MONTREAL CON
GIROLETTO IMBOTTITO BASSO
BED WITH UPHOLSTERED BED FRAME.

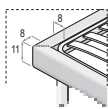

L. 212 H. 34
P. 97 - 107 - 137

IL GIROLETTO MONTREAL È DISPONIBILE CON PIEDINI O MONTATO SU RUOTE PER FACILI
SPOSTAMENTI. IL PIANALE LETTO LEGGERO E "AEREO" ESALTA IL DISEGNO DELLE TESTIERE TESSILI
DAI CROMATISMI PURI. • MONTREAL BEDFRAME IS AVAILABLE WITH FEET OR ON WHEELS FOR
EASY MOVEMENTS. THE LIGHT FLOOR OF THE BED ENHANCES THE DESIGN OF TEXTILE
HEADBOARDS FROM PURE COLOURS.

GLI ACCESSORI / ACCESSORIES

PIEDE CILINDRO
CYLINDER
FOOT

PIEDE DISCO
DISC FOOT

RUOTA
Ø 12 CM
WHEEL Ø 12 CM

RUOTA
Ø 18 CM
WHEEL Ø 18 CM

PIEDE LEGNO
WOODEN
FOOT

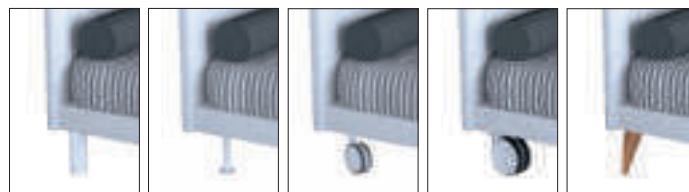

(ESCLUSI LETTI DA 120 CM
¥ EXCEPT 120 CM BEDS)







GIROLETTO HAVANA - TESTIERA MODELLO CAMILLA / HAVANA BEDFRAME - HEADBOARD MODEL CAMILLA

HAVANA



HAVANA

LETTI SINGOLI E PIAZZA E MEZZA
PER MATERASSO DA 80/90/120 CM
SINGLE, DOUBLE AND THREE-QUARTER FOR
MATTRESSES OF 80/90/120 CM.

CON TESTIERA DIANA

TESTIERA IMBOTTITA /
UPHOLSTERED HEADBOARD.



L. 220 H. 98
P. 115 - 125 - 155

CON TESTIERA AMBRA

TESTIERA IMBOTTITA ASPORTABILE /
REMOVABLE UPHOLSTERED HEADBOARD.



L. 215 H. 98
P. 115 - 125 - 155

CON TESTIERA ALICE

TESTIERA IMBOTTITA TRAPUNTATA /
QUITTED UPHOLSTERED HEADBOARD.



L. 220 H. 98
P. 115 - 125 - 155

CON TESTIERA CAMILLA

TESTIERA IMBOTTITA TRAPUNTATA ASPORTABILE /
REMOVABLE QUITTED UPHOLSTERED HEADBOARD.



L. 230 H. 98
P. 115 - 125 - 155

CON TESTIERA VITTORIA

TESTIERA IMBOTTITA "A CUSCINO" /
"CUSHION-SHAPED" UPHOLSTERED
HEADBOARD.



L. 230 H. 98
P. 117 - 127 - 157

AMBRA

CON PANNELLO
RIVESTITO IN TESSUTO /
WITH FABRIC COVERED
PANEL.



CAMILLA

CON PANNELLO
RIVESTITO IN TESSUTO /
WITH FABRIC
COVERED PANEL.



IL SOMMIER HAVANA
CON RETE FISSA O CON APERTURA
RETE CONTENITORE
BED WITH FIXED BASE OR WITH
STORAGE BOX OPENING



L. 230 H. 32
P. 113 - 123 - 153

HAVANA PRESENTA UN GIROLETTO IMBOTTITO COMPLETAMENTE SFODERABILE. È ATTREZZABILE CON CONTENITORE TOTALMENTE APRIBILE PER UN COMODO ACCESSO AL VANO INTERNO. SI CARATTERIZZA PER UNA FORMA SIMPATICAMENTE TONDEGGIANTE, ALLA QUALE ACCOSTARE LE MORBIDE TESTIERE DI SERIE IMBOTTITE • HAVANA PRESENTS A COMPLETELY REMOVABLE UPHOLSTERED BEDFRAME. IT IS EQUIPPABLE WITH STORAGE BOX COMPLETELY OPENABLE FOR AN EASY ACCESS TO THE INTERNAL COMPARTMENT. IT IS CHARACTERIZED BY A PLEASANTLY ROUNDED SHAPE, TO WHICH JUXTAPOSE THE STANDARD SOFT PADDED HEADBOARDS.

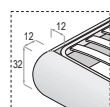



BALTIMORA / CASABLANCA





GIROLETTO BALTIMORA - TESTIERA MODELLO CAMILLA / BALTIMORA BEDFRAME - HEADBOARD MODEL CAMILLA



BALTIMORA SOMMIER / BALTIMORA SOMMIER

BALTIMORA / CASABLANCA



CASABLANCA



GIROLETTO CASABLANCA - TESTIERA MODELLO DIANA / CASABLANCA BEDFRAME - HEADBOARD MODEL DIANA





CASABLANCA È UN GIROLETTO TESSILE DOTATO DI UN PRATICO CONTENITORE PER L'ARCHIVIO DEI COORDINATI TESSILI E OGGETTI D'USO DOMESTICO. ASSOCIABILE ALLE TESTIERE TESSILI OPPURE RIVESTITE IN ECO-PELLE • CASABLANCA IS A TEXTILE BED FRAME EQUIPPED WITH A PRACTICAL STORAGE BOX USED TO CONTAIN HOUSEHOLD OBJECTS. CONNECTABLE WITH TEXTILE OR UPHOLSTERED WITH ECO-LEATHER HEADBOARDS.

CASABLANCA



GIROLETTO CASABLANCA - TESTIERA MODELLO ALICE / CASABLANCA BEDFRAME - HEADBOARD MODEL ALICE

BALTIMORA

GIROLETTO IMBOTTITO ALTO
BED WITH TALL UPHOLSTERED BED FRAME

CASABLANCA

GIROLETTO IMBOTTITO CON CONTENITORE
BED WITH STORAGE BED

LETTI SINGOLI E PIAZZA E MEZZA
PER MATERASSO DA 80/90/120 CM
SINGLE, DOUBLE AND THREE-QUARTER FOR
MATTRESSES OF 80/90/120 CM.

CON TESTIERA DIANA

TESTIERA IMBOTTITA /
UPHOLSTERED HEADBOARD.



L. 215 H. 98
P. 105 - 115 - 145

CON TESTIERA AMBRA

TESTIERA IMBOTTITA ASPORTABILE /
REMOVABLE UPHOLSTERED HEADBOARD.



L. 209 H. 98
P. 103 - 113 - 143

CON TESTIERA ALICE

TESTIERA IMBOTTITA TRAPUNTATA /
QUITTED UPHOLSTERED HEADBOARD.



L. 215 H. 98
P. 105 - 115 - 145

CON TESTIERE CAMILLA / NOEMI

TESTIERA IMBOTTITA TRAPUNTATA ASPORTABILE /
REMOVABLE QUITTED UPHOLSTERED HEADBOARD.



L. 212 H. 98
P. 103 - 113 - 143 CAMILLA
P. 101 - 111 - 141 NOEMI

CON PANNELLO
RIVESTITO IN TESSUTO /
WITH FABRIC COVERED
PANEL.



CAMILLA

CON PANNELLO
RIVESTITO IN TESSUTO
/ WITH FABRIC
COVERED PANEL.



NOEMI

CON PANNELLO
IN MELAMMINICO/
WITH MELAMINE
PANEL.



IL SOMMIER BALTIMORA CON GIROLETTO IMBOTTITO ALTO BED WITH TALL UPHOLSTERED BED FRAME

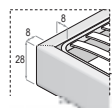

L. 212 H. 34
P. 97 - 107 - 137

IL SOMMIER CASABLANCA CON CONTENITORE BED WITH STORAGE BED

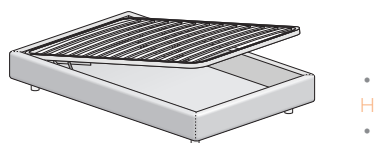

L. 212 H. 34
P. 97 - 107 - 137

CARATTERIZZATO DA UN'IMPORTANTE BASE TESSILE IMBOTTITA, IL GIROLETTO BALTIMORA È DISPONIBILE IN TUTTE LE DIMENSIONI... DAL LETTO SINGOLO, AL PIAZZA E MEZZO AL MATRIMONIALE. LE TESTIERE PERSONALIZZANO OGNI SINGOLA PROPOSTA PER UN PLANNIG CREATIVO. IN VERSIONE CASABLANCA PROPONE UN CAPIENTE CONTENITORE APRIBILE CON MOVIMENTO AGEVOLATO • CHARACTERIZED BY AN IMPORTANT UPHOLSTERED TEXTILE BASE, BEDFRAME BALTIMORA IS AVAILABLE IN ALL DIMENSIONS... SINGLE BED, FRENCH SIZE OR TWIN BED. THE HEADBOARDS CUSTOMIZE EVERY SINGLE PROPOSAL FOR A CREATIVE PLANNING. IN CASABLANCA VERSION IT OFFERS A LARGE OPENABLE BOX WITH EASY MOVEMENT.





DIVANETTI IMBOTTITI MIAMI, DALLAS, MANHATTAN

IL LETTO/DIVANETTO IMBOTTITO

NELL'AREA GIOVANI IL LETTO RAPPRESENTA NON SOLO LO SPAZIO DEL RIPOSO, MA ANCHE UN LUOGO DI RELAX E SOCIALIZZAZIONE. LA COLLEZIONE DI LETTITESSILI PROPONE LETTI A SOMMIER, A DIVANETTO - CON UNO OPPURE DUE BRACCIOLI - IN VERSIONE CONTENITORE AD APERTURA SIA LONGITUDINALE CHE FRONTALE O CON SECONDO LETTO ESTRAIBILE. INOLTRE SONO PROPOSTE LE VERSIONI CON PIEDINI DI DIVERSE TIPOLOGIE. • IN THE YOUNG PEOPLE AREA THE BED IS NOT ONLY A SPACE DEDICATED TO THE REST BUT ALSO A PLACE FOR RELAX AND SOCIALIZATION. THE COLLECTION OF TEXTILE BEDS PROPOSES SOMMIER BEDS, SOFA BEDS WITH ONE OR TWO ARMRESTS, WITH CONTAINMENT BELOW TO BE OPENED ON A LONG SIDE OR ON THE FOOT SIDE OR WITH THE LOWER EXTRACTIBLE BED. BESIDES THERE ARE SEVERAL VERSIONS WITH DIFFERENT KIND OF FEETS.

UPHOLSTERED SOFA/BEDS: MIAMI, DALLAS, MANHATTAN





MIAMI
DIVANETTO/
SOFA BED



MIAMI SI DIFFERENZIA DA DALLAS PERCHÈ PRESENTA IL CONTENITORE CON SISTEMA DI APERTURA LONGITUDINALE. DALLAS INVECE PRESENTA IL SOMMIER DOTATO DI SECONDO LETTO ESTRAIBILE • MIAMI IS DIFFERENT FROM DALLAS BECAUSE ITS CONTAINER OPENS LONGITUDINALLY. DALLAS IS EQUIPPED WITH A SECOND EXTRACTIBLE BED.

LETTO MIAMI CON DUE TESTIERE E SCHIENALE / MIAMI BED WITH TWO HEADBOARDS WITH SLATTED BASE

MIAMI / DALLAS

DIVANETTI / SOFA BEDS

IL SOMMIER MIAMI
CONTENITORE TESSILE
UPHOLSTERED STORAGE UNIT



LETTO SOMMIER MIAMI

LETTO IMBOTTITO SFODERABILE, RETE A DOGHE CON APERTURA A CONTENITORE.
REMOVABLE UPHOLSTERED BED, SLATTED BASE WITH STORAGE BOX OPENING.



L. 208 H. 35
P. 93

DIVANETTO "AD ELLE" MIAMI

LETTO IMBOTTITO SFODERABILE CON TESTIERA DX/SX, RETE A DOGHE CON APERTURA A CONTENITORE / REMOVABLE UPHOLSTERED BED, WITH RH/LH HEADBOARD, SLATTED BASE WITH STORAGE BOX OPENING.



L. 208 H. 75
P. 93

DIVANETTO MIAMI

LETTO IMBOTTITO SFODERABILE CON 2 TESTIERE, RETE A DOGHE CON APERTURA A CONTENITORE.
REMOVABLE UPHOLSTERED BED WITH 2 HEADBOARDS, SLATTED BASE WITH STORAGE BOX OPENING.



L. 208 H. 75
P. 93

IL SOMMIER DALLAS
SECONDO LETTO ESTRAIBILE
SECOND PULL-OUT BED



LETTO SOMMIER DALLAS

LETTO IMBOTTITO SFODERABILE, RETE A DOGHE E SECONDO LETTO ESTRAIBILE.
REMOVABLE UPHOLSTERED BED, SLATTED BASE AND EXTRACTABLE BED.



L. 203 H. 35
P. 90

DIVANETTO "AD ELLE" DALLAS

LETTO IMBOTTITO SFODERABILE CON TESTIERA DX/SX, RETE A DOGHE E SECONDO LETTO ESTRAIBILE / REMOVABLE UPHOLSTERED BED, WITH RH/LH HEADBOARD, SLATTED BASE AND EXTRACTABLE BED.



L. 203 H. 75
P. 90

DIVANETTO DALLAS

LETTO IMBOTTITO SFODERABILE CON 2 TESTIERE, RETE A DOGHE E SECONDO LETTO ESTRAIBILE.
REMOVABLE UPHOLSTERED BED WITH 2 HEADBOARDS, SLATTED BASE AND EXTRACTABLE BED.



L. 203 H. 75
P. 90

MIAMI E DALLAS SONO LETTI A SOMMIER DALLE FORME ERGONOMICHE ED ESSENZIALI. MIAMI PRESENTA UN PRATICO CONTENITORE IDEALE PER RIPORRE I COORDINATI TESSILI, DALLAS PROPONE UN SECONDO LETTO ESTRAIBILE A SCOMPARSA. I LETTI SFODERABILI PROPOSTI IN DIVERSE CONFIGURAZIONI SONO ASSOCIABILI ALLE PARETI TESSILI AL METRO LINEARE. LE PARETI TESSILI SONO ISOLANTI PER UN ELEVATO COMFORT. • MIAMI AND DALLAS ARE SOFA BEDS WITH ERGONOMIC AND ESSENTIAL SHAPES. MIAMI FEATURES A PRACTICAL STORAGE UNIT IDEAL FOR STORING COORDINATED BED LINEN, DALLAS FEATURES A SECOND INTEGRATED PULL-OUT BED. THE BEDS WITH REMOVABLE COVERS PRESENTED IN DIFFERENT CONFIGURATIONS ARE ASSOCIABLE WITH THE TEXTILE WALLS PER LINEAR METRE. THE TEXTILE WALLS ARE INSULATING FOR EXTRA COMFORT.







LETTO MANHATTAN CON TESTIERA E SCHIENALE / MANHATTAN BED WITH HEADBOARDS WITH SLATTED BASE

MANHATTAN

LETTI/DIVANETTI | SOFA/BEDS

LETTO DIVANO IMBOTTITO RIVESTITO IN TESSUTO SFODERABILE CON GAMBE CONICHE LEGNO • UPHOLSTERED SOFA BED COVERED WITH REMOVABLE FABRIC WITH WOODEN CONICAL LEGS.



PIEDINI LEGNO / WOODEN FEET



LETTO MANHATTAN CON DUE TESTIERE E SCHIENALE / MANHATTAN BED WITH TWO HEADBOARDS WITH SLATTED BASE

MANHATTAN

LETTI/DIVANETTI | SOFA/BEDS

UN TOCCO DI "MEMORIA" ESALTATO AD ARTE ALLA CLASSICITÀ DI ALCUNI DETTAGLI DI STILE COME IL PIEDINO TORNITO DEL LETTO TESSILE, QUESTO GIOCO DI FORME E FINITURE ESALTA LA SCELTA INDIVIDUALE SIA NEI MASSIMI SISTEMI CHE NEL DETTAGLIO EMOZIONALE, DANDO LA MISURA DEL GRADO DI SPECIALIZZAZIONE DEL PRODOTTO DIELLE SPAZIO RAGAZZI • A TOUCH OF "MEMORY" EXALTED BY THE CLASSICAL ART OF SOME STYLISH DETAILS SUCH AS THE TURNED FOOT OF THE TEXTILE BED. THIS GAME OF SHAPES AND FINISHES ENHANCE INDIVIDUAL CHOICE IN BOTH MAXIMUM SYSTEMS AND IN EMOTIONAL DETAIL, GIVE THE MEASURE OF THE DEGREE OF SPECIALIZATION OF DIELLE SPAZIO RAGAZZI PRODUCT.



PIEDINI LEGNO / WOODEN FEET

MANHATTAN



UN CONFORTEVOLE LETTO A DIVANETTO TESSILE, DOTATO DI RUOTE PER FACILI SPOSTAMENTI, PRESENTA RAFFINATI ACCOSTAMENTI CROMATICI DEI COORDINATI TESSILI • A COMFORTABLE TEXTILE SOFA BED, WITH CASTORS FOR EASY MOVEMENTS, PRESENTS REFINED COLOUR COMBINATIONS OF COORDINATED TEXTILES.

PIEDINI RUOTA Ø 18 CM / WHEEL Ø 18 CM FEET



LETTO MANHATTAN CON DUE TESTIERE E SCHIENALE / MANHATTAN BED WITH TWO HEADBOARDS WITH SLATTED BASE



MANHATTAN

IL GIROLETTO MANHATTAN PUÒ ESSERE MONTATO SU RUOTE PER FACILI SPOSTAMENTI E PUÒ ESSERE ACCOSTATO IN FORMAZIONE ANGOLARE. E' PROPOSTO NELLE VERSIONI SOMMIER OPPURE A DIVANETTO INTERAMENTE RIVESTITO IN TESSUTO O ECO-PELLE • THE BED FRAME MANHATTAN CAN BE MOUNTED ON WHEELS TO BE EASILY MOVED AND IT CAN BE PLACED CLOSE TO ANOTHER BED FORMING A CORNER. IT IS PROPOSED IN THE SOMMIER VERSION OR IN THE SOFA VERSION COMPLETELY UPHOLSTERED WITH FABRIC OR ECO-LEATHER.



LETTO MANHATTAN CON UNA TESTIERA E SCHIENALE / MANHATTAN BED WITH ONE HEADBOARD WITH SLATTED BASE

MANHATTAN

LETTI SINGOLI PER MATERASSO DA 80/90 CM SINGLE BEDS FOR MATTRESSES OF 80/90 CM.

LETTO SOMMIER MANHATTAN

LETTO IMBOTTITO SFODERABILE, RETE A DOGHE CON APERTURA A CONTENITORE.
REMOVABLE UPHOLSTERED BED, SLATTED BASE WITH STORAGE BOX OPENING.



L. 202,2 H. 35 P. 90

DIVANETTO "AD ELLE" MANHATTAN

LETTO IMBOTTITO SFODERABILE CON TESTIERA DX/SX, RETE A DOGHE CON APERTURA A CONTENITORE / REMOVABLE UPHOLSTERED BED, WITH RH/LH HEADBOARD, SLATTED BASE WITH STORAGE BOX OPENING.



L. 203 H¹. 75 H². 55
P. 90

DIVANETTO MANHATTAN

LETTO IMBOTTITO SFODERABILE CON 2 TESTIERE, RETE A DOGHE CON APERTURA A CONTENITORE.
REMOVABLE UPHOLSTERED BED WITH 2 HEADBOARDS, SLATTED BASE WITH STORAGE BOX OPENING.



L. 203 H¹. 75 H². 55
P. 90

GLI ACCESSORI / ACCESSORIES

PIEDE CILINDRO
CYLINDER
FOOT

PIEDE DISCO
DISC FOOT

RUOTA
Ø 12 CM
WHEEL Ø 12 CM

RUOTA
Ø 18 CM
WHEEL Ø 18 CM

PIEDE LEGNO
WOODEN
FOOT

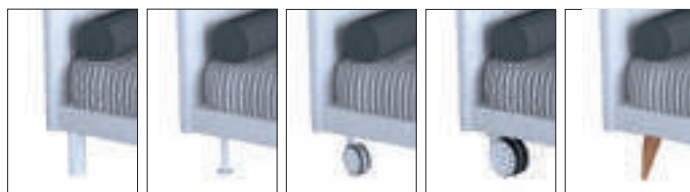

MANHATTAN È UN LETTO TESSILE DESIGN DALLE FORME ERGONOMICHE ED ESSENZIALI. PRESENTA TRE DIVERSI ALLESTIMENTI: CON RUOTE PER FACILI SPOSTAMENTI, O IN VERSIONE FISSA CON PIEDI LEGNO E CON PIEDI IN METALLO. IL RIVESTIMENTO TESSILE DISPONIBILE IN DIVERSE TONALITÀ COORDINATE ALLE FINITURE DI SISTEMA E COMPLETAMENTE SFODERABILE. • MANHATTAN IS A DESIGN UPHOLSTERED BED WITH ERGONOMIC AND ESSENTIAL SHAPES. IT IS AVAILABLE IN THREE DIFFERENT VERSIONS: WITH CASTORS FOR EASY MOVEMENT, OR IN FIXED VERSION WITH WOOD AND METAL FEET. THE FABRIC UPHOLSTERY IS AVAILABLE IN DIFFERENT COLOURS COORDINATED WITH THE SYSTEM FINISHES AND IS FULLY REMOVABLE.







LETTI SINGLE ANASTASIA, YVONNE, LOBBY, TIME

IL LETTO "SINGLE" È PROTAGONISTA DELLO SPAZIO NOTTE

ACCENTI DI "MEMORIA" ESALTATI DALLE FINITURE TESSILI O IN ESSENZA ASSOCIATE AD ARTE ALLA CLASSICITÀ DI ALCUNI DETTAGLI DI STILE COME LA GAMBA TORNITA DELLO SCRITTOIO SAGOMATO. QUESTO RAFFINATO GIOCO DI FORME E FINITURE PROPONE UN'IDEA DI HABITAT CURATO IN OGNI DETTAGLIO NEL SEGNO DI UNA PERSONALITÀ DISTINTIVA. FINITURE TATTILI AD EFFETTO MATERICO, COME LE NUOVE FINITURE IN ESSENZA OFFRONO GRADEVOLI SENSAZIONI SOFT TOUCH • THE "SINGLE" BED IS LEADING ELEMENT OF THE NIGHT AREA. ACCENTS OF "MEMORY" ENHANCED BY THE TEXTILE AND WOOD FINISHES ARTFULLY ASSOCIATED TO THE CLASSICISM OF SOME STYLISH DETAILS SUCH AS TURNED LEGS OF THE SHAPED DESK. THIS SOPHISTICATED PLAY OF SHAPES AND FINISHES PROPOSES AN IDEA OF HABITAT WITH ATTENTION TO EVERY DETAIL IN THE SIGN OF A DISTINCTIVE PERSONALITY. FINISHES WITH TACTILE EFFECT, AS THE NEW WOOD FINISHES WHICH OFFER PLEASANT SOFT TOUCH SENSATIONS.

SINGLE BEDS: ANASTASIA, YVONNE, LOBBY, TIME



ANASTASIA

LETTO / BED

LETTI PIAZZA E MEZZA
PER MATERASSO DA 120 CM
THREE-QUARTER FOR MATTRESSES OF 120 CM.

LETTO ANASTASIA

LETTO IMBOTTITO RETE A DOGHE



L. 215 H. 98
P. 145

GLI ACCESSORI / ACCESSORIES

PIEDE DRITTO PIEDE INCLINATO
STRAIGHT FOOT ANGLED FOOT



DIELLE PROPONE UNA RICCA COLLEZIONE DI LETTI PENSATI PER UN'AREA RELAX
CONFORTEVOLE E RAPPRESENTATIVA • DIELLE OFFERS A RICH COLLECTION OF BEDS DESIGNED
FOR A REPRESENTATIVE AND COMFORTABLE RELAX AREA.



YVONNE

LETTO / BED

LETTI PIAZZA E MEZZA
PER MATERASSO DA 120 CM
THREE-QUARTER FOR MATTRESSES OF 120 CM.

LETTO YVONNE

TESTIERA IMBOTTITA /
UPHOLSTERED HEADBOARD.



H

L. 215 H. 98
P. 145

CON PANNELLO
RIVESTITO IN TESSUTO /
WITH FABRIC COVERED
PANEL.



YVONNE È UN LETTO TESSILE DAL DESIGN CONTEMPORANEO CHE UNISCE LA PRATICITÀ DEL CONTENITORE APRIBILE AL COMFORT DELLA SUA MORBIDA TESTIERA. I COORDINATI TESSILI VALORIZZANO OGNI SINGOLA PROPOSTA • YVONNE IS A TEXTILE BED WITH A CONTEMPORARY DESIGN THAT COMBINES THE PRACTICALITY OF THE OPENABLE CONTAINER TO THE COMFORT OF ITS SOFT HEADBOARD. THE TEXTILE PRODUCTS ENHANCE THE VALUE OF EVERY SOLUTION.



LOBBY

LETTO / BED

LETTI PIAZZA E MEZZA
PER MATERASSO DA 120 CM
THREE-QUARTER FOR MATTRESSES OF 120 CM.









TIME
LETTO / BED

LETTI PIAZZA E MEZZA
PER MATERASSO DA 120 CM
THREE-QUARTER FOR MATTRESSES OF 120 CM.











LETTI A CASTELLO HAPPY, MERLINO

SOLUZIONI SALVASPAZIO PER OGNI ESIGENZA

DIELLE HA UNA SOLUZIONE PERFETTA PER OGNI FASE DELLA CRESCITA, DALL'INFANZIA ALL'ETÀ ADULTA, PASSANDO PER L'ADOLESCENZA. IL CASTELLO SPECIALIZZATO DIELLE È PENSATO PER SODDISFARE LE ESIGENZE DEI BAMBINI, CON PARTICOLARE ATTENZIONE AL LORO SVILUPPO E ALLA LORO SICUREZZA, LA CAMERETTA DIVENTA UNO SPAZIO MULTIFUNZIONALE DOVE RIPOSARE, GIOCARE, STUDIARE E SOCIALIZZARE • DIELE HAS THE PERFECT SOLUTION FOR ALL GROWING-UP STAGES, FROM CHILDHOOD THROUGH TO ADOLESCENCE AND ADULTHOOD. THE SPECIALISED DIELE BUNK BED HAS BEEN DESIGNED TO CATER TO THE NEEDS OF CHILDREN, WITH SPECIAL FOCUS ON GROWING UP AND SAFETY, THE CHILDREN'S BEDROOM BECOMES A MULTIFUNCTIONAL SPACE IN WHICH TO SLEEP, PLAY, STUDY AND SOCIALISE.

BUNK BEDS: HAPPY, MERLINO



CASTELLO

COMPONI IL CASTELLO CHE VUOI!

A-TESTIERE HEADBOARDS



B-ATTREZZATURE SOTTOPALCO UNDER-THE-LOFT EQUIPMENT



C-PEDANE PLATFORMS



D-SCALE LADDERS

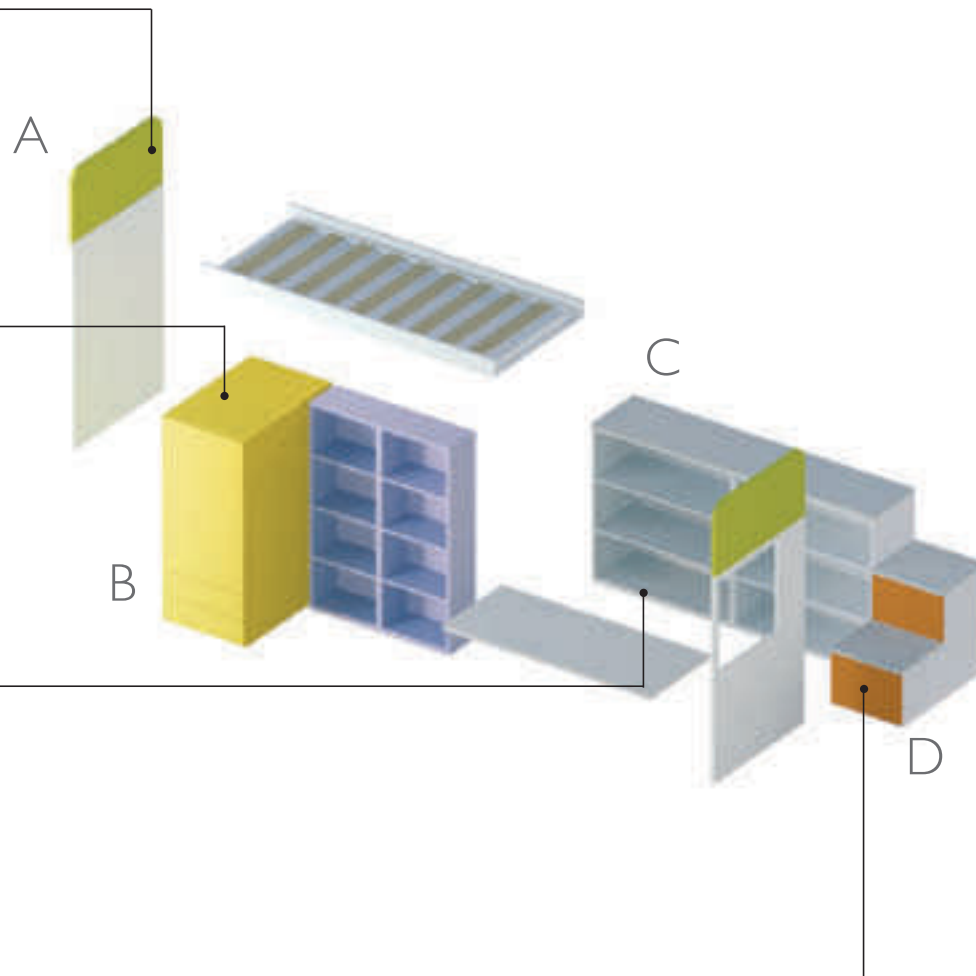

IL LETTO A CASTELLO È DIVENTATO UN PROGETTO: SI POSSONO CONFIGURARE LE ATTREZZATURE DI SALITA, LO SPAZIO SOTTOPALCO, I MODELLI DI TESTIERA. LO SPAZIO SOTTO IL LETTO DIVENTA UN LETTO FISSO, UN LETTO MOBILE, UN ARMADIO, UNA CABINA, UNA SCRIVANIA, UNA LIBRERIA, UNA ZONA STUDIO, UNA ZONA GIOCO... LA SALITA E LA PEDANA DIVENTANO CASSETTI, ANTE, GAVONI O SCAFFALATURA. UN UNICO SISTEMA PROGETTUALE METTE A DISPOSIZIONE CON SEMPLICITÀ TUTTE LE FUNZIONI IN MODO COMPATTO PRATICO E RAZIONALE • THE BUNK BED HAS BECOME A PROJECT: IT IS POSSIBLE TO CONFIGURE THE CLIMBING EQUIPMENT, THE UNDER-THE-LOFT SPACE, THE HEADBOARD MODELS. THE SPACE UNDERNEATH THE BED BECOMES A FIXED BED, A MOBILE BED, A WARDROBE, A WALK-IN CLOSET, A WRITING DESK, A BOOKCASE, A STUDY AREA, A PLAY AREA... THE CLIMB AND THE PLATFORM BECOME DRAWERS, DOORS, STORAGE CONTAINERS OR SHELVES. A SINGLE PLANNING SYSTEM PLACES ALL FUNCTIONS AT DISPOSAL WITH GREAT SIMPLICITY IN A COMPACT, PRACTICAL AND RATIONAL WAY.



HAPPY

IL CASTELLO INNOVATIVO

UNO SPAZIO DOVE CRESCERE MA ANCHE DIVERTIRSI... E DOVE NULLA È LASCIATO AL CASO! IL TRADIZIONALE LETTO A CASTELLO È RIVISITATO IN CHIAVE INNOVATIVA PER MEGLIO ADATTARSI ALLO SVILUPPO DEL BAMBINO, CON ATTENZIONE ALL'ESTETICA, AI COLORI E ALLE FINITURE CHE SONO INDISPENSABILI PER CREARE UN AMBIENTE CREATIVO E "STIMOLANTE". LA CAMERA NON SOLO COME LUOGO DI CRESCITA, MA ANCHE DI SOCIALIZZAZIONE E CONDIVISIONE • A SPACE IN WHICH TO GROW UP BUT ALSO HAVE FUN...AND WHERE NOTHING IS LEFT TO CHANCE! THE TRADITIONAL BUNK BED HAS BEEN REINTERPRETED IN AN INNOVATIVE KEY TO BETTER ADAPT TO THE CHANGES IN CHILDREN'S DEVELOPMENT, WITH FOCUS ON AESTHETICS, COLOURS AND FINISHES, ALL CRUCIAL FOR INVENTING A CREATIVE AND "STIMULATING" INTERIOR. THE BEDROOM IS NOT ONLY A PLACE FOR GROWING UP, BUT ALSO FOR SOCIALISING AND SHARING.

THE INNOVATIVE BUNK BED







HAPPY

LA SCALA DIETRO AL LETTO



THE STAIR BEHIND THE BED

IL PROGETTO RAZIONALE PENSATO APPOSITAMENTE PER IL BAMBINO, MA CON ATTENZIONE AL PERFETTO SFRUTTAMENTO DEGLI SPAZI E ALL'INTEGRAZIONE DEGLI ELEMENTI DEL "CONTENERE": ECCO CHE L'ORDINE NELLA CAMERETTA NON È PIÙ UN PROBLEMA! • THE RATIONAL PROJECT SPECIALLY CONCEIVED FOR CHILDREN, BUT WITH FOCUS ON THE PERFECT EXPLOITATION OF SPACES AND THE INTEGRATION OF THE "STORAGE" ELEMENTS: KEEPING THE CHILDREN'S ROOM TIDY IS NO LONGER A PROBLEM!



HAPPY

PIÙ DI UN SEMPLICE CASTELLO

LE CAMERE DEI RAGAZZI SONO OGGI SPAZI IPERFUNZIONALI VISSUTI A TRECENTOGRADI, DA VIVERE PIENAMENTE. DIELE INTERPRETA QUESTO TEMA PROGETTUALE E LO FA CON PERSONALITÀ DISTINTIVA. NEL SEGNO DI UNA NUOVA CREATIVITÀ. • TODAY, CHILDREN'S ROOMS ARE HYPERFUNCTIONAL SPACES TO BE EXPLOITED AND ENJOYED TO THE FULL. DIELE INTERPRETS THIS DESIGN THEME AND DOES SO WITH DISTINCTIVE PERSONALITY. ON THE BASIS OF A NEW CREATIVITY.

MORE THAN JUST A BUNK BED





MERLINO

CON PEDANA RETROLETTO

UNA PROPOSTA X CAB CABINA ARMADIO ACCOSTA UN CASTELLO MERLINO MULTIFUNZIONALE. UNA PRATICA SOLUZIONE SALVASPAZIO CHE RECUPERA, CON IL LETTO POSTO IN ALTO, DUE METRI QUADRATI DI PREZIOSO SPAZIO • AN X CAB WALK-IN CLOSET COMBINED WITH A MERLINO MULTIFUNCTIONAL BUNK BED. A PRACTICAL SPACE-SAVING SOLUTION ABLE, WITH THE HIGH-POSITIONED BED, TO RECOVER TWO SQUARE METRES OF PRECIOUS SPACE.

WITH BEHIND-THE-BED PLATFORM









PROTECTION / SOLUTION - PANNELLATURE A MURO

PROTECTION

PANNELLO IMBOTTITO A PARETE CON ISOLANTE



SOLUTION

PANNELLO NOBILITATO A PARETE



PARTICOLARE IN SEZIONE PROTECTION CROSS-SECTION DETAIL

Pannello / Panel

Materiale isolante /
Insulating material

Imbottitura / Upholstery

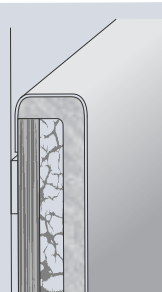

MORBIDO E ACCOGLIENTE PROTECTION È UN PANNELLO DA FISSARE A MURO, FORNITO AL METRO LINEARE IN VARIE ALTEZZE. L'UTILIZZO È QUELLO DI PROTEGGERE LA PARETE IN PROSSIMITÀ DI LETTI E DIVANI. GRAZIE AD UNO SPECIALE STRATO ISOLANTE, POSTO TRA IL TESSUTO E LA SUA ANIMA IN LEGNO, MIGLIORA IL CONFORT CONTRO FREDDO, UMIDO E RUMORE. È COMPLETAMENTE INDIPENDENTE DAL LETTO A CUI VIENE ACCOSTATO, LASCIANDO INALTERATA LA COMODITÀ DI RIASSETTO • SOFT AND COMFORTABLE, PROTECTION IS A PANEL TO BE FASTENED TO THE WALL, SUPPLIED PER LINEAR METRE IN VARIOUS HEIGHTS. THIS PANEL PROTECTS THE WALL NEAR BEDS AND DIVANS. THANKS TO A SPECIAL INSULATING LAYER BETWEEN THE FABRIC AND ITS WOOD CORE, BETTER COMFORT IS ACHIEVED AGAINST COLD, DAMP AND NOISE. THE PANEL IS COMPLETELY SEPARATE FROM THE NEARBY BED, SO MAKING UP THE BED IS NO PROBLEM.

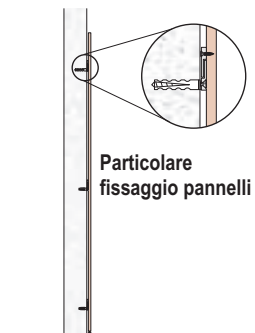

SOMMIER PER PANNELLI A MURO

MONTREAL



L. 212 H. 34
P. 97 - 107 - 137 - 177

HAVANA



L. 230 H. 32
P. 113 - 123 - 153

BALTIMORA



L. 212 H. 34
P. 97 - 107 - 137

SYDNEY



L. 203 H. 32
P. 88 - 98 - 128

MIAMI



L. 208 H. 35
P. 93

DALLAS



L. 203 H. 35
P. 90

MANHATTAN



L. 202,2 H. 35 P. 90

PANNELLI TESSILI / TEXTILE PANELS



SOLUTION

PANNELLI MELAMMINICO / MELAMINE PANELS



L'azienda, al fine di migliorare il prodotto, si riserva di apportare senza preavviso le modifiche e le migliori tecniche ritenute necessarie.

www.dielle.it

DIELLE UTILIZZA MATERIALI
ECO-COMPATIBILI NEL
RISPETTO DELLA NATURA.

DIELLE USES ECO-COMPATIBLE
MATERIALS IN RESPECT FOR NA-
TURE.

I PRODOTTI SONO REALIZZATI
CON MATERIALI E COMPONENTI DI
ALTA QUALITÀ E SONO
GARANTITI 5 ANNI.



ANNI
GARANZIA

PRODUCTS ARE MADE WITH
HIGH-QUALITY MATERIALS
AND PARTS AND COME WITH
A 5-YEARS WARRANTY.

I PRODOTTI SONO
INTERAMENTE REALIZZATI
IN ITALIA.

PRODUCTS ARE MADE
ENTIRELY IN ITALY.

R.&D./ DIELLE spa
A.D./ Promark/Comunicazione - MB-
IDEAZIONE/ Giambattista Ciceri
PHOTO/ PuntoZero
ART-BUYER/ Annalia e Greta Perego
STAMPA/ Industria Grafica S.L. - VR-

PONTI



DIELLE
GRUPPO DOIMO

DESIGN IN PROGRESS PONTI COLLECTION

- 6 | **P01** PONTE SCORREVOLE CON COLONNA SOTTOPONTE
SLIDING DOORS BRIDGE WITH CUPBOARD BELOW

- 22 | **P02** PROGETTO PONTE 4D
4D-PROJECT BRIDGE

- 36 | **P03** PONTE LINEARE BATTENTE - SCORREVOLE
LINEAR OVERHEAD CUPBOARD HINGED OR SLIDING DOORS

- 58 | **P04** PONTE IN ACCOSTAMENTO A XCAB
OVERHEAD CUPBOARD CONNECTED TO AN XCAB

- 72 | **P05** PONTE & LIBRERIA
BRIDGE & BOOKSHELF

- 88 | **P06** DOPPIO PONTE
DOUBLE BRIDGE

- 96 | **P07** PONTE & CABINE ANGOLARI
BRIDGE & CORNER CABS

- 108 | **P08** PONTE ANGOLARE CON COLONNA CONTENITORE
CORNER BRIDGE WITH CONTAINING COLUMN

- 118 | **P09** PONTE ANGOLARE COMPATTO - SCORREVOLE
COMPACT CORNER BRIDGE

- 130 | **P10** PONTE AD ANGOLO CON COLONNA MASTER
CORNER BRIDGE WITH MASTER TALL UNIT

- 138 | **P11** PONTE CON ALTEZZA MAXI
THE BRIDGE CUPBOARD WITH MAXI HEIGHT

P01 PONTE SCORREVOLE CON COLONNA SOTTOPONTE / SLIDING DOORS BRIDGE WITH CUPBOARD BELOW



8



16



20

P02 PROGETTO PONTE 4D / 4D-PROJECT BRIDGE



24



26



32

P03 PONTE LINEARE BATTENTE - SCORREVOLE / LINEAR OVERHEAD CUPBOARD HINGED OR SLIDING DOORS



38



40



44

P03 PONTE LINEARE BATTENTE - SCORREVOLE / LINEAR OVERHEAD CUPBOARD HINGED OR SLIDING DOORS



46



50



54

P04 PONTE IN ACCOSTAMENTO A XCAB / OVERHEAD CUPBOARD CONNECTED TO AN XCAB



60



62



64

P05 PONTE & LIBRERIA / BRIDGE & BOOKSHELF



76



80



82

DIELLE
GRUPPO DOIMO

P06 DOPPIO PONTE / DOUBLE BRIDGE



90



94

P07 PONTE & CABINE ANGOLARI / BRIDGE & CORNER CABS



98



100



106

P08 PONTE ANGOLARE CON COLONNA CONTENITORE / CORNER BRIDGE WITH CONTAINING COLUMN



110



112



114

P09 PONTE ANGOLARE COMPATTO / COMPACT CORNER BRIDGE

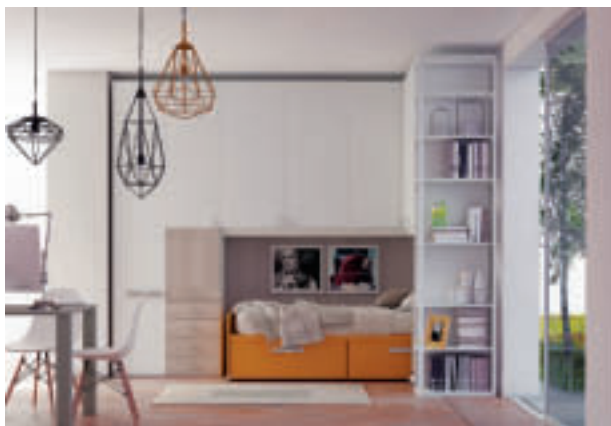

120



122



128

P10 PONTE AD ANGOLO CON COLONNA MASTER / CORNER BRIDGE WITH MASTER TALL UNIT



132



134



136

P11 PONTE CON ALTEZZA MAXI / THE BRIDGE CUPBOARD WITH MAXI HEIGHT



138



140

DIELLE
GRUPPO DOIMO



PONTE SCORREVOLE CON COLONNA SOTTOPONTE

P01

MAXI PONTE SCORREVOLE

ELEVATA CAPACITÀ DI CONTENIMENTO PER QUESTA NOTEVOLE COMPOSIZIONE A PONTE DOTATA DI ANTE SCORREVOLI • HIGH CONTAINMENT CAPABILITY FOR THIS IMPORTANT OVERHEAD COMPOSITION EQUIPPED WITH SLIDING DOORS.

CASSETTIERA PERSONALIZZABILE

LA FORMAZIONE COMPOSITIVA ANGOLARE ACCOSTA ELEMENTI BASSI LIBERAMENTE AGGREGABILI CON ANTE E CASSETTI PERSONALIZZABILI • THE CORNER COMPOSITION JOINS FREELY CONNECTABLE LOW ELEMENTS WITH CUSTOMIZABLE DRAWERS AND DOORS.

IL VANO COMODINO

LA COLONNA SOTTOPONTE PROPONE ELEMENTI DI SERVIZIO AL LETTO COME COMODINO E VANI A GIORNO-LIBRERIA • THE CUPBOARD UNDER THE OVERHEAD COMPOSITION PROPOSES USEFUL ELEMENTS FOR THE BED LIKE BEDSIDE AND OPEN SPACES-BOOKSHELF.

SLIDING DOORS BRIDGE WITH CUPBOARD BELOW





A MODERN AND FUNCTIONAL SPACE

UN PRODOTTO LUDICO, VICINO ALLA PSICOLOGIA DEI BAMBINI... INTERPRETARE PROGETTUALMENTE LO SPAZIO RAGAZZI È FACILE GRAZIE ALLA COMPONENTE DI SISTEMA ED ALLE FINITURE NOBILITATE OLMO PROPOSTO IN ACCOSTAMENTO AI RAFFINATI CROMATISMI DEI COLORI MODA. FUNZIONALITÀ, ELEGANZA E STILE PER UN AMBIENTE DA VIVERE PIENAMENTE • A PLAYFUL PRODUCT, CLOSE TO THE CHILDREN'S PSYCHOLOGY... IT'S EASY TO INTERPRET BY DESIGN THE CHILDREN'S SPACE THANKS TO THE SYSTEM MODULARITY AND TO THE ELM MELAMINE FINISHES PROPOSED IN COMBINATION WITH THE REFINED CHROMATICISMS OF THE FASHION COLOURS. FUNCTIONALITY, ELEGANCE AND STYLE FOR A SPACE TO BE FULLY LIVED.

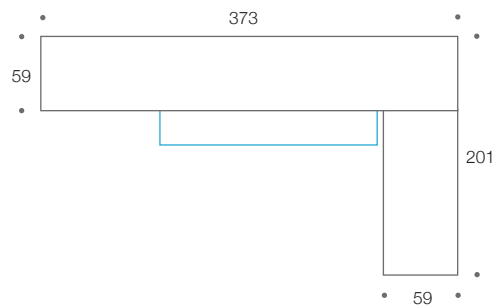

FINITURE - FINISHES (MELAMMINICI / LACCATI)
OLMO PERLA, BIANCO, CORDA2, CRETA, POLVERE.





501

TIPOLOGIE DEGLI ELEMENTI ANGOLO BASSO

ELEMENTI CON ANTA OBLÒ

LA SIMPATICA ANTA OBLÒ È UN MOTIVO GIOCOSO E DIVERTENTE DA COMPORRE A PIACERE. ANCHE IL GIOCO DELLE MANIGLIE CREA PIACEVOLI EFFETTI • ELEMENTS WITH PORTHOLE DOOR THE FRIENDLY PORTHOLE DOOR IS A FUNNY AND PLAYFUL ELEMENT TO BE COMPOSED AT WILL. ALSO, THE GAME OF THE HANDLES CREATES TASTEFUL EFFECTS.

CONFIGURARE L'ANGOLO BASSO

L'UTILIZZO DEI CASSETTI, DISPONIBILI SIA SINGOLI CHE IN DOPPIA ALTEZZA, COMBINATI CON ANTE SEMPLICI O CON 'OBLO' SI PRESTANO A MOLTE VARIABILI ESTETICHE • THE DRAWERS AS WELL, AVAILABLE IN SINGLE AND IN DOUBLE HEIGHT, COMBINED WITH SIMPLE DOORS OR WITH PORTHOLE, EMPLOYING INFINITE AESTHETIC VARIATIONS.







UN AMBIENTE INFORMALE E CREATIVO

AN INFORMAL AND CREATIVE LIVING SPACE

LA CAPIENZA DEL PONTE

FARE DI NECESSITÀ VIRTÙ... COSÌ IL PROBLEMA DELLO SPAZIO SI RISOLVE CON ELEGANZA CON UNA SOLUZIONE MAXI PONTE DOTATA DI ANTE SCORREVOLI CHE NON PRESENTANO INGOMBRO IN APERTURA • MAKE A VIRTUE OUT OF NECESSITY... THIS IS THE WAY TO SOLVE WITH ELEGANCE THE PROBLEMS OF SPACE WITH A SOLUTION OF WIDE OVERHEAD CUPBOARD COMPOSITION EQUIPPED WITH SLIDING DOORS WHICH HAVE A SPACE-SAVING OPENING.

LA TEXTURE CARBONCINO

IN FACCIATA GLI ELEMENTI DI SISTEMA SONO PERSONALIZZABILI CON GEOMETRICHE TEXTURE E STICKERS PER UN'AMBIENTE UNICO E SORPRENDENTE • THE FRONTS OF THE SYSTEM ELEMENTS ARE CUSTOMIZABLE WITH GEOMETRIC TEXTURE AND STICKERS FOR AN AMAZING AND UNIQUE AMBIANCE.

GIOCO DI NON COLORI

LE PALETTE COLORI DEL SISTEMA CROMATICO DIELLE DANNO VITA A INTERPRETAZIONI SEMPRE NUOVE • THE COLOUR PALETTES OF THE DIELLE CHROMATIC SYSTEM GIVE LIFE TO ALWAYS NEW INTERPRETATIONS.



FINITURE - FINISHES (MELAMMINICI / LACCATI)
BIANCO, CORDA2, CRETA, POLVERE. TEXTURE CARBONCINO.





502

PONTE SCORREVOLE CON COLONNA SOTTOPONTE / PLUS

P01



SLIDING DOORS BRIDGE WITH CUPBOARD BELOW / PLUS



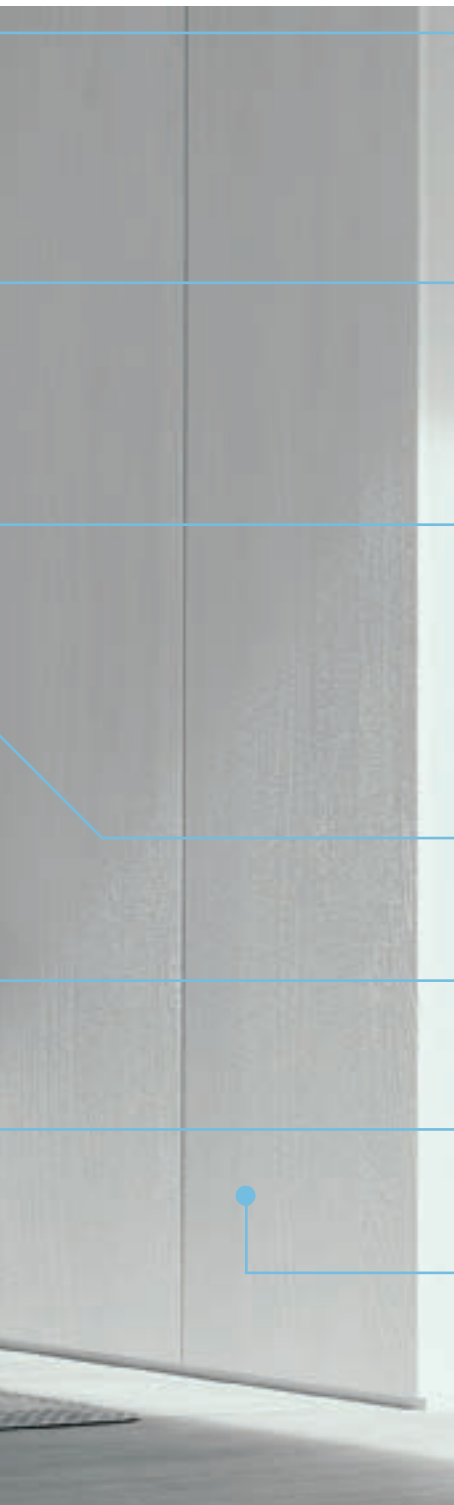

CASSETTIERA PERSONALIZZABILE / CUSTOMIZABLE DRAWER UNIT

IL GRUPPO ANGOLARE BASSO E' PERSONALIZZABILE SIA PER LE DIMENSIONI SIA PER L'UTILIZZO DEI CASSETTI. • THE LOW CORNER GROUP IS CUSTOMIZABLE IN DIMENSIONS AND IN USE OF THE DRAWERS..

MAXI PONTE SCORREVOLE / WIDE SLIDING-DOORS OVERHEAD CUPBOARD

I MAXI ELEMENTI A PONTE DOTATI DI ANTE SCORREVOLI PERSENTANO UNA CAPIENZA SUPERIORE AI NORMALI PONTI • THE MAXI OVERHEAD ELEMENTS EQUIPPED WITH SLIDING DOORS HAVE A GREATER CAPACITY THAN THE CONVENTIONAL ONES.

ZONA APPOGGIO INTEGRATA / INTEGRATED SUPPORT AREA

LA PARETE SOTTOPONTE SI PRESENTA COME UNA ZONA D'APPOGGIO INTEGRATA, UTILIZZABILE SIA COME VANO COMODINO SIA COME LIBRERIA • THE UNDER BRIDGE SPACE CAN BE USED AS AN INTEGRATED SUPPORT AREA, LIKE AS A BED-SIDE OR AS A BOOKSHELF.

BARRA PONTE NASCOSTA / HIDDEN BRIDGE SUPPORT BAR

STICKER / TEXTURE

LETTO GAMBA SFERA / BED WITH SPHERIC LEG

FINITURA MATERICA PORO APERTO / OPEN-PORE MATERIC FINISH

AN IDEAL COMPACT SOLUTION



LIBRERIA PASSANTE

SOLUZIONE A PONTE REALIZZATA CON COLONNA TERMINALE PASSANTE CON LA DUPLICE FUNZIONE DI SERVIZIO AL LETTO E ALLA SCRIVANIA • BRIDGE SOLUTION WITH ENDING OPEN TALL UNIT WITH THE DOUBLE FUNCTION OF BED'S SERVICE AND DESK.

SCRIVANIA SOTTOPONTE

SOTTO IL PONTE È RICAVATA LA GRANDE ZONA STUDIO ATTREZZATA • UNDER THE BRIDGE THERE IS A BIG EQUIPPED STUDY AREA.

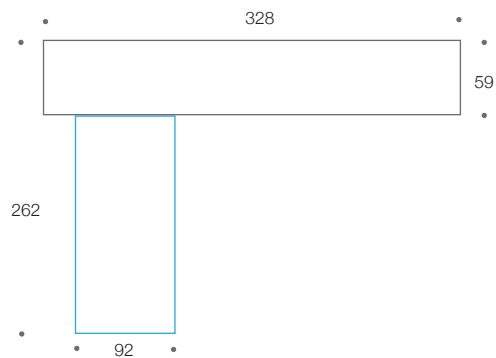

FINITURE - FINISHES (MELAMMINICI / LACCATI)
OLMO NATURALE, PETROLIO2, BIANCO, ROSSO. TEXTURE PUNTO.

UN'IDEALE SOLUZIONE COMPACT





503

DECLINARE IL PROGETTO AL FEMMINILE

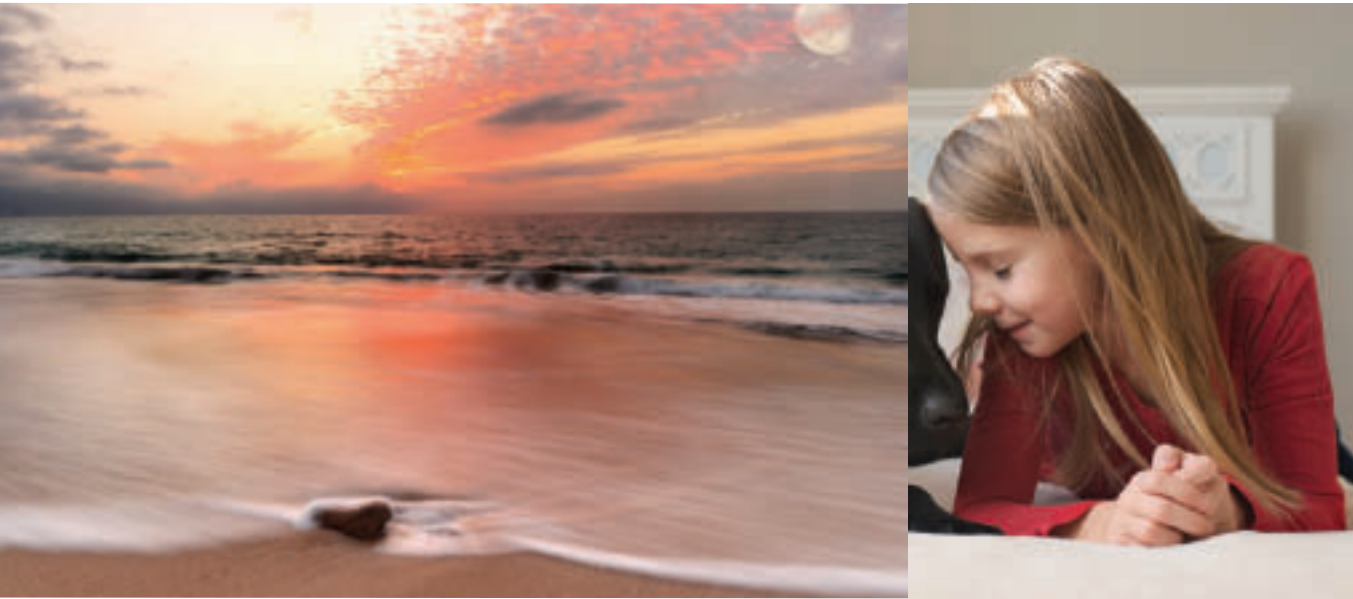

I COLORI DI GIORGIA

IL GRADO DI PERSONALIZZAZIONE È CURATO IN OGNI DETTAGLIO SIA PER LE SCELTE CROMATICHE CHE PER LE FINITURE PIÙ APPROPRIATE E DISTINTIVE • THE CUSTOMIZATION'S LEVEL IS CAREFUL IN ALL THE DETAILS FOR THE CHROMATIC CHOICES AND FOR THE MOST DISTINCTIVE AND APPROPRIATE FINISHES.

FUNZIONALE COLONNA SOTTOPONTE

IL LETTINO SOTTOPONTE È UN'IDEA PRATICA E FUNZIONALE GRAZIE ALLA COLONNA DI SERVIZIO SOTTOPONTE • THE BED PLACED BELOW THE BRIDGE IS A FUNCTIONAL AND PRACTICAL IDEA THANKS TO THE SERVICE CUPBOARD AVAILABLE.

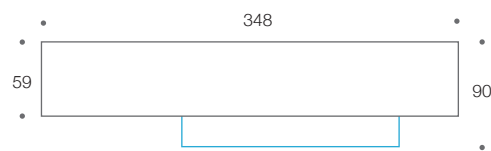

FINITURE - FINISHES (MELAMMINICI / LACCATI)
BIANCO, ROSA, ORIENTE.



504

505





GHOST / LA SCRIVANIA A SCOMPARSA

GLI ELEMENTI componibili possono essere dotati di una pratica scrivania a scomparsa. grazie alla sua dinamica si può accostare facilmente al letto • THE MODULAR ELEMENTS CAN BE EQUIPPED WITH A PRACTICAL HIDDEN DESK. THANKS TO ITS DYNAMICS IT CAN BE EASILY PLACED BESIDE THE BED.

COMPONIBILITÀ ANGOLARE

L'INTEGRAZIONE DEGLI ELEMENTI componibili consente una progettualità ideale per ogni spazio • THE MODULAR ELEMENTS INTEGRATION ALLOWS AN IDEAL PLANNING FOR EVERY LIVING SPACE.

L'ARCHITETTO... C'EST MOI

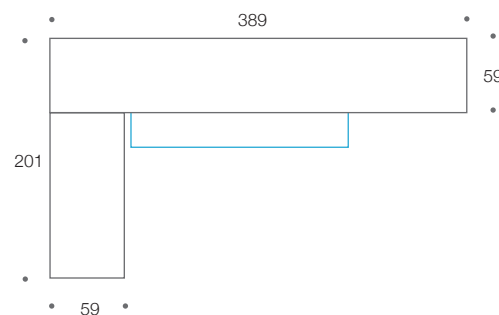

FINITURE - FINISHES (MELAMMINICI / LACCATI)
OLMO PERLA, OLMO NATURALE, CRETA.



PROGETTO PONTE 4D

P02

IL GIOCO DELLE QUATTRO PROFONDITÀ

LE SOLUZIONI PONTE DIELE SONO IL RISULTATO DEI SISTEMI COMPONIBILI INTEGRATI SPAZIO RAGAZZI • THE DIELE BRIDGE SOLUTIONS ARE THE RESULT OF THE INTEGRATED MODULAR SYSTEMS SPAZIO RAGAZZI.

LA LIBRERIA APPOGGIO RETROLETTO

LO SPAZIO SOTTOPONTE È LIBERAMENTE ORGANIZZATO CON ELEMENTI DI SERVIZIO AL LETTO • THE SPACE BELOW THE BRIDGE IS FREELY ORGANIZED WITH BOOKSHELVES AS BED SERVICE.

COLORI TONO SU TONO

LA TAVOLOZZA CROMATICA DI SISTEMA OFFRE UN AMPIO SPETTRO DI COLORI CON LE NUANCES PIÙ RICERCATE • THE SYSTEM CHROMATIC RANGE OFFERS A WIDE SPECTRUM OF COLOURS WITH THE MOST REFINED SHADES.





THE FOUR DEPTHS GAME

RICERCA DI UN NUOVO LOOK GRAFICO E INTUITIVO CON SOLUZIONI ISPIRATE AL COLORATO MONDO DEI RAGAZZI E PROIETTATE IN UNA DIMENSIONE DINAMICA E DECORATIVA. ELEMENTI A PROFONDITÀ DIFFERENZIATA ALLEGGERISCONO I VOLUMI A PARETE... COSÌ DIELLE DISEGNA IL NUOVO PONTE! PIÙ DINAMICO, PROPOSITIVO, INNOVATIVO • RESEARCH OF A NEW GRAPHIC AND INTUITIVE LOOK WITH SOLUTIONS INSPIRED TO THE YOUTH COLOURED WORLD, PROJECTED IN A DYNAMIC AND DECORATIVE DIMENSION. ELEMENTS WITH DIFFERENTIATED DEPTH LIGHTEN THE WALL VOLUMES... SO DIELLE DESIGNS THE NEW BRIDGE ! DYNAMIC, PURPOSEFUL, INNOVATIVE.

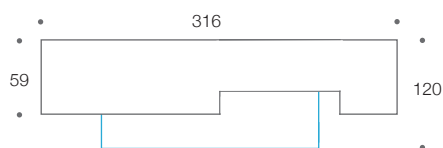

FINITURE - FINISHES (MELAMMINICI / LACCATI)
 OLMO PERLA, BIANCO, GRIGIO CHIARO, GRIGIO SCURO.





506

507



TESSUTI E FINITURE DI PERSONALITÀ

FABRICS AND FINISHES WITH PERSONALITY



STILEMI CLASSICI RIVISITATI

STILEMI CLASSICI COME LA GAMBA A TROTTOLA O IL RICCIOLO DELLA TESTIERA SONO REINTERPRETATI IN CHIAVE MODERNA • CLASSICAL STYLES LIKE THE SPIN-SHAPED LEG OR THE CURL OF THE HEADBOARD ARE PROPOSED IN A MODERN KEY.

UN GIOCO DI BIANCONERO

IL BIANCO ACCOSTA IL GRIGIO E LA TEXTURE RIGHE, IL COLORE È UTILIZZATO A CONTRASTO • THE WHITE LACQUER COMBINED WITH THE GREY AND THE "RIGA" TEXTURE, THE COLOUR HAS A CONTRASTED USE.

508

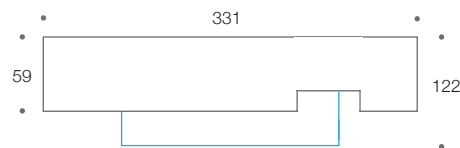

FINITURE - FINISHES (MELAMMINICI / LACCATI)
OLMO PERLA, OLMO NATURALE, CRETA, BIANCO, CANARINO.

FINITURE - FINISHES (MELAMMINICI / LACCATI)
OLMO PERLA, BIANCO, GRIGIO CHIARO, GRIGIO SCURO, TEXTURE RIGA.



IL DECORO A PARETE INTEGRATO

UN ALLEGRO CAMIONCINO

TRA GLI ELEMENTI LUDICI E GIOCOSI, AFFINI ALLA PSICOLOGIA DEI BAMBINI, SONO PROPOSTI STICKERS COLORATI E CARTE DA PARATI PER PERSONALIZZARE L'AMBIENTE GIOVANE • AMONG THE LUDIC AND PLAYFUL ELEMENTS, CLOSE TO THE KIDS' PSYCHOLOGY, COLOURED STICKERS AND WALLPAPERS ARE AVAILABLE TO CUSTOMIZE THE YOUNG AMBIANCE.



DIELLE
GRUPPO DOIMO



LUMINOSI COLORI



BRIGHT COLORS



UN SIMPATICO CAMIONCINO

DIELLE OFFRE LA POSSIBILITÀ DI PERSONALIZZARE LO SPAZIO RAGAZZI CON STICKERS E DECORI LUDICI • DIELE GIVES YOU THE CHANCE TO CUSTOMIZE THE CHILDREN'S AREA WITH STICKERS AND PLAYFUL DECORATIONS.

LETTO TESSILE ATTREZZATO

IL LETTO TESSILE È ATTREZZATO CON CASSETTO-CONTENITORE. I TESSUTI SONO COORDINATI ALLE FINITURE DI SISTEMA • THE TEXTILE BED IS EQUIPPED WITH DRAWER-CONTAINER THE FABRICS ARE COORDINATED WITH THE SYSTEM FINISHES.

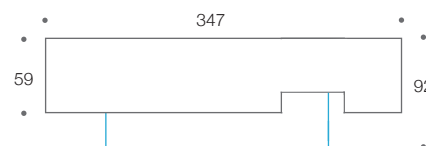

FINITURE - FINISHES (MELAMMINICI / LACCATI)
OLMO PERLA, OLMO NATURALE, CRETA, POLVERE.

509

510



PARATI E CROMATISMI



COLORIA CONTRASTO

NOTE DI COLORE PURO VENGONO ACCOSTATE AL LACCATO OPACO NEI COLORI A CAMPIONARIO E AI NOBILITATI A PORO APERTO • NOTES OF PURE COLOUR ARE MIXED WITH MATT LACQUER IN THE COLOURS OF OUR COLLECTION AND TO THE OPEN-PORE MELAMINES.

IL PONTE SIMMETRICO

UNA BILANCIATA SIMMETRIA DI ELEMENTI A PROFONDITÀ DIFFERENZIATA CARATTERIZZA QUESTE PROPOSTE LUMINOSE E SOLARI • THE BALANCED SYMMETRY OF DIFFERENT DEPTHS ELEMENTS IS THE DISTINCTIVE SIGN OF THESE BRIGHT AND SOLAR PROPOSALS.

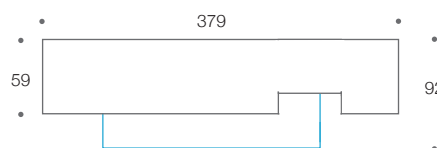

FINITURE - FINISHES (MELAMMINICI / LACCATI)
OLMO PERLA, OLMO NATURALE, CRETA, VERDE MUSCHIO.

511

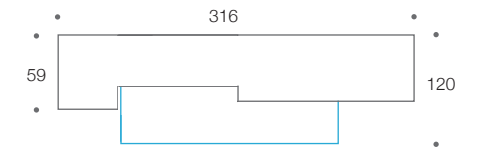

FINITURE - FINISHES (MELAMMINICI / LACCATI)
 SENAPE, ORIENTE, GRIGIO CHIARO, GRIGIO SCURO, MANDARINO, TEXTURE TRATTO.

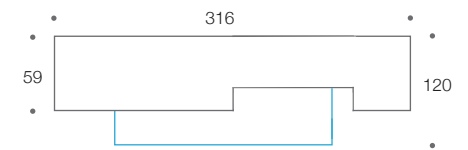

FINITURE - FINISHES (MELAMMINICI / LACCATI)
 OLMO CENERE, PRUSSIA, ZUCCA, BIANCO, GRIGIO CHIARO, GRIGIO SCURO, TEXTURE RIGA.



512



PONTE LINEARE BATTENTE SCORREVOLE

P03

PONTE ANTE BATTENTI

GLI ELEMENTI PONTE DOTATI DI ANTE BATTENTI HANNO LE MISURE GIUSTE PER ACCOGLIERE LETTI E FUNZIONI • HIGH CONTAINMENT CAPABILITY FOR THIS IMPORTANT OVERHEAD COMPOSITION EQUIPPED WITH SLIDING DOORS.

PONTE ANTE SCORREVOLI

ANCHE GLI ELEMENTI PONTE DOTATI DI ANTE SCORREVOLI PRESENTANO UNA NOTEVOLE CAPACITÀ DI CONTENIMENTO • HIGH CONTAINMENT CAPABILITY FOR THIS IMPORTANT OVERHEAD COMPOSITION EQUIPPED WITH SLIDING DOORS.

LA GRAFICA DELLE SUPERFICI

LA SCELTA DELLE FINITURE DELLE ANTE E DELLE MANIGLIE COSTITUISCE LA GRAFICA DELLE SUPERFICI • THE CHOICE OF THE DOORS' AND HANDLES' FINISHES CREATES THE SURFACES' GRAPHIC.

LINEAR OVERHEAD CUPBOARD HINGED OR SLIDING DOORS





A GREAT PERSONALITY

IL SISTEMA CROMATICO CONSENTE DI PERSONALIZZARE L'AMBIENTE CON COLORI LACCATI E FINITURE MELAMMINICO DALLE CALDE TONALITÀ DEL LEGNO, ANCHE I TESSUTI DI RIVESTIMENTO E I COORDINATI TESSILI CONTRIBUISCONO AD UN PLANNING GIOVANE E "FRESCO" • THE CHROMATIC SYSTEM ALLOWS TO CUSTOMIZE THE ROOM WITH LACQUERED COLOURS AND MELAMINE FINISHES WITH WARM WOODEN TONES. ALSO THE UPHOLSTERY FABRICS AND THE COORDINATE TEXTILES CONTRIBUTE TO A FRESH AND YOUNG PLANNING.

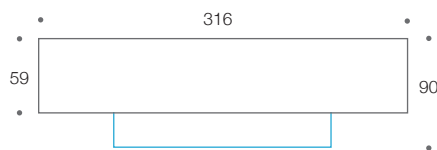

FINITURE - FINISHES (MELAMMINICI / LACCATI)
 OLMO NATURALE, OLMO PERLA, ORIENTE, FUCSIA,
 TEXTURE ARLECCHINO.





513

514





COLONNA PONTE CON COMODINO BEDSIDE

PONTE LINEARE | LINEAR OVERHEAD



BRIDGE TALL UNIT WITH BEDSIDE

DIELLE AFFRONTA IL TEMA PONTI, UN TEMA CLASSICO NELL'ARREDO DELLA ZONA NOTTE, RINNOVANDOLO CON UNO SPIRITO PROGETTUALE DI INEDITA ATTUALITÀ. IN ALTERNATIVA AL PONTE MAXI, LA RICERCA PROGETTUALE HA SVILUPPATO IL COMODINO BEDSIDE COME UNO SPECIALE VANO A GIORNO AD INCASSO, FRUIBILE DA DUE LATI E ACCOSTABILE A QUALSIASI DIMENSIONE DEL SISTEMA PONTE • DIELLE ADDRESSES THE ISSUE BRIDGES, A CLASSICAL ISSUE FURNISHING THE NIGHT AREA, RENEWING IT WITH AN ESPECIAL PROJECT SPIRIT OF ACTUALITY. AS AN ALTERNATIVE TO THE MAXI BRIDGE, THE PROJECT RESEARCH HAS DEVELOPED THE NIGHT TABLE BEDSIDE AS AN ESPECIAL BUILT-IN OPEN SPACE, USEFUL FROM THE TWO SIDES AND CONNECTABLE TO ANY DIMENSION OF THE BRIDGE SYSTEM.

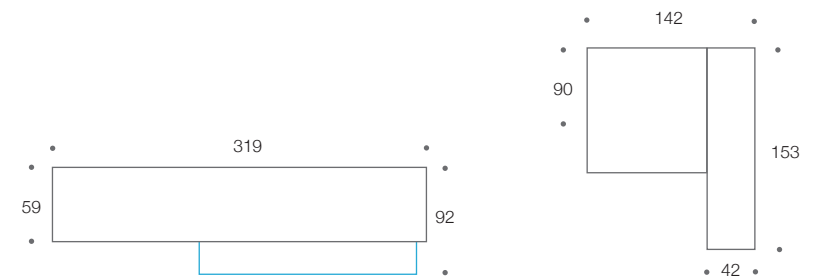

FINITURE - FINISHES (MELAMMINICI / LACCATI)
 CRETA, BIANCO, ROSA, FUCSIA, ORIENTE, GIRASOLE.
 TEXTURE PUNTO.

COLOR ... YOUR LIFE!



COLORATEVI... LA VITA!

I LETTI PERSONALIZZATI

DIELLE PROPONE UN'AMPIA GAMMA DI LETTI PENSATI PER L'AREA RAGAZZI. SI POSSONO PERSONALIZZARE CON I COLORI DEL SISTEMA CROMATICO, UTILIZZARE IL NOBILITATO "LEGNO" OPPURE SCEGLIERE TRA LE TESTIERE CREATIVE. • DIELLE PROPOSES A WIDE RANGE OF BEDS CREATED FOR THE CHILDREN AREA. THEY CAN BE CUSTOMIZED WITH THE COLOURS OF THE CHROMATIC SYSTEM, WITH THE WOOD-FINISH MELAMINES OR CHOOSING AMONG THE CREATIVE HEADBOARDS.

LE MANIGLIE COME SEGNO GRAFICO

ANCHE LE MANIGLIE, COLORATISSIME, SONO UN'OCCASIONE PER "DISEGNARE" LE FACCIATE. FORME GEOMETRICHE ESSENZIALI PUNTEGGIANO RITMICAMENTE LE SUPERFICI. • ALSO THE EXTRA COLOURED HANDLES ARE A CHANCE TO "DRAW" THE FRONTS, ESSENTIAL GEOMETRICAL SHAPES HIGHLIGHT RITHMICALLY THE SURFACES.

DIELLE
GRUPPO DOMO



515





LETTI D'ANGOLO E ZONA STUDIO ATTREZZATA

PONTE LINEARE | LINEAR OVERHEAD



L-SHAPED BEDS AND EQUIPPED STUDY ZONE

SOCIALIZZARE, RICEVERE AMICI, ANGOLO CONVERSAZIONE, STUDIO... SONO LE ATTIVITÀ DEL LIVING MODERNO IMPRONTATO AD UN UTILIZZO TOTALE E MULTIFUNZIONALE DELLA CAMERA DEI RAGAZZI. UN'IDEA VENTIQUEATTRORE CHE VEDE L'AREA LETTO-DIVANO PROTAGONISTA DEL VIVERE CONTEMPORANEO • SOCIALISING, RECEIVING FRIENDS, CONVERSATION CORNER, STUDY AREA.... THESE ARE THE ACTIVITIES OF THE MODERN LIVING AREA FOCUSED ON A TOTAL AND MULTIFUNCTIONAL USE OF THE CHILDREN'S ROOM. A TWENTY-FOUR HOURS IDEA WHICH SEES THE DIVAN-BED AREA PROTAGONIST OF THE CONTEMPORARY LIVING.

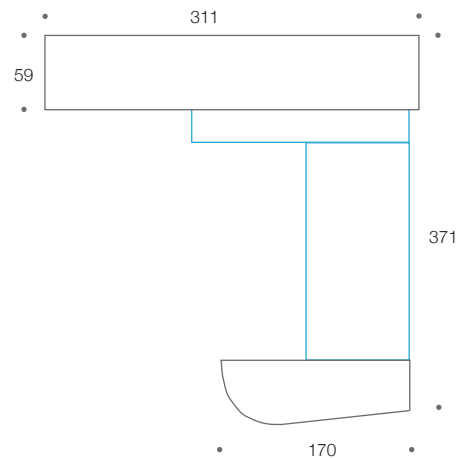

FINITURE - FINISHES (MELAMMINICI / LACCATI)
OLMO PERLA, BIANCO, PISTACCHIO.



THE SNAKE BOOKSHELF AS A TRADE UNION

SNAKE SI COMPONE "COME UN LEGO" PER FACILI ACCOSTAMENTI CROMATICI E GIOCHI DI FINITURE IN ESSENZA. BASTA QUALCHE BILANCIATO ELEMENTO PER RENDERE UNA PARETE BEN ORGANIZZATA E FUNZIONALE. SNAKE È IL COMPLEMENTO SEMPLICE E IDEALE PER OGNI ZONA STUDIO, UN PRODOTTO COMPONIBILE, IMMEDIATO ED INTUITIVO, ALTERNATIVO ALL'IMPIEGO DI ELABORATE COMPOSIZIONI LIBRERIA. • SNAKE COMPOSES "LIKE A LEGO" FOR EASY COLOUR COMBINATIONS AND GAMES OF WOOD FINISHES. JUST SOME BALANCED ELEMENT TO MAKE A WELL ORGANIZED AND FUNCTIONAL WALL. SNAKE IS THE SIMPLE AND PERFECT COMPLEMENT FOR EACH STUDY AREA, A MODULAR PRODUCT, IMMEDIATE AND INTUITIVE ALTERNATIVE TO THE USE OF ELABORATE BOOKSHELF COMPOSITIONS.

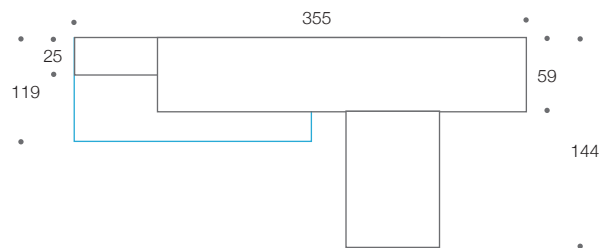

FINITURE - FINISHES (MELAMMINICI / LACCATI)
 OLMO PERLA, GRIGIO SCURO, PETROLIO2, GIRASOLE, GRIGIO CHIARO.
 TEXTURE ARLECCHINO, RIGA..

LA LIBRERIA SNAKE COME TRADE UNION





516



517



IL PONTE COL PIANO SCRIVANIA INTEGRATO

PONTE LINEARE | LINEAR OVERHEAD



THE BRIDGE WITH AN INTEGRATED DESK

UNA COMPOSIZIONE PONTE CON LE DIMENSIONI IDEALI PER ACCOGLIERE UN ATTREZZATO SCRITTOIO DI FORTE SPESSORE, UN LETTO-DIVANO TESSILE ESTERNO, UNA LIBRERIA STRUTTURALE DI VALIDO SERVIZIO. LA PERFETTA INTEGRAZIONE DI QUESTI ELEMENTI DANNO ORIGINE AD UNO SPAZIO AD ALTA FUNZIONALITÀ • AN IDEAL SETTING FOR A BOY INTO ADULTHOOD IS REPRESENTED BY THIS BRIDGE COMPOSITION WITH THE IDEAL SIZE TO ACCOMMODATE A WRITING DESK EQUIPPED THICK, A TEXTILE BED-SOFA EXTREMELY COMFORTABLE, A LIBRARY OF STRUCTURAL VALUABLE SERVICE. THE MULTI-FUNCTIONALITY AND SEAMLESS INTEGRATION OF THESE ELEMENTS GIVES RISE TO A SPACE WITH HIGH FUNCTIONALITY.

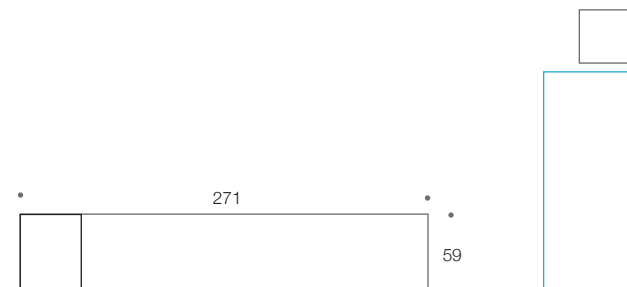

FINITURE - FINISHES (MELAMMINICI / LACCATI)
CORDA2, BIANCO.

518



ESSENZE E COLORI LACCATO OPACO



I NOBILITATI OLMO A PORO APERTO

TRA LE FINITURE DI SISTEMA DIELLE PROPONE IL NOBILITATO OLMO A PORO APERTO NELLE VERSIONI: PERLA, NATURALE E CENERE • AMONG THE SYSTEM FINISHES DIELLE PROPOSES THE OPEN-PORE ELM FINISHES IN THE VERSIONS: PERLA, NATURALE E CENERE.

COLORI PURI A CONTRASTO

UN TOCCO DI COLORE AD HOC PERSONALIZZA L'AMBIENTE NEL SEGNO DI UNA PERSONALITÀ DISTINTIVA • A PERFECT TOUCH OF COLOUR CUSTOMIZES THE ROOM IN THE SIGN OF A DISTINCTIVE PERSONALITY.

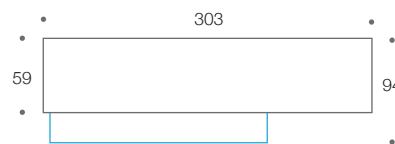

FINITURE - FINISHES (MELAMMINICI / LACCATI)
OLMO NATURALE, BIANCO, GRIGIO SCURO, ZUCCA.



COLONNA ARMADIO PROFONDITÀ CM 90

THE 90 CM DEEP CUPBOARD



519

LE TEXTURE CON UNA NUOVA GRAFICA

SONO PROPOSTE NUOVE, COLORATISSIME TEXTURE GRAFICHE CHE AFFIANCANO LE COLLAUDATE "RIGA" E "PUNTO". • ARE PROPOSED NEW COLOURFUL GRAPHIC TEXTURES ALONGSIDE TO THE WELL TESTED "RIGA" E "PUNTO".

COPPIA DI LETTI ARCHIMEDE SUBITO PRONTI

I LETTI SOVRAPPOSTI ARCHIMEDE SONO SUBITO PRONTI. QUESTE SOLUZIONI CONSENTONO DI OTTIMIZZARE DUE METRI QUADRI DI SPAZIO • THE BUNK BED ARCHIMEDE ARE READY TO USE. THESE SOLUTIONS ALLOW TO OPTIMIZE TWO SQUARE METERS SPACE.

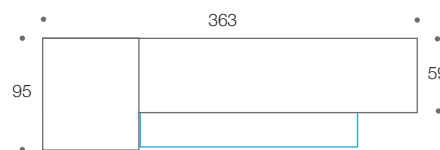

FINITURE - FINISHES (MELAMMINICI / LACCATI)
OLMO PERLA, OLMO NATURALE, GIRASOLE, ORIENTE. TEXTURE TRATTO.



520



PONTE lunghezza MAXI cm 252

UN GRANDE SPAZIO SOTTO PONTE

GLI ELEMENTI COMPONIBILI CREANO UN GRANDE SPAZIO SOTTO-PONTE ATTERZZATO IN GRADO DI ALLOGGIARE UN LETTO LONGITUDINALE E UN COMODINO IN APPOGGIO • THE MODULAR ELEMENTS CREATE A LARGE EQUIPPED AREA UNDER THE BRIDGE, IDEAL FOR A LONGITUDINAL BED AND A BEDSIDE TABLE.

LO SPAZIO PER IL LETTO E PER IL COMODINO

L'INTEGRAZIONE DEGLI ELEMENTI COMPONIBILI CONSENTE UNA PROGETTUALITÀ IDEALE PER OGNI SPAZIO • THE MODULAR ELEMENTS INTEGRATION ALLOWS AN IDEAL PLANNING FOR EVERY LIVING SPACE.

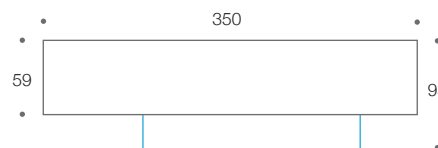

FINITURE - FINISHES (MELAMMINICI / LACCATI)
OLMO NATURALE, BIANCO, CRETA, NUVOLA.



WIDE BRIDGE cm 252 / TWO BEDS AND A BEDSIDE

I LETTI "GEMELLARI" POSSONO ESSERE INTERPRETATI UTILIZZANDO COLORI DIVERSI STUDIATI PER VALORIZZARE L'AREA RIPOSO-SOCIALIZAZIONE DOVE LE FUNZIONI INTORNO AL LETTO DEVONO ESSERE COMODE E PRATICHE NEL LORO UTILIZZO QUOTIDIANO • THE "TWIN" BEDS CAN BE INTERPRETED USING DIFFERENT COLOURS SPECIFICALLY STUDIED TO ENHANCE THE RESTING-SOCIALIZING AREA IN WHICH THE FUNCTIONS AROUND THE BED HAVE TO BE COMFORTABLE AND PRACTICAL IN THEIR DAILY USE.

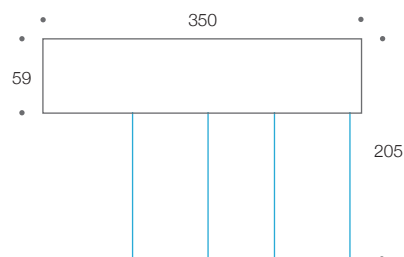

FINITURE - FINISHES (MELAMMINICI / LACCATI)
OLMO PERLA, CRETA, NUVOLO, ORIENTE.



521



PONTE IN ACCOSTAMENTO A XCAB P04

LA CABINA ARMADIO

ELEVATA CAPACITÀ DI CONTENIMENTO PER QUESTA NOTEVOLE COMPOSIZIONE A PONTE DOTATA DI ANTE SCORREVOLI • HIGH CONTAINMENT CAPABILITY FOR THIS IMPORTANT OVERHEAD COMPOSITION EQUIPPED WITH SLIDING DOORS.

LO STICKER

PERSONALIZZARE CON GLI STICKERS È FACILE E SORPRENDENTE... DIVERSI SOGGETTI PER UNO STILE UNICO • TO CUSTOMIZE WITH STICKERS IS EASY AND SURPRISING... DIFFERENT SUBJECTS FOR A UNIQUE STYLE.

LA COLONNA TERMINALE PER PONTE

LA COLONNA PER PONTE PROPONE ELEMENTI DI SERVIZIO AL LETTO COME COMODINO E VANI A GIORNO-LIBRERIA • THE BRIDGE COLUMN IS EQUIPPED WITH NIGHT TABLES AND OPEN COMPARTMENTS-BOOKSHELVES.

OVERHEAD CUPBOARD CONNECTED TO AN XCAB





THE WARDROBE CAB

GLI ELEMENTI "PONTE" POSSONO ESSERE ACCOSTATI ALLA CABINA ARMADIO PROFONDITÀ CM 95 CHE ACCOGLIE TUTTA LA PROFONDITÀ DEL LETTO. ASSOCIARE IL MELAMMINICO ESSENZA AL LACCATO É SICURAMENTE UNA SCELTA VINCENTE • THE "BRIDGE" ELEMENTS CAN BE CONNECTED TO THE 95 CM DEEP WARDROBE CAB IN THE SAME BED'S DEPTH, ASSOCIATING THE WOOD-FINISH MELAMINE TO THE LACQUERED IS CERTAINLY A WINNING CHOICE.

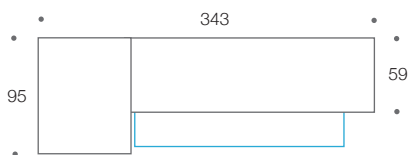

FINITURE - FINISHES (MELAMMINICI / LACCATI)
OLMO NATURALE, BIANCO, CRETA.





522





LO STICKER... ARREDA!

523

IL NUOVO LETTO DESIGN

LA COLLEZIONE LETTI DIELE PROPONE SOLUZIONI DAL DESIGN INNOVATIVO PER UN HABITAT CONTEMPORANEO • THE DIELE NEW BED COLLECTION OFFERS SOLUTIONS WITH AN INNOVATIVE DESIGN FOR A CONTEMPORARY HABITAT

LA LIBRERIA DI SERVIZIO AL LETTO

LA LIBRERIA TERMINALE È UN ELEMENTO DEL SISTEMA MASTER CHE NE CARATTERIZZA L'IMMAGINE • THE ENDING BOOKSHELF IS A MASTER SYSTEM ELEMENT CHARACTERIZING THE WHOLE IMAGE.

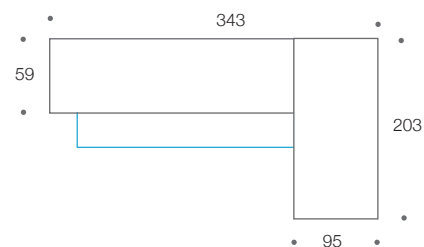

FINITURE - FINISHES (MELAMMINICI / LACCATI)
OLMO PERLA, OLMO CENERE, BIANCO, CRETA.



THE INTEGRATED BOOKSHELF

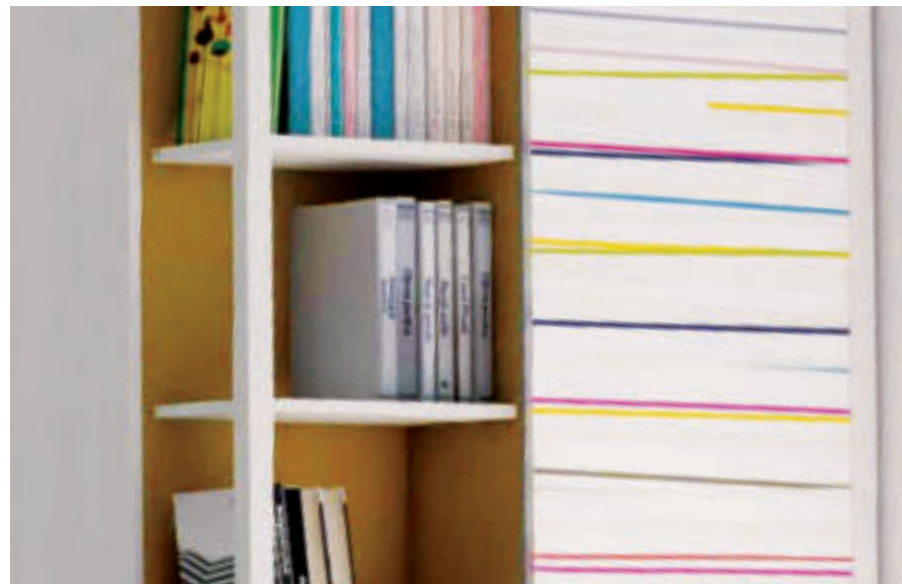

LA LIBRERIA INTEGRATA

524

IL TERMINALE CON ANTA E LIBRERIA

IL PRATICO TERMINALE PALO ALTO CON ANTA TEXTURE IDENTIFICA LE PROPOSTE DIELE. • THE PRACTICAL ENDING ELEMENT PALO ALTO WITH TEXTURE DOOR IDENTIFY THE DIELE PROPOSALS.

ELEMENTO A GIORNO SOTTOPONTE

SOTTOPONTE UN FUNZIONALE ELEMENTO A GIORNO CREA UN SERVIZIO INTORNO AL LETTO. • UNDER THE BRIDGE A FUNCTIONAL OPEN ELEMENT CREATES A SERVICE AROUND THE BED.

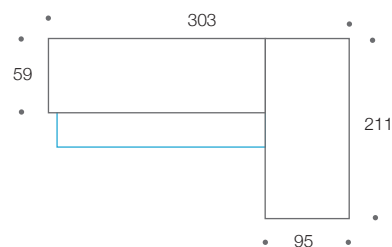

FINITURE - FINISHES (MELAMMINICI / LACCATI)
OLMO CENERE, OLMO PERLA, POLVERE, CORDA2, SENAPE.
TEXTURETRATTO.



OPEN BRIDGE SIDE

FIANCO PONTE APERTO

LA SOLUZIONE A FIANCO PONTE APERTO AUMENTA LA FRUIBILITÀ DELLO SPAZIO SOTTOPONTE PER UNA MAGGIORE LIBERTÀ DI MOVIMENTO • THE SOLUTION OF THE BRIDGE OPEN SIDE INCREASES THE USABILITY OF THE SPACE BELOW FOR A GREATER MOVEMENT FREEDOM.

LIBRERIA TERMINALE

NON UN BANALE FIANCO DI FINITURA, MA UN TERMINALE POLIFUNZIONALE DAL DESIGN INNOVATIVO • NOT A BANAL FINISHING SIDE, BUT A MULTIFUNCTIONAL ENDING ELEMENT WITH AN INNOVATIVE DESIGN.

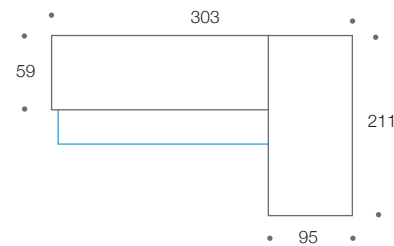

FINITURE - FINISHES (MELAMMINICI / LACCATI)
OLMO CENERE, OLMO PERLA, POLVERE, CORDA2, SENAPE
TEXTURETRATTO.



524



A HIGH PROJECT LEVEL

UN PRODOTTO LUDICO, VICINO ALLA PSICOLOGIA DEI BAMBINI... INTERPRETARE PROGETTUALMENTE LO SPAZIO RAGAZZI È FACILE GRAZIE ALLA COMPONIBILITÀ DI SISTEMA ED ALLE FINITURE NOBILITATO OLMO PROPOSTO IN ACCOSTAMENTO AI RAFFINATI CROMATISMI DEI COLORI MODA. FUNZIONALITÀ, ELEGANZA E STILE PER UN AMBIENTE DA VIVERE PIENAMENTE • A PLAYFUL PRODUCT, CLOSE TO THE CHILDREN'S PSYCHOLOGY... IT'S EASY TO INTERPRET BY DESIGN THE CHILDREN'S SPACE THANKS TO THE SYSTEM MODULARITY AND TO THE ELM MELAMINE FINISHES PROPOSED IN COMBINATION WITH THE REFINED CHROMATICISMS OF THE FASHION COLOURS. FUNCTIONALITY, ELEGANCE AND STYLE FOR A SPACE TO BE FULLY LIVED.

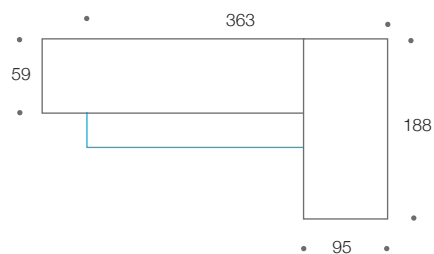

FINITURE - FINISHES (MELAMMINICI / LACCATI)
 OLMO PERLA, SENAPE, MANDARINO, CANAPA, MOKA. TEXTURE ARLECCHINO.



526

PONTE ACCOSTATO ALLA CABINA ARMADIO XCAB / PLUS

P04



OVERHEAD CUPBOARD CONNECTED TO AN XCAB / PLUS





XCAB / MAXI CABINA ARMADIO **XCAB / MAXI CUPBOARD CAB**

INTEGRAZIONE TRA ELEMENTI PONTE ED ELEMENTI CABINE ARMADIO XCAB PROFONDITÀ CM 95 • INTEGRATION AMONG BRIDGE ELEMENTS AND XCAB WARDROBE 95 CM DEEP ELEMENTS.

ANTE SCORREVOLI BICOLORE **TWO-TONE SLIDING DOORS**

LE GRANDI ANTE SCORREVOLI DEGLI ELEMENTI PONTE POSSONO ESSERE REALIZZATE BICOLORI OPPURE ESSENZA-COLORE • THE BIG SLIDING DOORS AND THE BRIDGE ELEMENTS CAN BE PRODUCED IN TWO-TONES OR WOOD-FINISH/COLOUR.

LIBRERIA “PALO ALTO” / BOOKSHELF “PALO ALTO”

GLI ELEMENTI DELLA LIBRERIA PALO ALTO UTILIZZATI COME ELEMENTI TERMINALI A GIORNO E CONTENITORE VERTICALE • THE PALO ALTO BOOKCASE USED AS VERTICAL OPEN AND CONTAINING ENDING ELEMENTS.

TEXTURE ARLECCHINO / TEXTURE ARLECCHINO

LA COLORATISSIMA TEXTURE ARLECCHINO RALLEGRA LO SPAZIO RAGAZZI CON ACCESI COLORI • THE COLORFUL TEXTURE “ARLECCHINO” CHEERS UP THE CHILDREN AREA WITH BRIGHT COLOURS.

LO STICKER / THE STICKER

LO STICKER È UN ALTRO ELEMENTO DECORATIVO DAL CARATTERE ALLEGRO E GIOCOLO • THE STICKER IS ANOTHER DECORATING ELEMENT WITH CHEERFUL AND PLAYFUL CHARACTER.

LETTO TESSILE CONTENITORE **TEXTILE BED WITH CONTAINMENT**

LETTO SPACE SAVING CON CONTENITORE APRIBILE IN SENSO LONGITUDINALE. UNA VALIDA RISPOSTA ALLA MANCANZA DI SPAZIO • SPACE SAVING BED WITH OPENABLE CONTAINER LONGITUDINALLY, AN EFFICIENT RESPONSE TO THE LACK OF SPACE .



PONTE & LIBRERIA

P05

LA LIBRERIA SOTTOPONTE

LA LIBRERIA SOTTOPONTE CREA DUE SPAZI SEPARATI CON LA GIUSTA PRIVACY PER DUE RAGAZZI • HIGH CONTAINMENT CAPABILITY FOR THIS IMPORTANT OVERHEAD COMPOSITION EQUIPPED WITH SLIDING DOORS.

DIVIDERE E UNIRE

LA LIBRERIA PASSANTE DIVIDE E UNISCE AL TEMPO STESSO L'AREA RIPOSO CON DUE LETTI ACCOSTATI • THE CORNER COMPOSITION JOINS FREELY CONNECTABLE LOW ELEMENTS WITH CUSTOMIZABLE DRAWERS AND DOORS.

CONTINUITÀ DI SPAZIO E FUNZIONE

LA LIBRERIA SOTTOPONTE PROPONE ELEMENTI DI SERVIZIO AL LETTO COME COMODINO E VANI A GIORNO-LIBRERIA • THE BOOKSHELVES UNDER THE OVERHEAD COMPOSITION PROPOSES USEFUL ELEMENTS FOR THE BED LIKE BEDSIDE AND OPEN SPACES-BOOKSHELF.

BRIDGE & BOOKSHELF



UNA SOLUZIONE PER DUE



LA LIBRERIA DIVIDE E UNISCE

IL GRADO DI PERSONALIZZAZIONE È CURATO IN OGNI DETTAGLIO SIA PER LE SCELTE CROMATICHE CHE PER LE FINITURE PIÙ APPROPRIATE E DISTINTIVE • THE CUSTOMIZATION'S LEVEL IS CAREFUL IN ALL THE DETAILS FOR THE CHROMATIC CHOICES AND FOR THE MOST DISTINCTIVE AND APPROPRIATE FINISHES.

AD OGNUNO LA PROPRIA PRIVACY

IL LETTINO SOTTOPONTE È UN'IDEA PRATICA E FUNZIONALE GRAZIE ALLA COLONNA DI SERVIZIO SOTTOPONTE • THE BED PLACED BELOW THE BRIDGE IS A FUNCTIONAL AND PRACTICAL IDEA THANKS TO THE SERVICE CUPBOARD AVAILABLE.

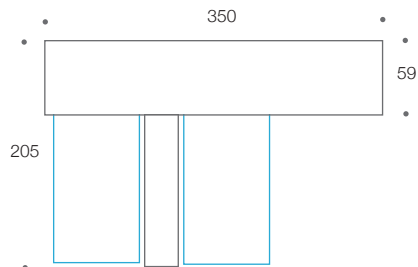

FINITURE - FINISHES (MELAMMINICI / LACCATI)
OLMO PERLA, OLMO NATURALE, CORDAZ, CRETA.





527



528

SPAZIO FORMA E FUNZIONE

SPACE SHAPE AND FUNCTION



529

LA LIBRERIA DIVIDE E UNISCE

IL GRADO DI PERSONALIZZAZIONE È CURATO IN OGNI DETTAGLIO SIA PER LE SCELTE CROMATICHE CHE PER LE FINITURE PIÙ APPROPRIATE E DISTINTIVE • THE LEVEL OF CUSTOMIZATION IS WELL-FINISHED IN EVERY DETAIL, BOTH THE CHROMATIC SELECTION AND THE MOST DISTINCTIVE AND APPROPRIATE FINISHES.

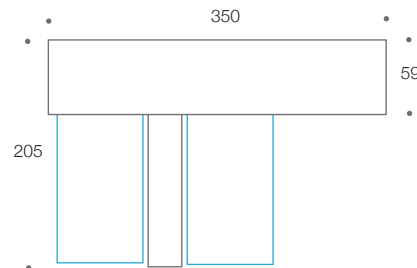

FINITURE - FINISHES (MELAMMINICI / LACCATI)
OLMO NATURALE, GRIGIO SCURO, SENAPE, SALVIA, CRETA.

FINITURE - FINISHES (MELAMMINICI / LACCATI)
OLMO PERLA, OLMO NATURALE, ALABASTRO, PISTACCHIO, CRETA.

CREARE UN DIVISORIO



LA LIBRERIA SEPARA GLI AMBIENTI

LA LIBRERIA PALO ALTO VERSIONE INTERPARETE SEPARA UNA ZONA DALL'ALTRA CREANDO NUOVE PROSPETTIVE D'ARREDO • THE PALO ALTO BOOKCASE IN DOUBLE-SIDED VERSION DIVIDES TWO ZONES CREATING NEW FURNITURE PROSPECTS.

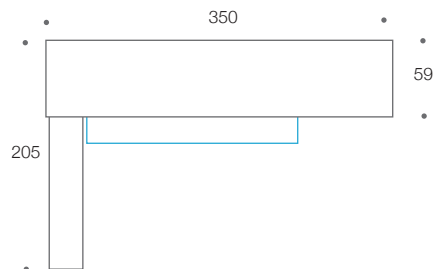

FINITURE - FINISHES (MELAMMINICI / LACCATI)
OLMO PERLA, OLMO NATURALE, POLVERE, CRETA.

CREATING A PARTITION WALL





530

531



LA LIBRERIA COME RETRO LETTO



THE BOOKSHELF AS THE BACKSIDE OF THE BED



IL RIPOSO, LO STUDIO... E IL CONTENERE

IL GRADO DI PERSONALIZZAZIONE È CURATO IN OGNI DETTAGLIO SIA PER LE SCELTE CROMATICHE CHE PER LE FINITURE PIÙ APPROPRIATE E DISTINTIVE • THE LEVEL OF CUSTOMIZATION IS WELL-FINISHED IN EVERY DETAIL, BOTH THE CHROMATIC SELECTION AND THE MOST DISTINCTIVE AND APPROPRIATE FINISHES.

LA PARETE MULTIFUNZIONE

IL LETTINO SOTTOPONTE È UN'IDEA PRATICA E FUNZIONALE GRAZIE ALLA COLONNA DI SERVIZIO SOTTOPONTE • THE UNDER-BRIDGE BED IS A HANDY AND FUNCTIONAL IDEA, THANKS TO THE UNDER-BRIDGE SERVICE COLUMN.

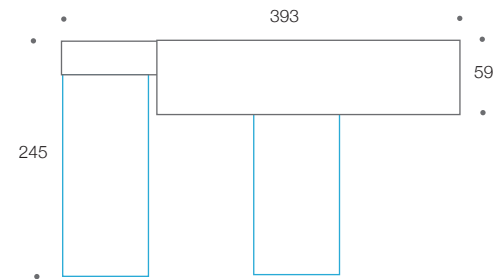

FINITURE - FINISHES (MELAMMINICI / LACCATI)
OLMO PERLA, CANAPA, NUVOLA.

LA GRANDE SCRIVANIA SOTTOPONTE



LA GRANDE SCRIVANIA ACCOSTATA ALLA LIBRERIA
 LA LIBRERIA PALO ALTO, INTEGRATA ALLA COMPOSIZIONE PONTE, ACCOGLIE UN GRANDE PIANO LAVORO E ACCOSTA IL LETTO PERPENDICOLARE • THE BIG WRITING DESK BESIDE THE PALO ALTO BOOKCASE, INTEGRATED TO THE BRIDGE COMPOSITION, INCLUDES A WIDE WORKING DESK AND APPROACHES THE BED PERPENDICULARLY.

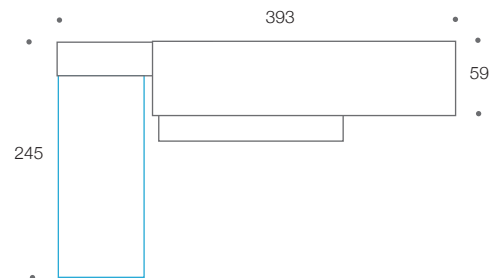

FINITURE - FINISHES (MELAMMINICI / LACCATI)
 OLMO PERLA, CANAPA, CANARINO.

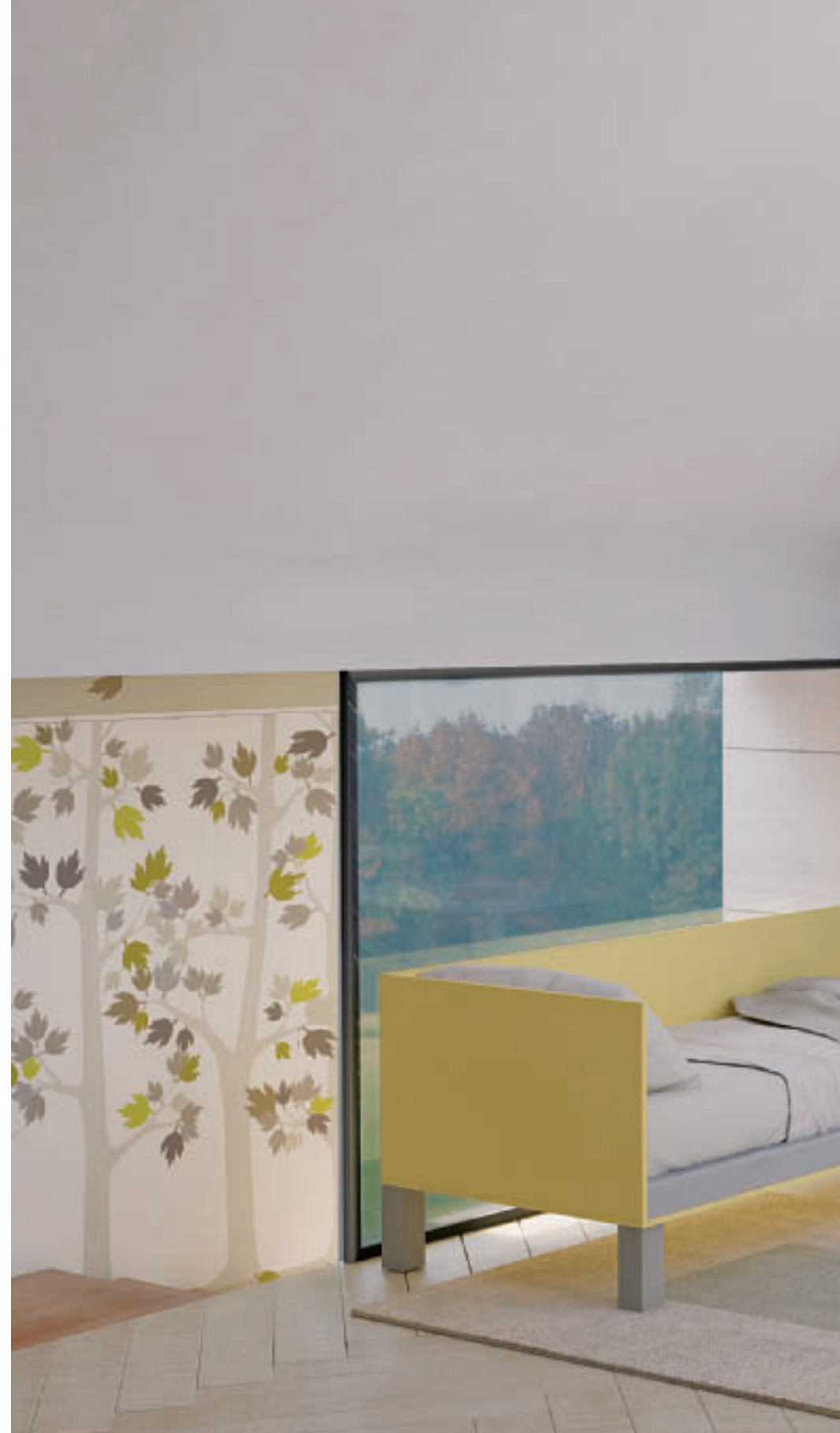



532

INTEGRARE IL PONTE CON LA LIBRERIA PALO ALTO

LA LIBRERIA ACCOSTA DUE LETTI

LA LEGGEREZZA È UNO DEI PLUS DISTINTIVI DELLA LIBRERIA PALO. UNA SOLIDA STRUTTURA CONSERVA TUTTA LA SUA LEGGEREZZA GRAZIE ALL'ASSENZA DI FIANCHI PORTANTI • LIGHTNESS IS ONE OF THE DISTINCTIVE FEATURES OF THE PALO BOOKSHELF. A SOLID STRUCTURE KEEPS ALL ITS LIGHTNESS DUE TO THE ABSENCE OF SUPPORTING SIDES

UN GRANDE PIANO DI LAVORO

LA LIBRERIA PALO È VALORIZZATA NELLE VERSIONI NOBILITATO OLMO PROPOSTE NELLE VARIANTI OLMO PERLA, OLMO NATURALE E OLMO CENERE • THE PALO BOOKSHELF IS VALORIZED IN ENNOBLED ELM VERSIONS, WHICH ARE PROPOSED IN THE VARIATIONS OF PEARL ELM, NATURAL ELM AND ASH-COLOURED ELM.



IL LETTO LONGITUDINALE, LA SCRIVANIA PERPENDICOLARE
ALLA LIBRERIA PALO PUÒ ESSERE ACCOSTATO UN LETTO OPPURE
UNA SCRIVANIA AUMENTANDO LA FUNZIONALITÀ DEL PRODOTTO
• A BED OR A DESK CAN BE MATCHED WITH THE PALO BOOKSHELF,
INCREASING THE FEATURES OF THE PRODUCT.

DIELLE
GRUPPO DOIMO



UNO STILE DECORATIVO... AL FEMMINILE



MODULI IN LIBERTÀ

LA LIBRERIA PALO ALTO CONSENTE NUMEROSE CONFIGURAZIONI. TRA QUESTE SONO PARTICOLARMENTE INTERESSANTI LE INTEGRAZIONI CON COMPOSIZIONI A PONTE • THE PALO BOOKSHELF ALLOWS MANY MATCHES. AMONG THESE, THE INTEGRATIONS WITH BRIDGE COMPOSITIONS ARE PARTICULARLY INTERESTING.

LA PERFETTA INTEGRAZIONE

OTTENERE UNA PARETE CON TUTTE LE FUNZIONI È FACILE GRAZIE AL MIX APPEAL DEGLI ELEMENTI COSTITUTIVI • IT IS EASY OBTAINING A WALL WITH ALL THE FUNCTIONS, THANKS TO THE MIX APPEAL OF THE FUNDAMENTAL ELEMENTS.

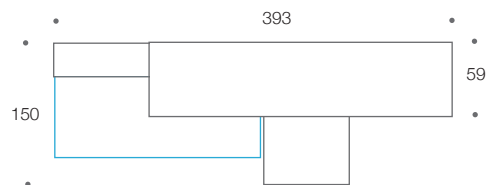

FINITURE - FINISHES (MELAMMINICI / LACCATI)
OLMO PERLA, OLMO NATURALE, ROSA, CORDA2.

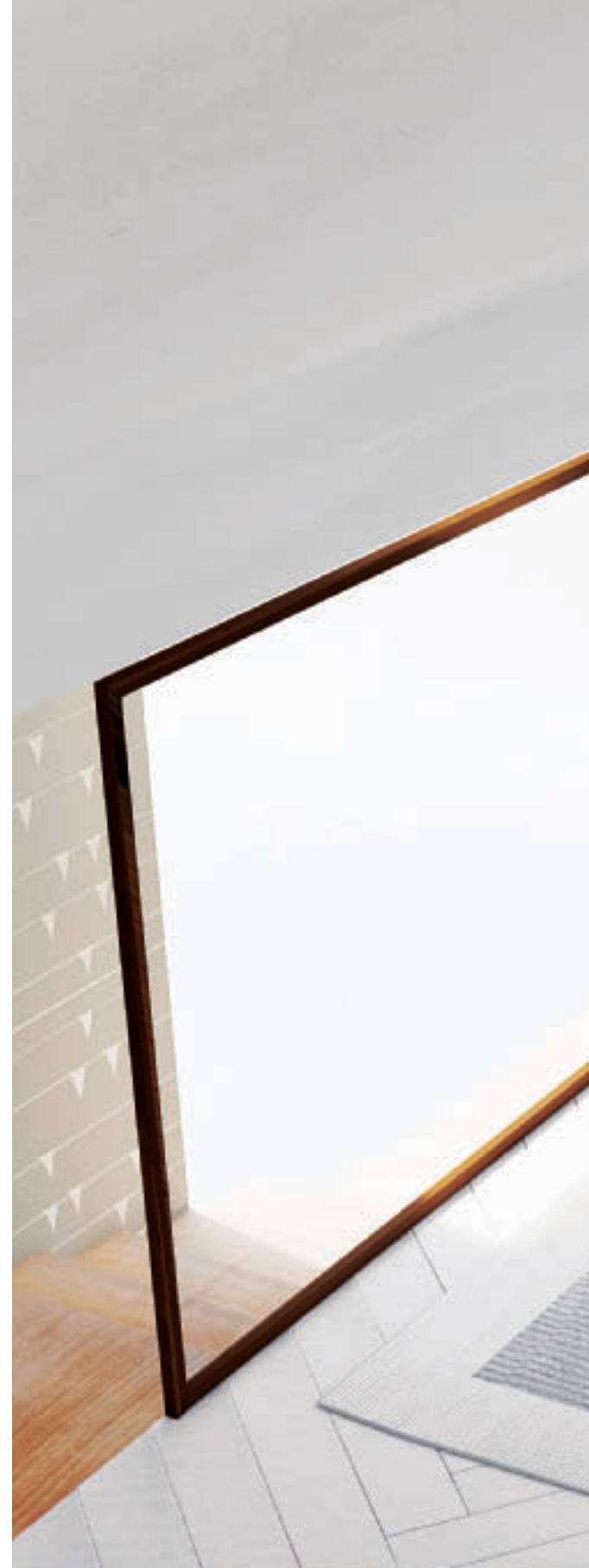



533



DOPPIO PONTE P06

LETTI INCROCIATI SOTTOPONTE

IL PONTE DI DIMENSIONI RILEVANTI PUÒ ACCOGLIERE DUE LETTI ATTREZZATI PERPENDICOLARI DAL DESIGN GIOVANE E FUNZIONALE • THE SIGNIFICANTLY SIZED BRIDGE CAN HOST TWO EQUIPPED UPRIGHT BEDS WITH THE FRESH AND FUNCTIONAL DESIGN.

LA SCRIVANIA INTEGRATA

UNA PRATICA SCRIVANIA INTEGRATA COMPLETA LA COMPOSIZIONE PER UNA PROGETTUALITÀ DI GRANDE EFFETTO • A PRACTICAL INTEGRATED DESK COMPLETES THE COMPOSITION FOR A GREAT DESIGN.

IL PONTE CONTENITIVO

LE SOLUZIONI PONTE MAXI PRESENTANO UNA NOTEVOLE CAPACITÀ CONTENITIVA UNITAMENTE A UNA GRANDE LIBERTÀ COMPOSITIVA • THE MAXI BRIDGE SOLUTIONS HAS A REMARKABLE CONTAINING CAPACITY, TOGETHER WITH A GREAT COMPOSING FREEDOM.

DOUBLE BRIDGE



UNIRE DUE PONTI ATTREZZATI



LA PARETE COMPATTA

UNENDO DUE STRUTTURE PONTE SI OTTIENE UNO SPAZIO SOTTOPONTE RADDOPPIATO CHE CONSENTE DI ALLESTIRE L'AMBIENTE IN PIENA LIBERTÀ • JOINING TWO BRIDGE STRUCTURES TOGETHER, A DOUBLE UNDER-BRIDGE SPACE CAN BE OBTAINED, WHICH ALLOWS TO FREE SET UP THE AREA.

LETTI DAL DESIGN ESCLUSIVO

I LETTI ATTREZZATI PRESENTANO UN DESIGN ESCLUSIVO, PENSATO PER INTEGRARSI CON GLI ALTRI ELEMENTI DI SISTEMA • THE EQUIPPED BEDS HAVE AN EXCLUSIVE DESIGN, WHICH IS SUPPOSED TO INTEGRATE ITSELF WITH THE OTHER SYSTEM ELEMENTS.

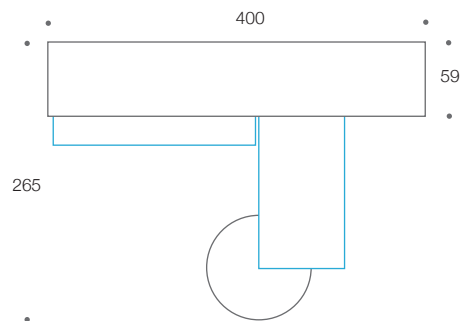

FINITURE - FINISHES (MELAMMINICI / LACCATI)
OLMO PERLA, GIRASOLE, CANAPA, ORIENTE.

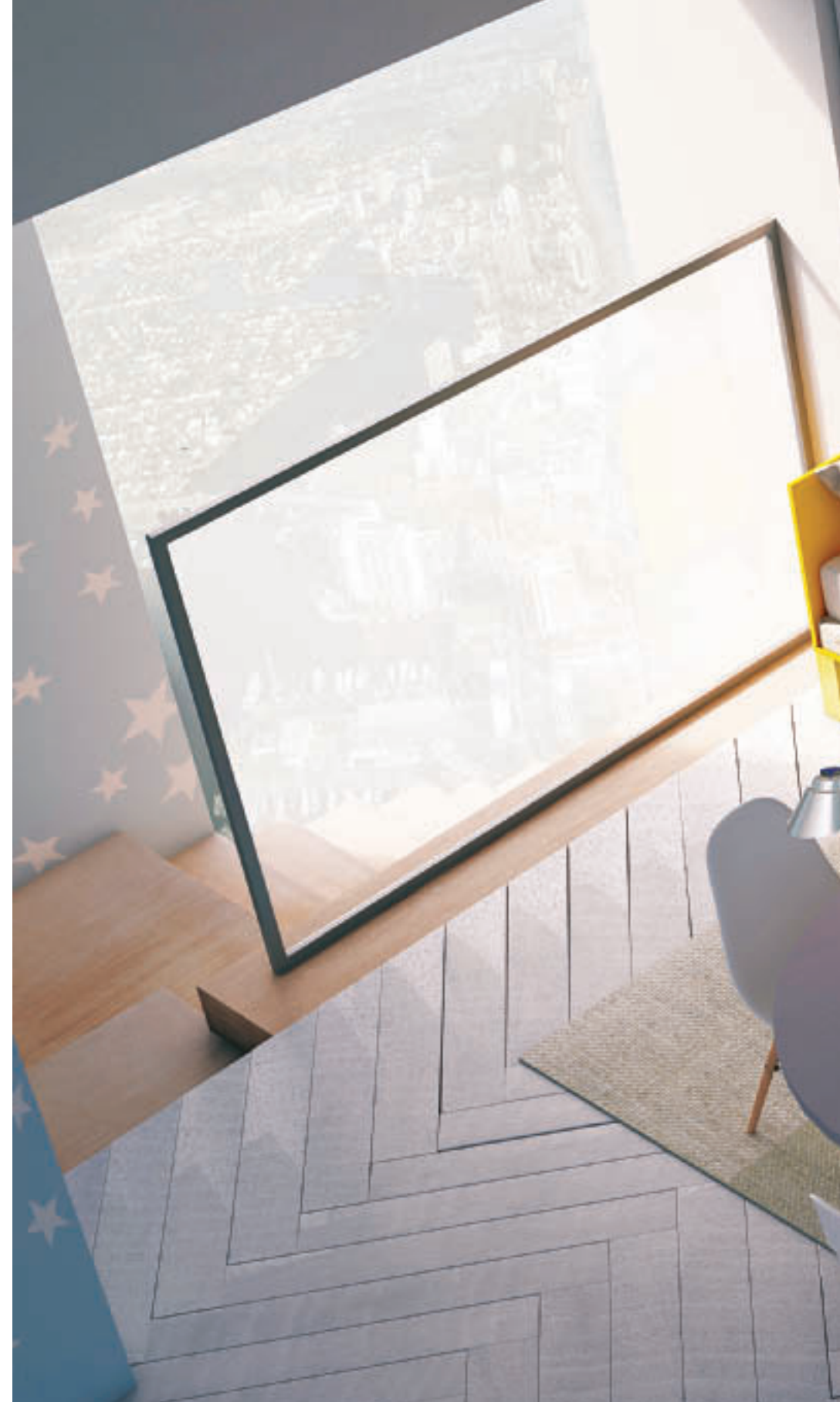



534

DISTINTIVI DETTAGLI DI STILE

LACCATI OPACO

LE LACCATURE OPACHE DI SISTEMA SONO STATE PERFEZIONATE PER UN PLANNING SENZA COMPROMESSI. COLORI TENUI O DECISI PER UN HABITAT PERSONALIZZATO • THE SYSTEM MATT LACQUERINGS HAVE BEEN IMPROVED FOR A NO COMPROMISE PLANNING. TENUOUS OR STRONG COLORS FOR A CUSTOMIZED HABITAT.

SPAZI SIMMETRICI

COMPORRE SPAZI SIMMETRICI DOVE LA PROPORZIONE E L'ARMONIA DEGLI ELEMENTI RENDE TUTTO PIÙ SEMPLICE E ESSENZIALE • COMPOSING SYMMETRIC SPACES WHERE THE PROPORTION AND THE ELEMENT'S HARMONY MAKE IT EASIER AND ESSENTIAL.

PER DUE RAGAZZI

SPESSO DUE RAGAZZI SI TROVANO A CONDIVIDERE LO STESSO SPAZIO. È ESSENZIALE DUNQUE TROVARE LE GIUSTE RISPOSTE PROGETTUALI • FREQUENTLY 2 BOYS HAVE TO SHARE THE SAME SPACE. IT IS ESSENTIAL TO FIND THE RIGHT PROJECT ANSWERS.

UNA SCRIVANIA PER DUE

ANCHE UNA SEMPLICE SCRIVANIA DA CONDIVIDERE PUÒ ESSERE UNA SOLUZIONE INTERESSANTE • ALSO A SIMPLE DESK TO BE SHARED CAN BE AN INTERESTING SOLUTION.

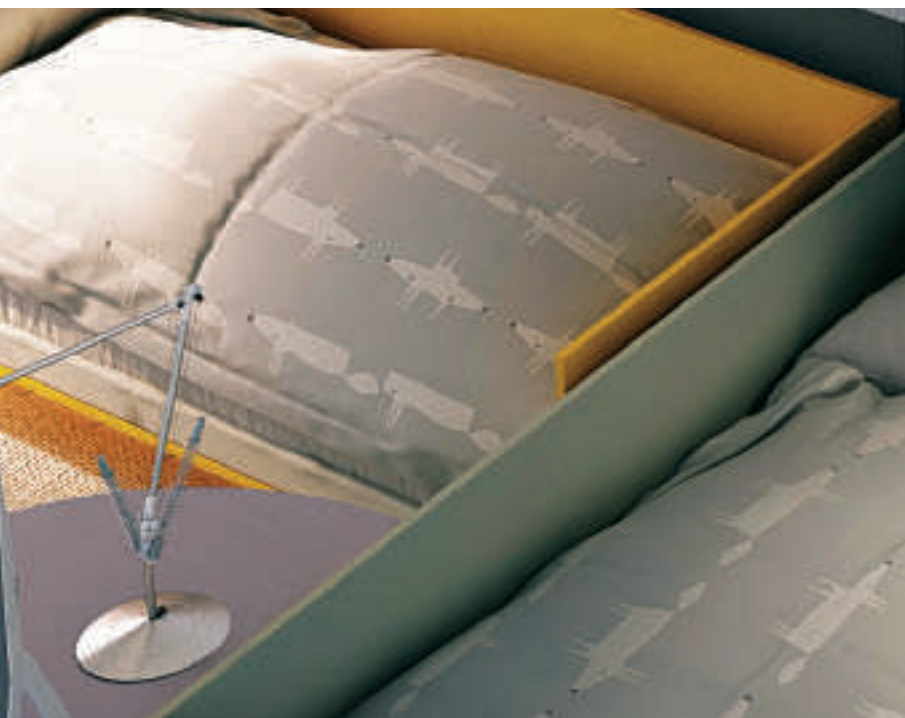

LETTO TESSILE E LEGNO

DIELLE PRODUCE UN'AMPIA COLLEZIONE DI LETTI TESSILI E LEGNO, ATTREZZATI DI TUTTO PUNTO, PERSONALIZZABILI A PIACERE •
DIELLE PRODUCES A WIDE RANGE OF TEXTILE AND WOODEN BEDS, COMPLETELY EQUIPPED, TASTEFULLY CUSTOMIZABLE.

ANTE SCORREVOLI

GLI ELEMENTI PONTE POSSONO ESSERE DOTATI DI ANTE SCORREVOLI CHE NON PRESENTANO INGOMBRO IN APERTURA • THE BRIDGE ELEMENTS CAN BE EQUIPPED WITH SLIDING DOORS, THEY DON'T HAVE ANY FOOTPRINT WITH THE OPENING.

DIELLE
GRUPPO DOIMO

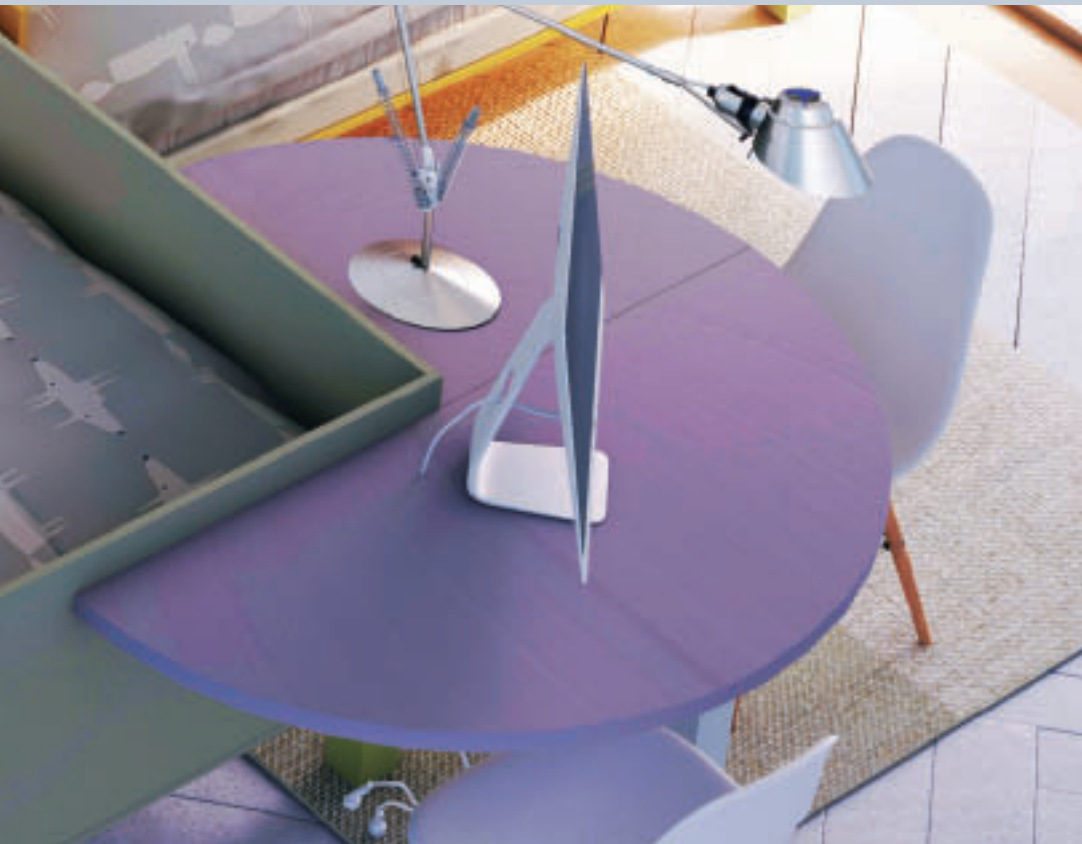

535



PONTE DOPPIO SCORREVOLE



DOUBLE SLIDING DOORS BRIDGE CUPBOARD

LA TEXTURE COME SFONDO

L'ELEGANTE TEXTURE CARBONCINO DIVENTA UNO SFONDO IDEALE SOTTOPONTE CHE PERSONALIZZA L'AMBIENTE • THE ELEGANT "CARBONCINO" TEXTURE BECOMES AN IDEAL BACKGROUND UNDER THE BRIDGE CUPBOARD CUSTOMIZING THE ROOM.

NUANCES RICERCATE

IL SISTEMA CROMATICO DIELE PROPONE COLORI MODA RICERCATI E ATTUALI NEL SEGNO DI UNA PERSONALITÀ DISTINTIVA • THE DIELE CHROMATIC SYSTEM OFFERS REFINED AND RECENT FASHION COLOURS IN THE SIGN OF A DISTINCTIVE PERSONALITY.

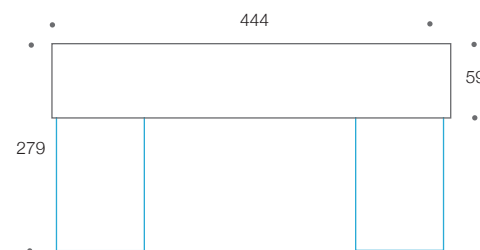

FINITURE - FINISHES (MELAMMINICI / LACCATI)
 OLMO CENERE, BIANCO, PRUSSIA, CORDA2, MUSCHIO.



PONTE & CABINE ANGOLARI

P07

BRIDGE & CORNER CABS

CABINE ANGOLARI

LA COMPONIBILITÀ ANGOLARE È UNO DEI PLUS PRINCIPALI DELLA MODULARITÀ DI SISTEMA CHE IL PROGRAMMA INTERPRETA IN TUTTE LE SUE DECLINAZIONI • THE CORNER MODULARITY IS ONE OF THE MAIN "PLUS" OF THE SYSTEM COMPOSABILITY INTERPRETED BY THE PROGRAM IN ALL THE POSSIBLE SOLUTIONS.

IL RACCORDO IDEALE

LE CABINE ARMADIO ANGOLARI SONO PROPOSTE CON UNA O DUE ANTE E HANNO LE PROFONDITÀ IDEALI PER OGNI PROGETTO • THE CORNER CUPBOARD CABS ARE PROPOSED WITH ONE OR TWO DOORS, THEY HAVE THE PERFECT DIMENSIONS FOR EVERY PROJECT.

LA PERSONALITÀ DEL LETTO

IL LETTO CARATTERIZZA IL LOOK DELL'AMBIENTE, È IL CENTRO DEL PROGETTO E ANCHE LA ZONA PIÙ VISSUTA DELLA CAMERETTA • THE BED CHARACTERIZES THE ROOM'S LOOK, IT'S THE CENTER OF THE PROJECT AND ALSO THE MOST USED AREA OF THE BEDROOM.



L'ARMADIATURA CON TUTTE LE FUNZIONI



UN ARMADIO... SENZA FINE

A FIANCO DELLA CABINA ANGOLARE: DA UN LATO IL PONTE ACCOGLIE UNA ZONA RIPOSO, DALL'ALTRO UN GRANDE ARMADIO CON SCRITTOIO ESTRAIBILE • BESIDE THE CORNER CAB: ON ONE SIDE THE BRIDGE INCLUDES A RESTING AREA, ON THE OTHER SIDE A BIG WARDROBE WITH AN EXTRACTABLE WRITING DESK.

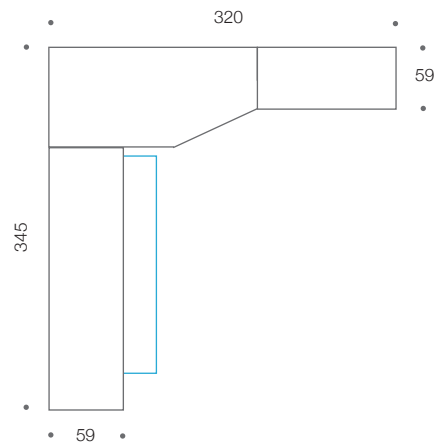

FINITURE - FINISHES (MELAMMINICI / LACCATI)
OLMO PERLA, OLMO NATURALE, PETROLIO2, TEXTURE ARLECCHINO.





536



CONTINUITY IN THE CORNER CABIN

LA CABINA ANGOLARE CONSENTE DI PROGETTARE SENZA SOLUZIONE DI CONTINUITÀ LO SPAZIO RAGAZZI. COSÌ, SI POSSONO AGGREGARE ZONE STUDIO AD ELEMENTI PENSILI, AREA RIPOSO CON LETTI ATTREZZATI E TERMINALI A LIBRERIA PER UN PLANNING LIBERO E PERSONALIZZATO • THE CORNER CABIN ALLOWS TO PLAN THE KIDS AREA WITHOUT CONTINUITY SOLUTIONS. IN THIS WAY WE CAN UNITE STUDYING AREAS AND PENSILE ELEMENTS, THE RESTING AREA WITH EQUIPPED AND BOOKSHELF ENDED FOR A FREE AND CUSTOMIZED PLANNING.

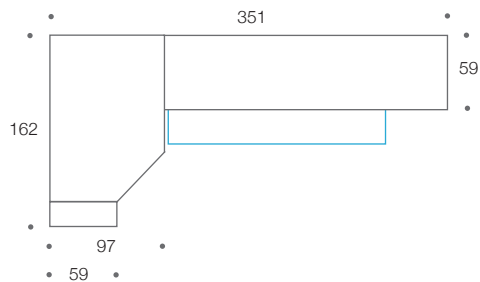

FINITURE - FINISHES (MELAMMINICI / LACCATI)
OLMO PERLA, OLMO NATURALE, NUVOLA, CORDA2.





537

MODULO ANGOLARE A UN'ANTA E LIBRERIA



LA CABINA A UN'ANTA - GIULIA

GIULIA È LA SOLUZIONE CABINA ARMADIO ANGOLARE DOTATA DI UNA SOLA ANTA. È LA SOLUZIONE IDEALE PER COMPOSIZIONI COMPATTE • GIULIA IS THE CORNER CABIN SOLUTION WITH JUST ONE DOOR. IT IS THE IDEAL SOLUTION FOR COMPACT COMPOSITIONS.

LIBRERIA TERMINALE

LA MODULARITÀ DI SISTEMA CONSENTE LA FORMAZIONE DI COMPOSIZIONI ARTICOLATE DOTATE DI LIBRERIE TERMINALI • THE SYSTEM MODULARITY ALLOWS THE FORMATION OF COMPLEX COMPOSITIONS WITH TERMINAL BOOKSHELVES.

MODULO ANGOLARE A DUE ANTE

CORNER MODULE WITH TWO DOORS



LA CABINA A DUE ANTE - EMILY / SARA

EMILY E SARA SONO LE CABINE ANGOLARI A DUE ANTE. QUESTE SOLUZIONI SONO PARTICOLARMENTE INDICATE PER UN'ELEVATA CAPACITÀ CONTENITIVA • EMILY AND SARA ARE THE TWO DOOR CORNER CABINS, THESE SOLUTIONS ARE PARTICULARLY INDICATED FOR AN ELEVATE CONTAINING CAPACITY.

ELEVATO CONTENIMENTO

GRAZIE ALLE SUE GENEROSE DIMENSIONI, LA CABINA ANGOLARE CREA SPAZIO PER OGNI DESTINAZIONE D'USO. DAGLI ABITI AL CORREDO TESSILE, AGLI OGGETTI INGOMBRANTI • THANKS TO ITS GENEROUS DIMENSIONS, THE CORNER CABIN CREATES SPACE FOR EVERY USE, FROM CLOTHES TO SHEETS, TO BIG OBJECTS.

DIELLE
GRUPPO DOIMO



538



SVILUPPO SU DUE PARETI

PROGRESSION ON TWO WALLS



SVILUPPARE IL PROGETTO SPAZIO RAGAZZI SU DUE PARETI CON TUTTE LE FUNZIONI ESSENZIALI: RIPOSO, GIOCO, STUDIO E CONTENERE È POSSIBILE... IN QUESTO CASO LA CABINA ANGOLARE RACCORDA, PERFETTAMENTE, LA ZONA STUDIO CON L'AREA RIPOSO • IT IS POSSIBLE TO DEVELOP THE KIDS AREA PROJECT ON TWO WALLS WITH ALL THE ESSENTIAL FUNCTIONS: RESTING, PLAYING, STUDYING AND CONTAINING... IN THIS CASE THE CORNER CABIN LINKS PERFECTLY THE STUDYING AREA WITH THE RESTING AREA.

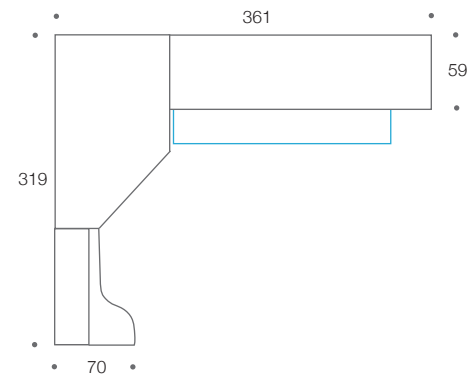

FINITURE - FINISHES (MELAMMINICI / LACCATI)
OLMO PERLA, ORIENTE, TEXTURE PUNTO.



539



INTEGRARE IL PONTE ALL'AREA STUDIO

INTEGRATING THE BRIDGE WITH THE STUDYING AREA



UN ALTRO ESEMPIO DI PERFETTA INTEGRAZIONE TRA GLI ELEMENTI COSTITUTIVI DI SISTEMA È RAPPRESENTATA IN QUESTA VERSATILE SOLUZIONE PROGETTUALE: LETTO, SCRIVANIA E ACCESSORI ACCOSTATI ALLA CABINA ANGOLARE • ANOTHER EXAMPLE OF A PERFECT INTEGRATION BETWEEN THE SYSTEM CONSTITUTIVE ELEMENTS IS REPRESENTED BY THIS VERSATILE PROJECT SOLUTION: BED, DESK AND ACCESSORIES MATCHED TO THE CORNER CAB.

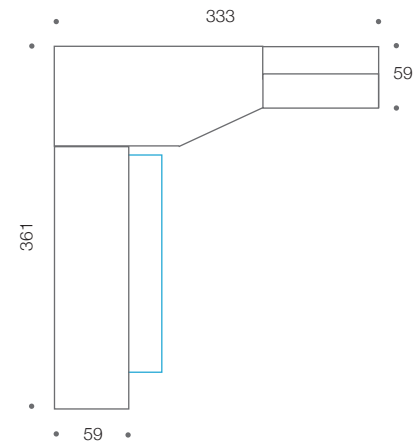

FINITURE - FINISHES (MELAMMINICI / LACCATI)
 OLMO NATURALE, OLMO PERLA, GRIGIO SCURO, MUSCHIO.
 TEXTURE RIGA.



PONTE ANGOLARE CON COLONNA CONTENITORE

P08

L'APPOGGIO RETROLETTO

LA COLONNA SOTTOPONTE È IL COMPLEMENTO IDEALE CHE AUMENTA LA FUNZIONALITÀ DELL'AREA RIPOSO • THE UNDER-BRIDGE COLUMN IS THE IDEAL DETAIL INCREASING THE FUNCTIONALITY OF THE RESTING AREA.

IL CONTENITORE PER I CUSCINI E IL PIUMONE

UN PRATICO CONTENITORE DOVE CUSTODIRE IL CUSCINO O IL CORREDO TESSILE PERFETTAMENTE INTEGRATO RETRO LETTO • A PRACTICAL CONTAINER IN WHICH YOU CAN SAFEGUARD YOUR PILLOW OR THE TEXTILE SET PERFECTLY INTEGRATED BEHIND THE BED.

L'ANGOLO SUPERIORE SFRUTTABILE

ANCHE LA PARTE SUPERIORE DELL'ELEMENTO SOTTOPONTE RAPPRESENTA UNO SPAZIO FRUIBILE E DI SERVIZIO • ALSO THE UPPER SIDE OF THE UNDER-BRIDGE ELEMENT CAN BE A USABLE SERVICE SPACE.

CORNER BRIDGE WITH CONTAINING COLUMN



540





LIBRERIA A PALO BIFACCIALE

PONTE ANGOLARE CON COLONNA | CORNER BRIDGE WITH COLUMN

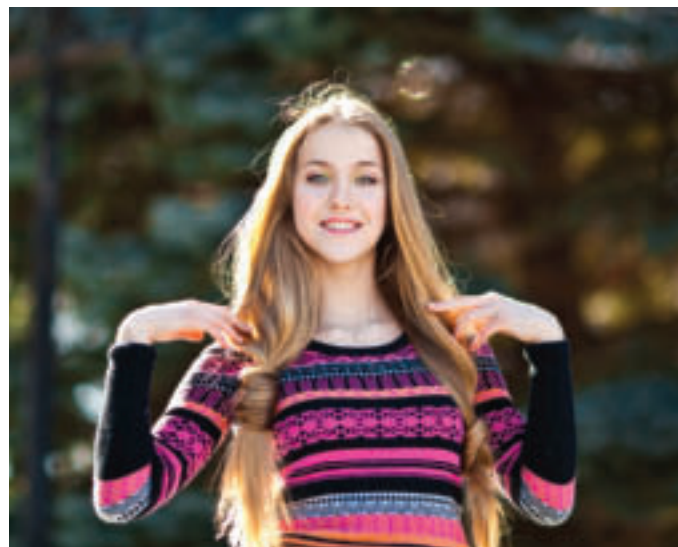

DOUBLE SIDE PALO BOOKSHELF

LA LIBRERIA PALO ALTO È UN SISTEMA COMPONIBILE CON LE DIMENSIONI IDEALI PER OGNI AMBIENTE SIA IN LARGHEZZA CHE IN ALTEZZA. PUÒ ESSERE LIBERAMENTE AGGREGATO AI PONTI, ALLE SCRIVANIE E AI LETTI PER CONFIGURARE AMBIENTI FUNZIONALI E RAPPRESENTATIVI • THE BOOKSHELF PALO IS A MODULAR SYSTEM WITH THE IDEAL DIMENSIONS FOR EVERY SPACE BOTH WIDTH AND HEIGHT. THEY CAN BE CONNECTED TO BRIDGES, DESKS AND TO BEDS AS WELL TO CONFIGURE FUNCIONAL AND REPRESENTATIVE ROOMS.

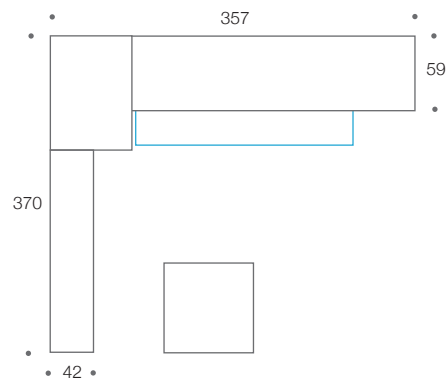

FINITURE - FINISHES (MELAMMINICI / LACCATI)
 OLMO PERLA, ZUCCA, CORDA2, CANAPA, CRETA,
 TEXTURE ARLECCHINO.

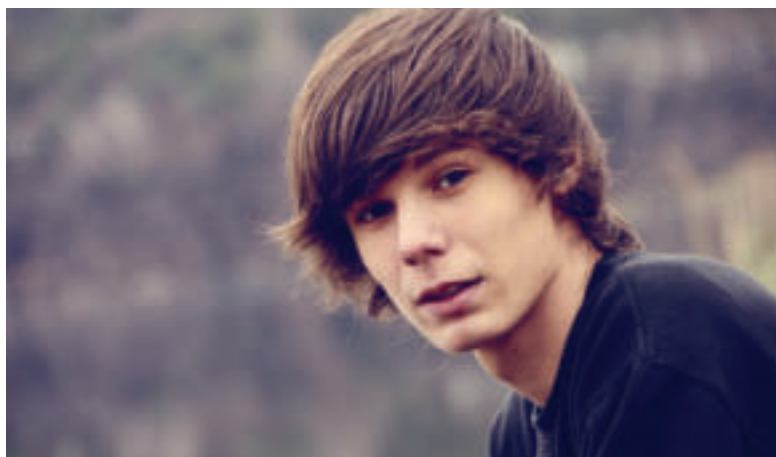

CORNER ELEMENTS IN CORNER MODULARITY

LA COMPONENTI ANGOLARE È UNO DEI TEMI PIÙ INTERESSANTI DELLA TEMATICA "SPAZIO RAGAZZI" SIA PER LA SUA PRATICITÀ D'USO, SIA PER LA CONTINUITÀ PROGETTUALE CHE GARANTISCE. L'ALTO GRADO DI SPECIALIZZAZIONE DI SISTEMA PROPONE ELEMENTI PERFETTAMENTE INTEGRATI • THE CORNER MODULARITY IS ONE OF THE MOST INTERESTING THEMES TALKING ABOUT "CHILDREN SPACE" BOTH FOR ITS PRACTICALITY AND FOR ITS PROJECT CONTINUITY. THE HIGH LEVEL OF SYSTEM SPECIALISATION PROPOSES ELEMENTS PERFECTLY INTEGRATED.

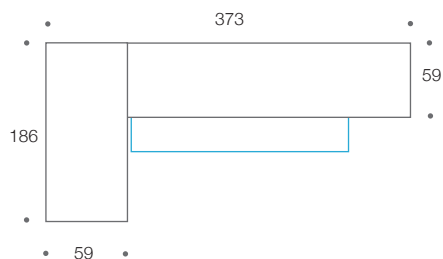

FINITURE - FINISHES (MELAMMINICI / LACCATI)
 OLMO PERLA, OLMO NATURALE, CRETA, CORDA2, MOKA.





541

542





UN ARREDO PER DUE RAGAZZI

PONTE ANGOLARE CON COLONNA | CORNER BRIDGE WITH COLUMN



A FURNISHING FOR TWO KIDS

LA PROGETTAZIONE IDEALE DI SOLUZIONI PER DUE RAGAZZI SI PUÒ AFFRONTARE CONSIDERANDO LA COMPONIBILITÀ ANGOLARE COME ELEMENTO PRIMARIO. DUE LETTI ARKIMEDE ATTREZZATI SONO IL FULCRO DEL PROGETTO... IL VANO PORTA TV/MONITOR È ADIACENTE ALLA SCRIVANIA GHOST A SCOMPARSA • THE IDEAL DESIGN OF SOLUTIONS FOR TWO KIDS CAN BE FACED CONSIDERING THE CORNER MODULARITY AS A MAIN ELEMENT. TWO EQUIPPED ARKIMEDE BEDS ARE THE PROJECT HEART ... THE SPACE FOR TV/COMPUTER IS NEXT TO THE GHOST HIDING DESK.

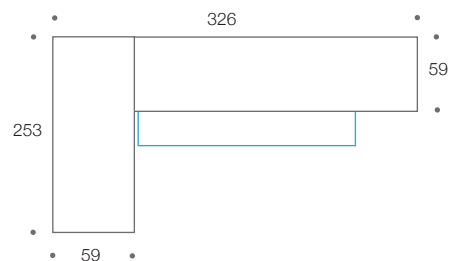

FINITURE - FINISHES (MELAMMINICI / LACCATI)
OLMO PERLA, POLVERE, CORDA2, MAGNOLIA, GIRASOLE.



THE DIVIDING STUDY AREA

LA LIBRERIA PALO ALTO CONSENTE LA REALIZZAZIONE DI COMPOSIZIONI VARIABILI IN ALTEZZA E LARGHEZZA. INOLTRE PROPONE SOLUZIONI INTERPARETE FRUIBILI DA ENTRAMBI I LATI. UNA DIVISIONALITÀ CHE CREA SPAZI ORGANIZZATI E PIENAMENTE FUNZIONALI • THE PALO ALTO BOOKSHELF ENABLES SEVERAL COMPOSITIONS VARIABLE IN HEIGHT AND WIDTH. ALSO PROPOSES DIVIDING SOLUTIONS USABLE ON BOTH SIDES. A DIVISIONAL SYSTEM CREATING ORGANIZED SPACES FULL OF FUNCTIONALITY.

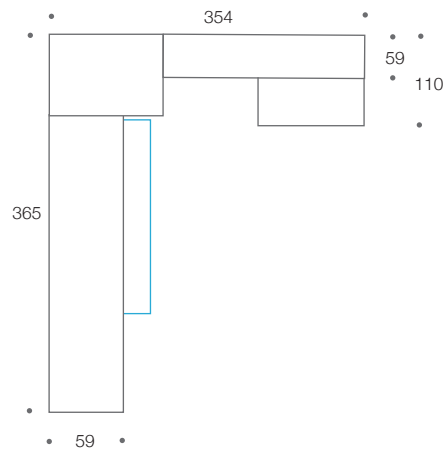

FINITURE - FINISHES (MELAMMINICI / LACCATI)
 OLMO CENERE, BIANCO, CANARINO, ROSA, NUVOLA, PETROLIO2,
 VERDE PRIMAVERA.

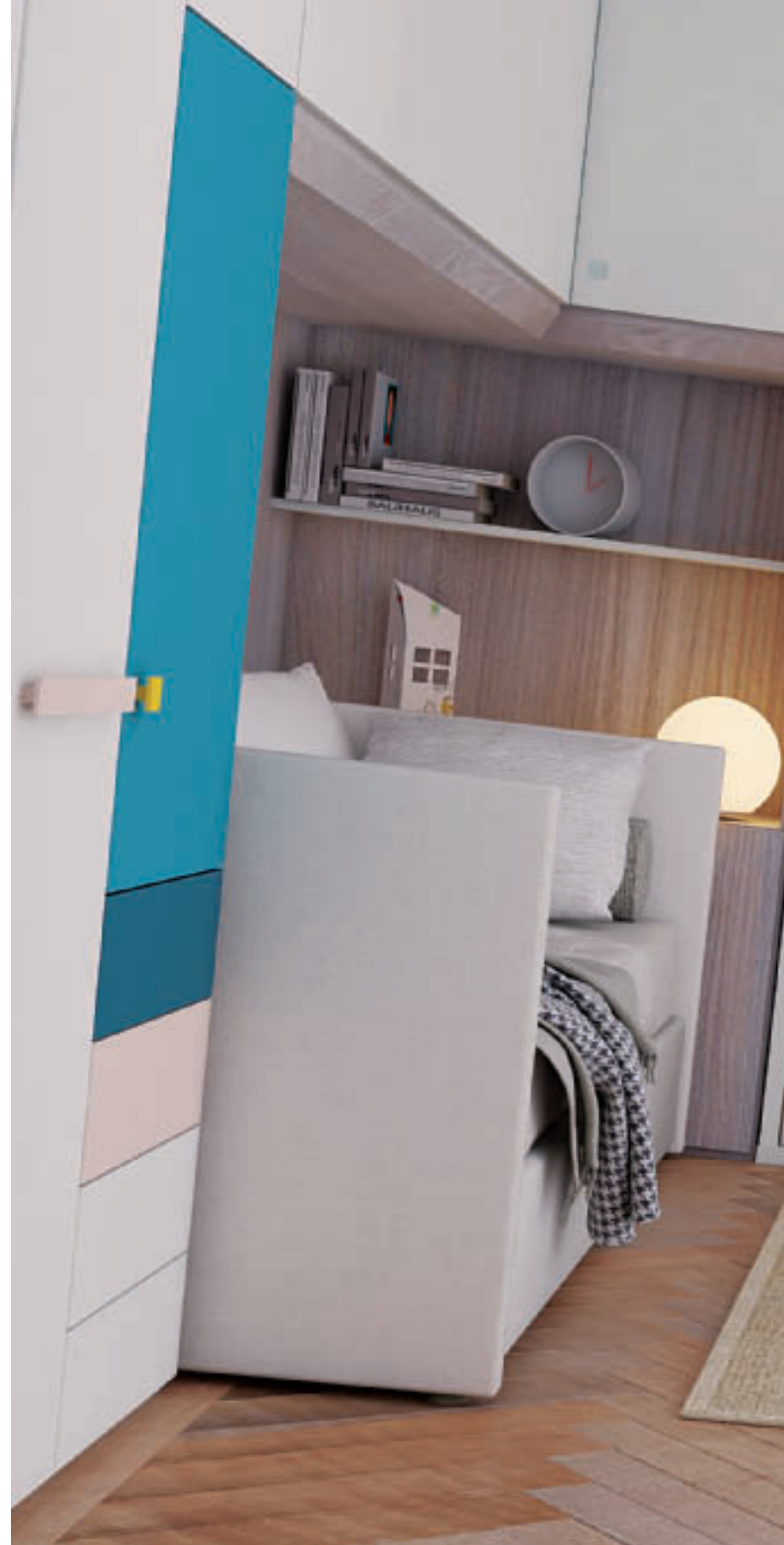



543



PONTE ANGOLARE COMPATTO

P09

IL LETTO LONGITUDINALE

UNA SOLUZIONE PONTE PROPOSTA CON LETTO LONGITUDINALE E COMODINO DI SERVIZIO • A BRIDGE SOLUTION PROPOSED WITH LONGITUDINAL BED AND SERVICE BED SIDE.

IL GIOCO DELLE ESSENZE

IL NOBILITATO OLMO CREA UNO SPAZIO INTIMISTA SOTTOPONTE. UN'IDEA DI NATURALITÀ DELL'ARREDO • THE ELM MELAMINE CREATES AN INTIMATE SPACE BELOW THE BRIDGE. IT IS A NATURALNESS IDEA FOR THE FURNISHING.

IL TERMINALE A PALO

IL TERMINALE PALO ALTO È PERSONALIZZABILE A PIACERE CON LE LACCATURE OPACHE DI SISTEMA • THE ENDING "PALOALTO" BOOKSHELF IS TASTEFULLY CUSTOMIZABLE WITH SYSTEM MATT FINISHES.

COMPACT CORNER BRIDGE

DIELLE
GRUPPO DOIMO





ENDING OPEN ELEMENT

PALO ALTO PROPONE UNA COLLEZIONE DI ELEMENTI A GIORNO E CONTENERE componibili in tante declinazioni. ANCHE LE SOLUZIONI MINIMALI COME I TERMINALI A GIORNO RAPPRESENTANO UN VALIDO SUPPORTO PROGETTUALE NELLA DEFINIZIONE DEGLI AMBIENTI • PALO ALTO PROPOSES A COLLECTION OF OPEN AND CONTAINING ELEMENTS COMPOSABLE IN SEVERAL COMBINATIONS. ALSO THE MINIMAL SOLUTIONS LIKE THE ENDING OPEN UNITS REPRESENTING A VALID PROJECT SUPPORT IN THE ROOM'S DEFINITION.

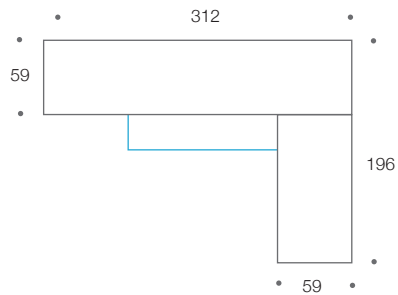

FINITURE - FINISHES (MELAMMINICI / LACCATI)
OLMO NATURALE, BIANCO, MANDARINO, CRETA.





544



THE UNDER-BRIDGE INTEGRATED DESK

UNA SOLUZIONE VENTIQUEATTRORE DOVE L'INTEGRAZIONE DEGLI ELEMENTI COSTITUISCE IL VERO PLUS DEL PRODOTTO. LA GRANDE SCRIVANIA SOTTOPONTE È ARMONIOSAMENTE ACCOSTATA AL LETTO DESIGN E AL TERMINALE LIBRERIA PALO ALTO • A TWENTY-FOUR HOURS SOLUTION IN WHICH THE INTEGRATION OF THE ELEMENTS IS THE REAL "PLUS" OF THE PRODUCT. THE BIG DESK PLACED BELOW THE BRIDGE CUPBOARD IS HARMONIOUSLY COMBINED TO THE DESIGN BED AND TO THE ENDING BOOKSHELF PALOALTO.

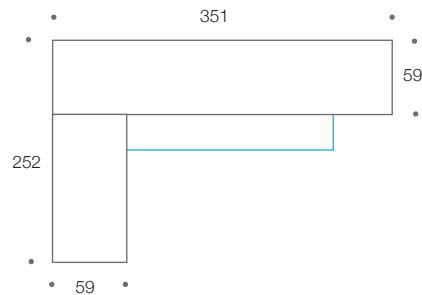

FINITURE - FINISHES (MELAMMINICI / LACCATI)
OLMO PERLA, CANAPA, ZUCCA.

LA SCRIVANIA INTEGRATA SOTTOPONTE





545



IL TERMINALE A GIORNO / LIBRERIA PALO ALTO

UNA SOLUZIONE A PONTE ANGOLARE DECLINATA AL FEMMINILE CON COLORI TENUI. IL SISTEMA CROMATICO DIELE CONSENTE INTERPRETAZIONI DIVERSIFICATE NEL SEGNO DI UNA PERSONALITÀ DISTINTIVA • A CORNER BRIDGE SOLUTION DECLINED TO THE WOMAN'S LIFE WITH SOFT COLOURS, THE DIELE CHROMATIC SYSTEM ALLOWS TO DIVERSIFY INTERPRETATIONS IN THE SIGN OF A DISTINCTIVE PERSONALITY .

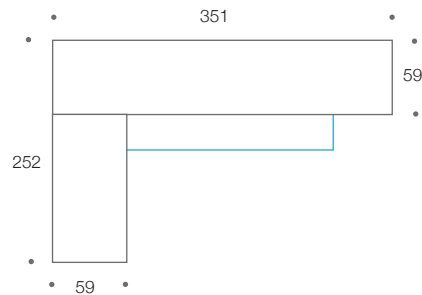

FINITURE - FINISHES (MELAMMINICI / LACCATI)
BIANCO, CRETA, ROSA.

THE OPEN ENDING ELEMENT / BOOKSHELF PALO ALTO





546



NELL'ANGOLO... DUE O TRE LETTI ESTRAIBILI

CON IL SISTEMA DI LETTI SOVRAPPONIBILI ARKIMEDE, IN SOLI DUE METRI QUADRATI SI POSSONO ACCORPARE FINO A TRE LETTI, RECUPERANDO COSÌ FINO A QUATTRO METRI QUADRATI DI SPAZIO DA DEDICARE AL GIOCO ED ALTRE FUNZIONI. IL SISTEMA LETTI ARKIMEDE PRESENTA ANCHE CASSETTONI E ADDIRITTURA SCRITTOIO ESTRAIBIBILE • WITH THE SYSTEM OF THE ARKIMEDE OVERLAPPING BEDS, IN ONLY TWO SQUARE METERS YOU CAN MERGE UP TO THREE BEDS, RECOVERING UP TO FOUR SQUARE METERS OF FREE SPACE TO BE DEDICATED TO THE GAME AND TO OTHER FUNCTIONS. THE ARKIMEDE BEDS SYSTEM HAVE ALSO BIG DRAWERS AND EVEN AN EXTRACTIBLE DESK.

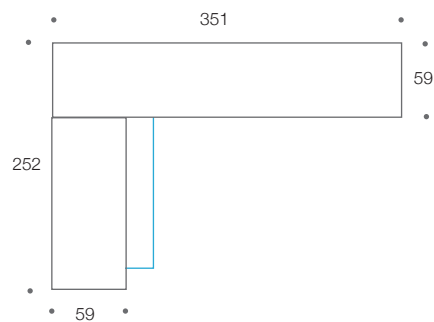

FINITURE - FINISHES (MELAMMINICI / LACCATI)
OLMO NATURALE, OLMO PERLA, CRETA.

IN THE CORNER... TWO OR THREE EXTRACTIBLE BEDS

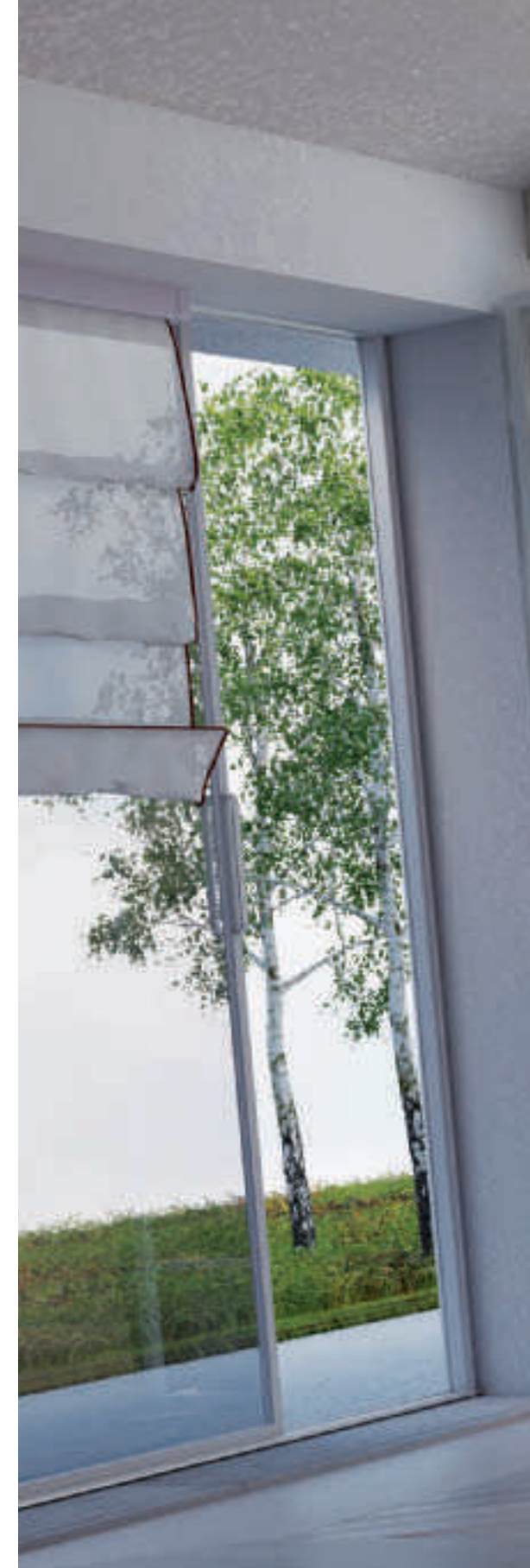



547



TWIN TEXTILE BEDS

UNA STRUTTURA A PONTE ANGOLARE ACCOGLIE DUE LETTI TESSILI GEMELLARI PER DUE RAGAZZI. IL TERMINALE A GIORNO PALO ALTO COMPLETA LA COMPOSIZIONE. LE FINITURE IN NOBILITATO OLMO DIALOGANO CON LE LACCATURE E LE COLORATE TRAME TESSILI • THE CORNER BRIDGE STRUCTURE RECEIVES A COUPLE OF TEXTILE BEDS FOR TWO BOYS. THE OPEN ENDING "PALO ALTO" BOOKSHELF COMPLETES THE COMPOSITION. THE ELM MELAMINE FINISHES INTERACT WITH THE LACQUERING AND THE COLOURED TEXTILE TEXTURES.

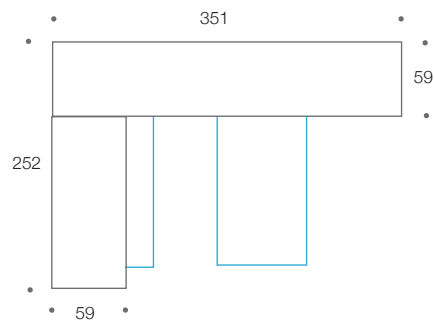

FINITURE - FINISHES (MELAMMINICI / LACCATI)
OLMO PERLA, CANAPA, CORDAZ.

LETTI TESSILI GEMELLARI





548



PONTE AD ANGOLO CON COLONNA MASTER

P10

MIX APPEAL

È DALLA COERENTE FUSIONE TRA TESSUTI, FINITURE DI SISTEMA E LACCATURE OPACHE CHE NASCE UN PROGETTO DI INTERIOR DESIGN AVANZATO • BY THE LOGICAL FUSION AMONG FABRICS, SYSTEM FINISHES AND MATT LACQUERING THAT AN ADVANCED PROJECT OF INTERIOR DESIGN WAS BORN.

PERFETTA INTEGRAZIONE TRA SISTEMI

TUTTI I MASSIMI SISTEMI DIELE SONO PERFETTAMENTE INTEGRATI PER ASPETTO ESTETICO E FINITURE • ALL THE GREATEST DIELE SYSTEMS ARE PERFECTLY INTEGRATED FOR AESTHETIC ASPECT AND FINISHES.

TUTTE LE FUNZIONI

LA POLIFUNZIONALITÀ DEL PROGRAMMA PREVEDE L'ESPLORAZIONE DI TUTTE LE ZONE FUNZIONALI DELLO STUDIO-GIOCO, DELL'AREA RELAX E DEL CONTENERE • THE MULTIFUNCTIONALITY OF THE PROGRAM INCLUDES ALSO THE EXPLORATION OF ALL THE STUDYING - PLAYING FUNCTIONAL AREAS, OF THE RELAXING ZONE AND OF THE CONTAINMENT.

CORNER BRIDGE WITH MASTER TALL UNIT





DESIGNING THE INTEGRATED STUDY AREA

PROGETTARE UNA ZONA STUDIO DI GRANDE FUNZIONALITÀ CON GLI ELEMENTI DEL SISTEMA MASTER È UN PLUS MOLTO IMPORTANTE PER LA GRANDE DUTTILITÀ DEGLI ELEMENTI. MASTER È IL SISTEMA A FIANCO PORTANTE CHE ALTERNA SPAZI A GIORNO AD ELEMENTI CON ANTE CON LE MISURE GIUSTE PER OGNI PROGETTO • DESIGNING A STUDY ZONE OF GREAT FUNCTIONALITY WITH THE MASTER SYSTEM ELEMENTS IS A VERY IMPORTANT "PLUS" FOR THE ELEMENTS FLEXIBILITY. MASTER IS A BOOKSHELF SYSTEM THAT INCLUDES OPEN SPACES AND ELEMENTS WITH DOORS, DRAWERS AND BASKETS AND THE DIMENSIONS ARE PERFECT IN EVERY PROJECT.

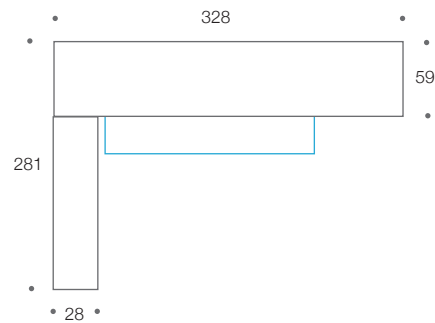

FINITURE - FINISHES (MELAMMINICI / LACCATI)
 OLMO PERLA, OLMO NATURALE, CANAPA, CORDA2, MAGNOLIA,
 ALABASTRO, TURCHESE, TEXTURE RIGA.

PROGETTARE LA ZONA STUDIO INTERGRATA





549



DESIGNING WITH THE MASTER TALL UNIT

LA COLONNA MASTER SOTTOPONTE COSTITUISCE IL RACCORDO PERFETTO TRA LA SOLUZIONE A PONTE E LA ZONA STUDIO-GIOCO INTEGRATA. UN INTERO PROGRAMMA A FIANCO PORTANTE E A COMPLETA DISPOSIZIONE DEL PROGETTISTA • THE MASTER TALL UNIT PLACED BELOW THE BRIDGE IS THE PERFECT CONNECTION BETWEEN THE BRIDGE WARDROBE AND THE INTEGRATED STUDY-GAME AREA. A COMPLETE SET OF BOOKSHELF MODULES AT COMPLETE DISPOSAL OF THE DESIGNER.

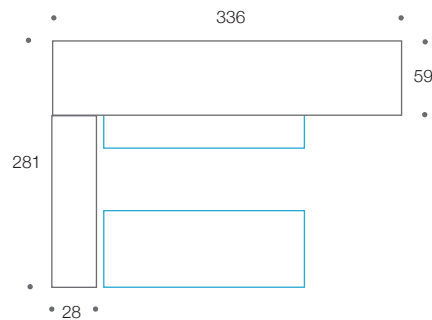

FINITURE - FINISHES (MELAMMINICI / LACCATI)
 OLMO NATURALE, BIANCO, GRIGIO CHIARO, POLVERE, ORIENTE.

PROGETTARE CON LA COLONNA MASTER

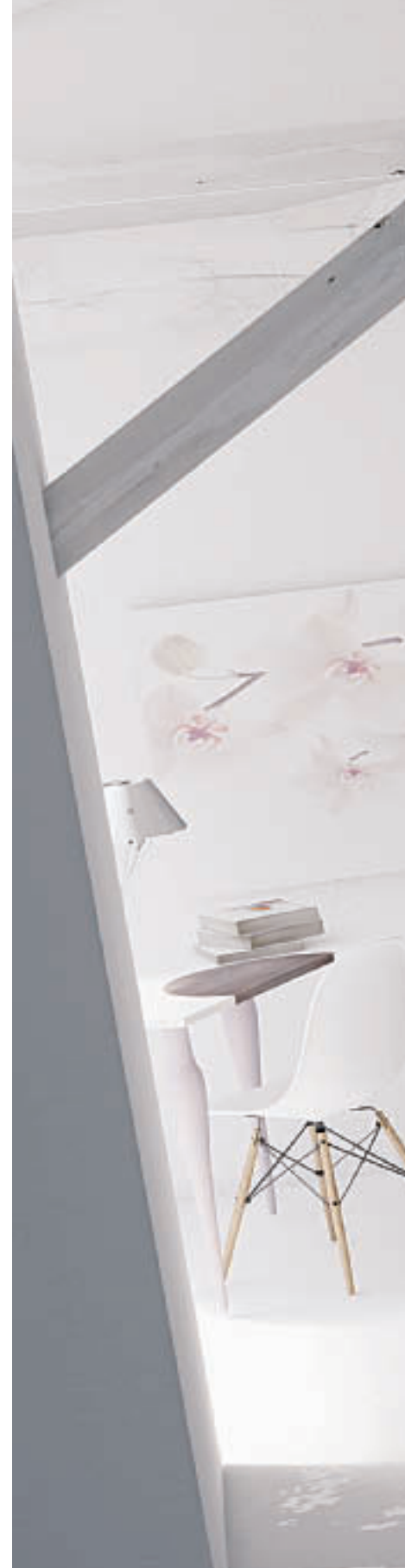



550



THE BOOKCASE IN DIFFERENTIATE HEIGHTS

LA LIBRERIA MASTER A FIANCO PORTANTE HA LE MISURE GIUSTE PER OGNI ALTEZZA. MASTER CONSENTE ORIGINALI COMPOSIZIONI INTERPARETE • THE MASTER BOOKCASE WITH LOAD-BEARING STRUCTURE HAS PERFECT DIMENSIONS FOR ALL THE HEIGHTS. MASTER ALLOWS ORIGINAL DOUBLE-SIDED COMPOSITIONS.

FINITURE - FINISHES (MELAMMINICI / LACCATI)
BIANCO, GRIGIO CHIARO.

LA LIBRERIA AD ALTEZZE DIFFERENZIATE





551



PONTE CON ALTEZZA MAXI

P11

ANTA MAXI

LE COMPOSIZIONI A PONTE CON ANTA MAXI PRIVILEGIANO IL CONTENIMENTO RISPETTO AD ALTRE FUNZIONI • THE BRIDGE COMPOSITIONS WITH MAXI DOOR PRIVILEGE THE CONTAINMENT THAN OTHER FUNCTIONS.

GRANDE SOLUZIONE PER PICCOLI SPAZI

È LA SOLUZIONE IDEALE PER L'ARREDAMENTO DI PICCOLI SPAZI, LOCALI ACCESSORI E POLIFUNZIONALI • IT'S THE IDEAL SOLUTION FOR FURNISHING SMALL SPACES, ACCESSORY AND MULTIFUNCTIONAL ROOMS.

LETTO ESTRAIBILE

COMUNQUE C'È SPAZIO PER UNO O DUE LETTI ESTRAIBILI SEMPRE PRONTI ALL'OCCORRENZA E PER UN PRATICO VANO PROFONDITÀ CM 60 DI SERVIZIO AL LETTO • THERE IS ENOUGH SPACE FOR ONE OR TWO EXTRACTIBLE BEDS ANYWAY, ALWAYS READY IF NECESSARY, AND FOR A PRACTICAL COMPARTMENT DEPTH 60 CM. AS A BED'S SERVICE.

THE BRIDGE CUPBOARD WITH MAXI HEIGHT





THE BRIDGE CUPBOARD WITH MAXI HEIGHT

UNA SOLUZIONE SMART CHE UNISCE PIÙ FUNZIONI, IDEALE SPACE SAVING DOVE TUTTO È A PORTATA DI MANO... DAL CORREDO TESSILE AI GIOCHI, AL COMPUTER, TUTTO IN UNA SOLUZIONE COMPATTA DA PERSONALIZZARE A PIACERE CON LE TEXTURE E LE FINITURE PIÙ ATTUALI

- A MULTIFUNCTIONAL SMART SOLUTION, IDEAL SPACE SAVING WHERE EVERYTHING IS AT HAND... FROM THE TEXTILE SET TO THE GAMES, TO THE COMPUTER, ALL IN A COMPACT SOLUTION TO CUSTOMIZE WITH THE TEXTURES AND THE MOST UP-TO-DATE FINISHES.

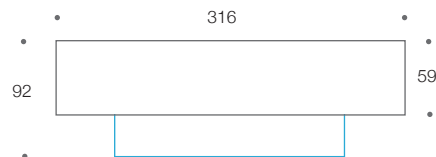

FINITURE - FINISHES (MELAMMINICI / LACCATI)
BIANCO, GRIGIO SCURO. TEXTURE CARBONCINO.

L'ARMADIO PONTE ALTEZZA MAXI





552

L'azienda, al fine di migliorare il prodotto, si riserva di apportare senza preavviso le modifiche e le migliori tecniche ritenute necessarie.

www.dielle.it

DIELLE UTILIZZA MATERIALI
ECO-COMPATIBILI NEL
RISPETTO DELLA NATURA.

DIELLE USES ECO-COMPATIBLE
MATERIALS IN RESPECT FOR NA-
TURE.

I PRODOTTI SONO REALIZZATI
CON MATERIALI E COMPONENTI DI
ALTA QUALITÀ E SONO
GARANTITI 5 ANNI.



ANNI
GARANZIA

PRODUCTS ARE MADE WITH
HIGH-QUALITY MATERIALS
AND PARTS AND COME WITH
A 5-YEARS WARRANTY.

I PRODOTTI SONO
INTERAMENTE REALIZZATI
IN ITALIA.

PRODUCTS ARE MADE
ENTIRELY IN ITALY.

R.&D./ DIELLE spa
A.D./ Promark/Comunicazione - MB-
IDEAZIONE/ Giambattista Ciceri
ARTBUYER/ Annalia Perego
STAMPA/ Industria Grafica S.I.Z. -VR-

DESIGN IN PROGRESS

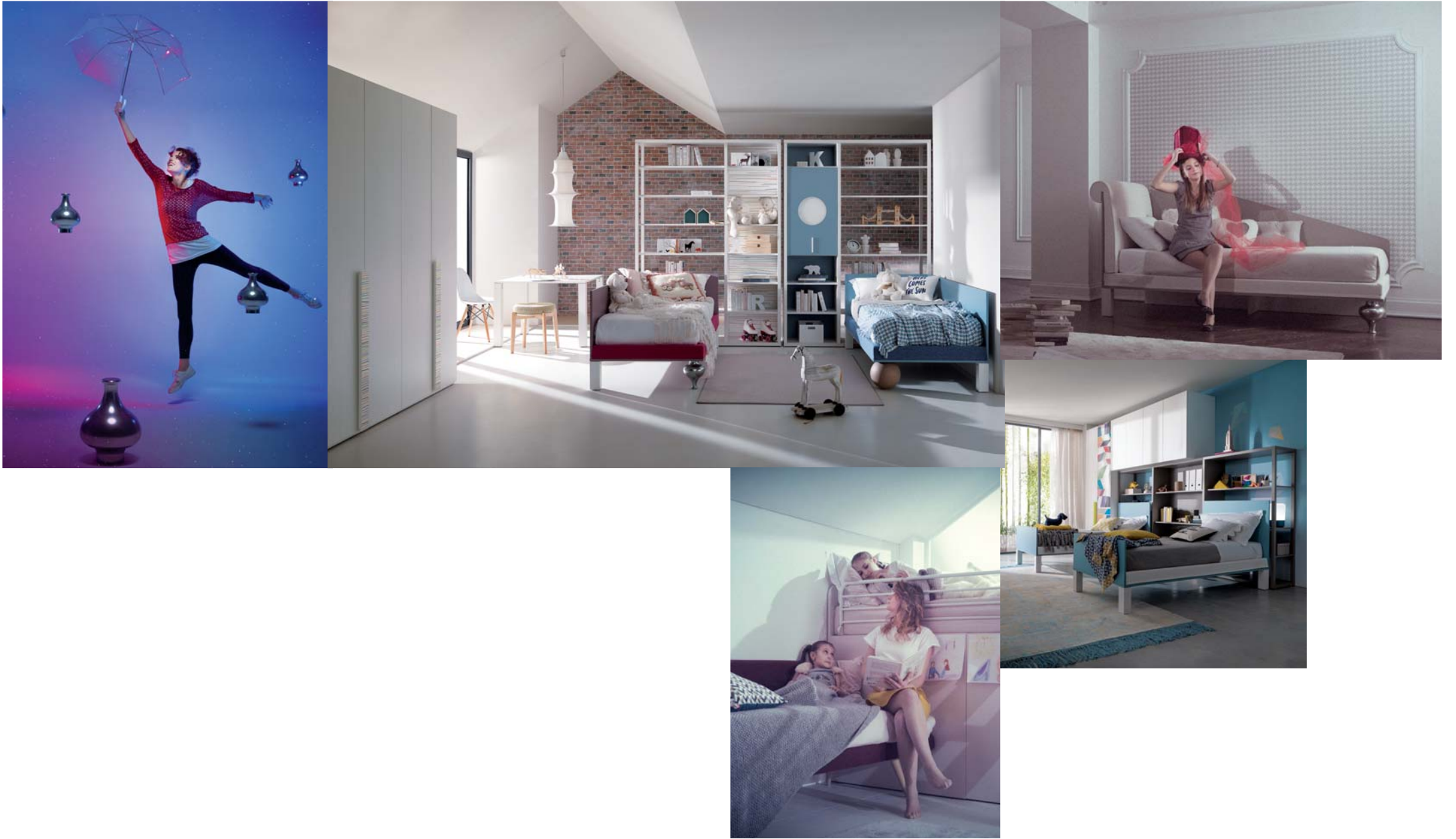

Sulle
Note
Di una
Melodia
Che il
Vento si
Porta
Via

Note come emozioni
tracciate sul rigo di nuove canzoni
si compongono
in una melodia
che il vento trasforma
in qualcosa
che sa di magia.









Pages 4-15 / *Composizione D 01* Sistema PaloAlto elementi aggregabili libreria a giorno attrezzata. Struttura e ripiani in nobilitato olmo perla, schienali texture tratto e laccato polvere, anta oblò laccato polvere, scrittoio e armadio laccato bianco, maniglie texture tratto. Letto Style con gamba sfera in legno vivo, letto Style con gamba trottola finitura argento, giroletto in tessuto sfoderabile. *Composizione D 01* PaloAlto system attachable elements equipped open bookshelf. Structure and shelves in melamine Olmo Perla. Tratto texture and Polvere lacquered backs, Polvere lacquered Oblò door, white lacquered desk and wardrobe, Tratto texture handle. Oriente lacquered Style bed with spherical leg, Avio lacquered Style bed with Trottola leg, bedframe in removable fabric coating.



Composizione D 02 Zona riposo con letto Style, Sistema PaloAlto elementi aggregabili libreria a giorno attrezzata con scrittoio integrato. Letto Style laccato polvere con giroletto rivestito in tessuto coordinato, gamba sfera in legno.
 Composition D 02 Resting area with Style bed, PaloAlto system attachable elements open bookshelf equipped with integrated desk.
 Polvere lacquered Style bed with coordinated fabric covered bedframe, raw solid wood spherical leg.



La collezione Style propone una vasta gamma di letti proposti nelle configurazioni più funzionali e rappresentative. Zona riposo con letto Style laccato oriente con gamba trottole in finitura argentata. Gli elementi ludici caratterizzano la proposta.
The Style collection proposes a wide range of beds available in the most functional and representative configurations. Resting zone with Oriente lacquered Style bed with silver finished Trottole leg. The playful elements characterize the proposal.



L'ARMADIO COORDINATO E GIOCO SO



Armadio coordinato laccato bianco con maniglie texture tratto. La semplicità degli elementi è valorizzata da un tocco creativo dato dai grandi maniglioni colorati che esprimono un'identità giocosa del prodotto.
Coordinated white lacquered wardrobe with Tratto texture handles. The elements' simplicity is enhanced by the creative touch of the big coloured handles that express a playful identity of the product.

Sogno
Di
Mezza
Notte
The
Dream
Come
True

Cenerentola cerchi l'amore
ora davvero apri il tuo cuore.
Vorresti volare e
sull'indifferenza ti metti a danzare.
Al centro della scena
una volta ci sei tu
e questo di certo
non si dimentica più.









Pages 16-27 / *Composizione D 03* Cabina Armadio XCAB profondità cm. 95 in olmo perla. Libreria terminale PaloAlto in nobilitato olmo naturale. Container letto contenitore apribile laccato ninfea, Letto divano imbottito rivestito in tessuto sfoderabile con gambe coniche legno. Scrivitoio ergonomico richiudibile laccato opaco creta e nobilitato olmo perla.
Composizione D 03 White and Corda lacquered XCAB wardrobe depth cm. 95. PaloAlto ending bookshelf in Natural Oak melamine finish. Container Pink lacquered openable storage bed, Upholstered sofa bed covered with removable fabric with wooden conical legs. Ergonomic closable desk light grey lacquered, white and natural elm melamine.



Container è un prodotto space saving dalle caratteristiche funzionali sorprendenti per la versatilità d'impiego in accostamento agli elementi di sistema: armadi librerie e letti, ma è perfetto anche in accosto alla cabina armadio XCAB che ha la modularità giusta per ogni dimensione e contesto d'arredo. Il piano letto è elevabile per consentire il facile accesso agli elementi contenitori integrati. Container is a space-saving product with amazing features for application versatility in combination with system elements: wardrobes bookshelves and beds, but it is also perfect placed beside the XCAB wardrobe which has the right modularity, right for every dimension and furniture context. The bed is liftable for an easier access of the lower storage elements.

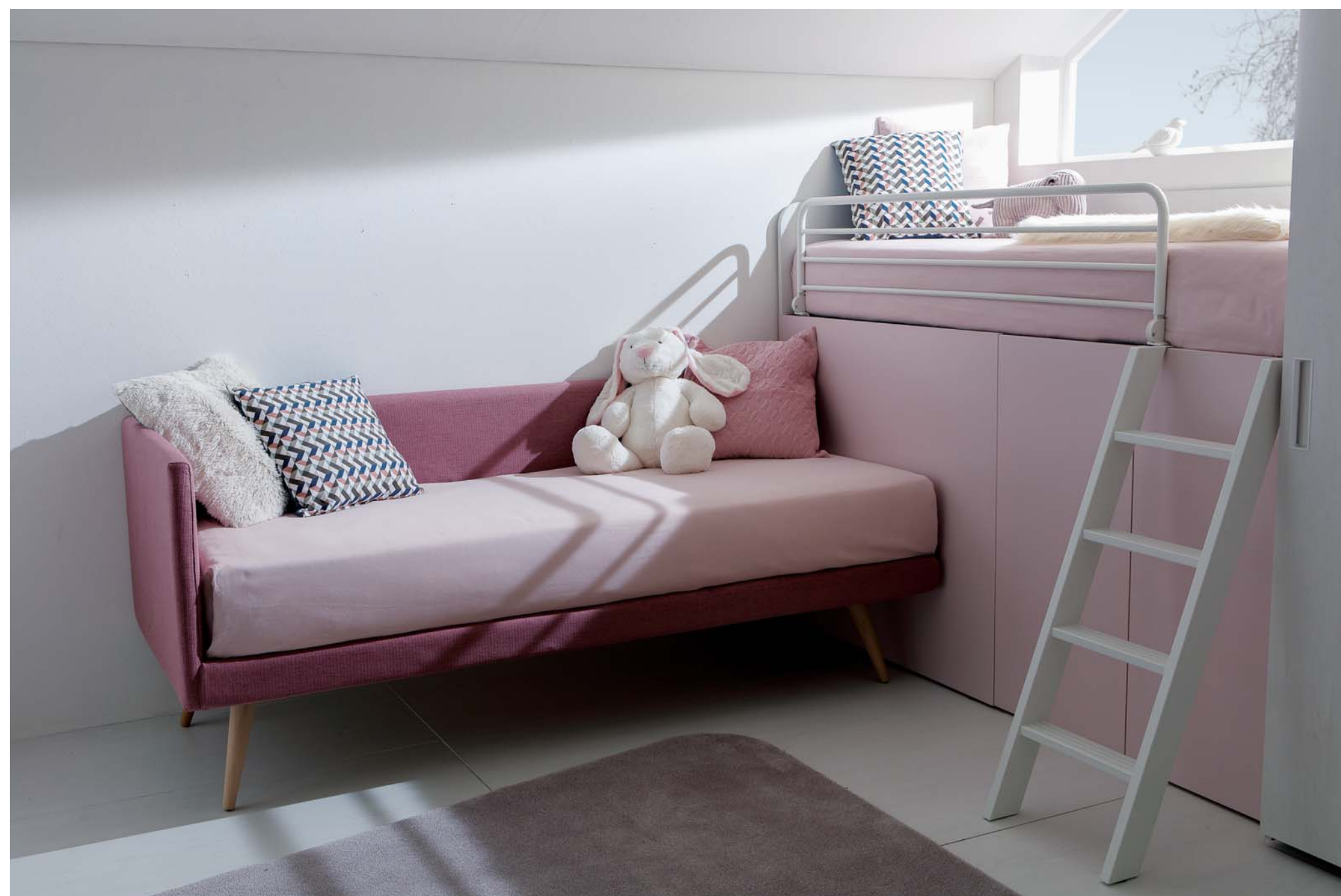

Il progetto Container ha le misure giuste per ogni ambiente. Grazie al letto posto nella parte alta consente di guadagnare ben due metri cubi di spazio che si rende immediatamente disponibile. Per questo si può definire un prodotto salvaspazio. Il suo design logico e funzionale lo rende prodotto ideale in accosto ai letti e ai sistemi Dielle, dando vita a soluzioni compatte e funzionali. The project Container has the right dimensions in every situation. Thanks to the bed located on the upper side it's possible to gain two cubic meters space, immediately available. For this reason this can be considered a space-saving product. Its logical and functional design makes it an ideal product in combination with the beds and the systems Dielle, creating compact and functional solutions.



Mera
viglio
samen
te...
Alice!

Dall'utopia dell'immaginazione
trasformerò in immagini i miei sogni.
Viaggiando in un luogo magico
dove affiorano nuovi colori.
È un bel posto dove ancorare
la barca dei pensieri
come scaturita dai miei desideri.









Pages 30-39 / *Composizione D 04* Sistema PaloAlto elementi aggregabili libreria a giorno attrezzata. Struttura e ripiani in nobilitato olmo perla, schienali laccato bianco, anta oblò laccato bianco. Scrivitoio dal disegno raccordato con gambe tornite in legno massello laccato bianco e creta, Letto Style laccato creta con parti imbottite rivestite in tessuto sfoderabile.
Composizione D 04 PaloAlto system combinable elements equipped open bookshelf. Structure and shelves in melamine Olmo Perla, white lacquered backs, white lacquered Porthole door. Bean-shaped desk with solid wood turned legs in white or light grey lacquered finish, Style bed light grey lacquered with padded parts clad in removable fabric coating.



La raffinata eleganza del disegno del letto Style, in queste pagine si rivela in tutto il suo charme. Un gioco di materiali e finiture preziose come l'argento, la trama tessile materica, la tenue laccatura opaca. Ma ancora una volta, a sorprendere è la scelta di un design di memoria che strizza l'occhio all'idea di uno stile classico senza tempo. The refined elegance of the Style Bed design shows all its charm in these pages. Materials and precious finishes such as silver, materic textile texture, soft matt lacquering. Yet one more time, what can surprise is choosing a memory design that looks to an idea of a classic style as old as time.



Armadio coordinato in nobilitato olmo perla con ante asimmetriche trapezoidali con maniglie diagonali. L'essenzialità del prodotto è arricchita dalla texture tratto applicata all'anta. La libreria terminale PaloAlto in nobilitato olmo perla ne completa la funzionalità nella perfetta integrazione degli elementi.
 Matching wardrobe in melamine Olmo Perla with asymmetric trapezoidal doors with diagonal handles. The simplicity of the product is enriched with the texture of the door. The ending bookshelf PaloAlto in melamine Olmo Perla completes its functionality in a perfect integration of the elements.





Nel segno di una personalità distintiva si possono cogliere diversi valori formali, espressione della propria identità, da interpretare a piacere. Così ciò che nelle pagine precedenti era fondamentalmente classico, ora si ripropone secondo un'idea di colore e di carattere più propositivo.

In the sign of a distinctive personality, different formal values can be welcomed, expressions of one's identity, for a personal interpretation. What in the previous pages was basically classic, now it is presented with an idea of color and a proactive role.

Dise
gnato
Sulla
Tua
Pelle

Per chi viaggia davvero
non conta la meta ma il viaggio.
Così non c'è solo il disegno in un tatuaggio.
Il viaggiatore senza conoscenza
è come un uccello senz'ali.

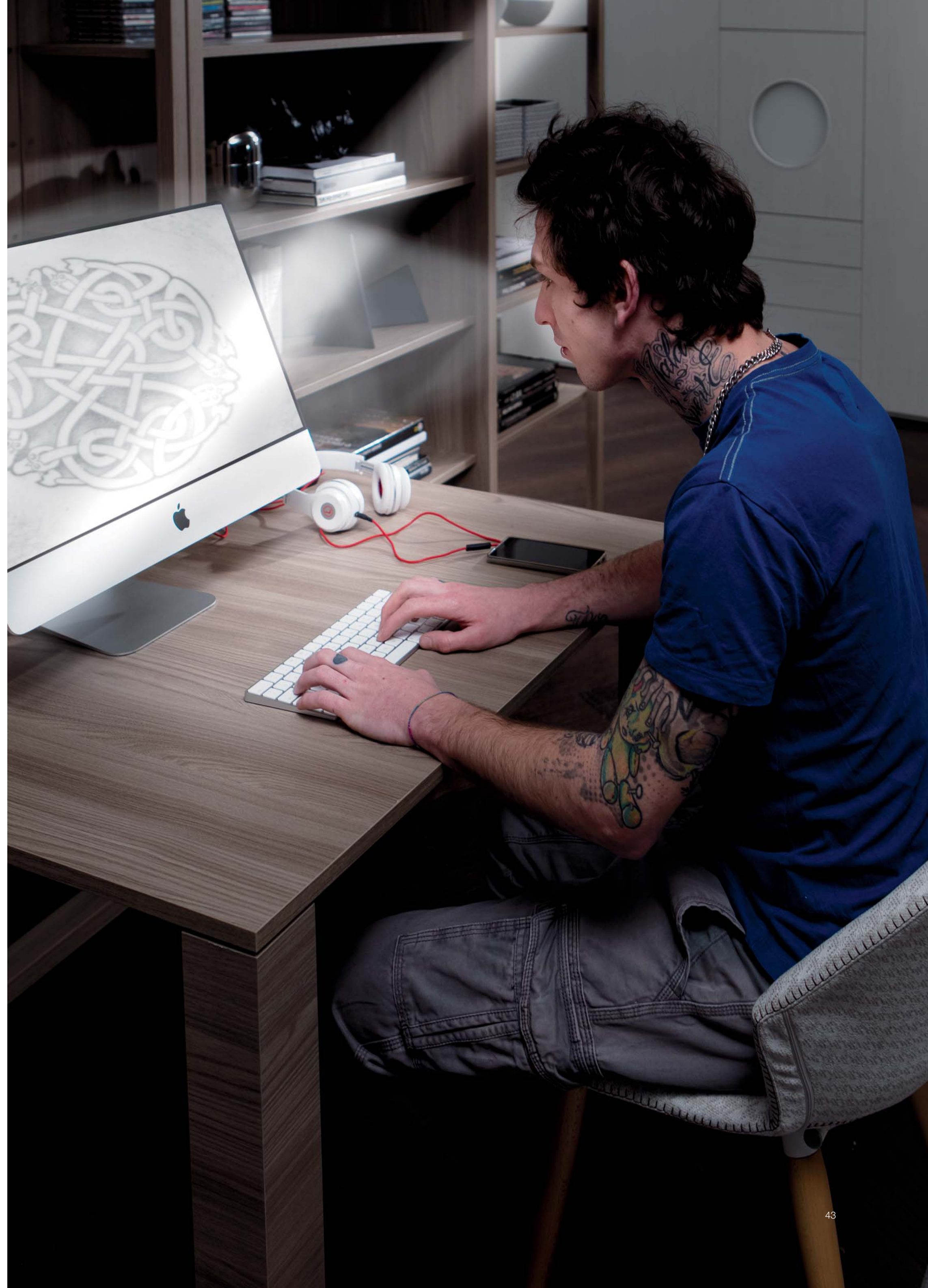



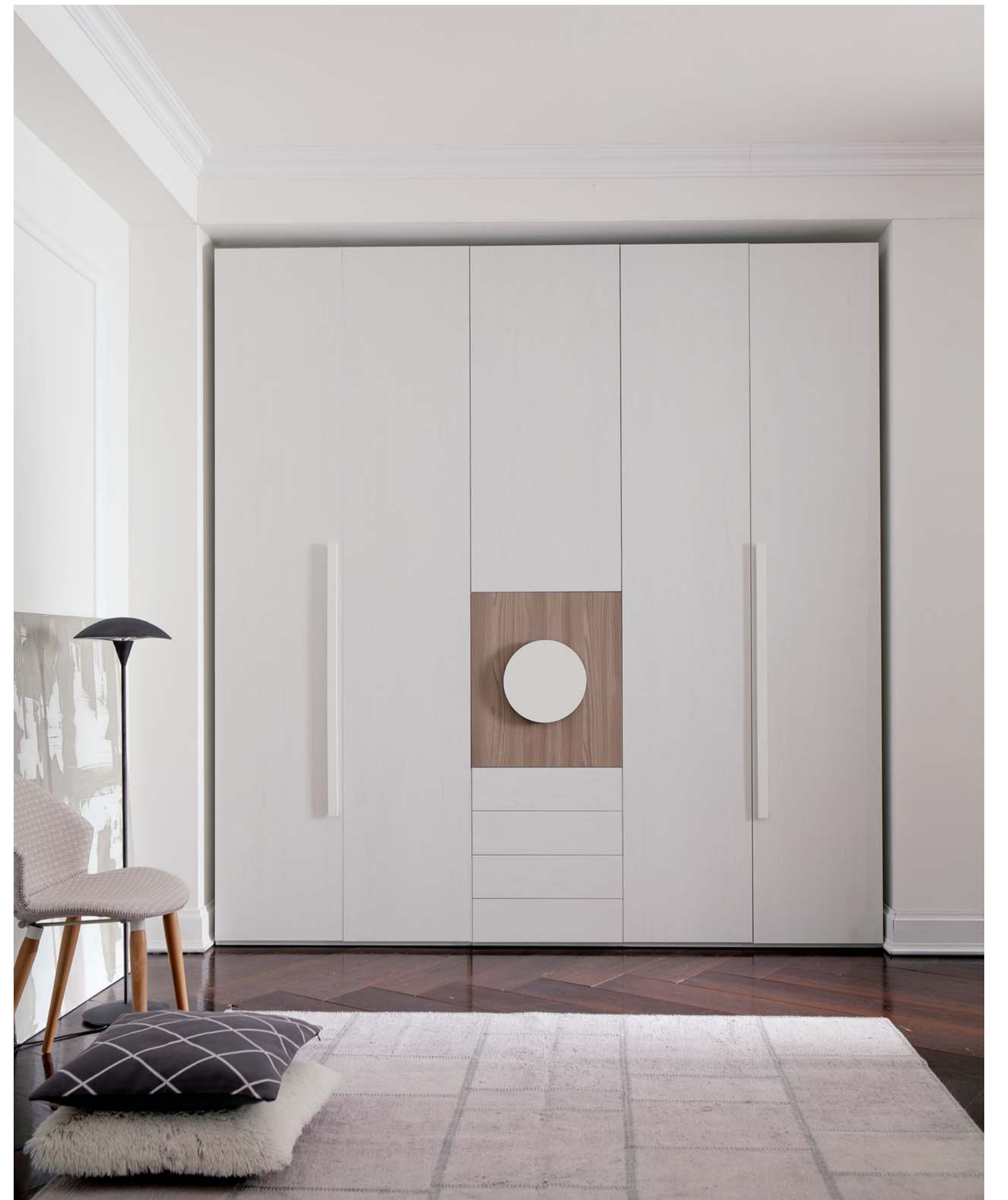

Pages 42-47 / *Composizione D 05* Sistema PaloAlto elementi aggregabili libreria a giorno attrezzata in nobilitato olmo cenere. Scrittoio dal disegno essenziale integrato alla libreria in nobilitato olmo cenere. Letto Style struttura nobilitato olmo cenere e tessuto sfoderabile. Armadio con oblò laccato bianco o con inserti nobilitato olmo cenere.
Composition D 05 PaloAlto system, combinable elements, equipped open bookshelf in melamine Olmo Cenere, desk with essential design connected to the bookshelf in white lacquered or in melamine Olmo Cenere. Style bed with melamine Olmo Cenere structure and removable fabric coating. Wardrobe with white lacquered Porthole door or with melamine Olmo Cenere inserts.



Collezione letti Style. Tante proposte per una scelta libera che spaziano dal design più innovativo al classico senza tempo. Morbide imbottiture tessili dialogano con il nobilitato essenza e con le raffinate laccature opaco. A ciascuno il giusto mix. Collection Style beds. Several proposals for a free choice, from the innovative design to the timeless classic. Soft textile paddings dialog with the melamine essences and the refined matt varnishes. To each his own mix taste.

Io
Sto
Con
Gli
Aqui
loni

Sospinte da un sospiro leggero
le nostre emozioni prendono il volo
nel cielo tracciano un segno di luce...
Che mi indica la rotta che non trovo.











Pages 54-58 / *Composizione D 06* Soluzione ponte con Sistema PaloAlto elementi integrati libreria a giorno attrezzata in laccato creta, letti Style laccato creta e senape con longherone rivestito in tessuto sfoderabile. Scrivitoio indipendente laccato prussia e senape. Texture cromatica aquilone a tutt'altezza. Pages 59-61 / Variante disposizione letti Style incrociati con scrittoio integrato in laccato giallo, creta, bianco malva e avio.

Composizione D 06 Overhead wardrobe solution with PaloAlto system, integrated elements, equipped open bookshelf in lacquered Creta, Style beds white lacquered with padded bed-sides in removable fabric coating. Independent desk white lacquered with white and yellow lacquered shelves. Arlecchino chromatic texture shown at full-height. Pages 59-61 / Variation with corner arranged beds with integrated desk in yellow, creta, white, malva and avio lacquering.







Dielle è un'azienda propositiva e innovativa come dimostra l'attenzione alle tematiche progettuali, mai banali, sempre attraversate da una sottile ironia. Sono proposte ludiche, vicine alla psicologia dei più giovani... Un mondo fatto di una poetica espressiva che si rivela in forme dal design fresco e divertente, in un gioco di stickers, texture e di rimandi al mondo del fumetto. Dielle is a proactive and innovative company as demonstrated by the attention to the design themes, never dull, always crossed by a subtle irony. Entertaining proposals, in line with the psychology of the youngest... A world made of an expressive poetics which becomes apparent in shapes with fresh and funny design, in a game of stickers, textures and references with the comics' world.

L'azienda, al fine di migliorare il prodotto, si riserva di apportare senza preavviso le modifiche e le migliorie tecniche ritenute necessarie.

DIELLE
GRUPPO DOIMO

DIELLE SPA
Via Montegrappa, 142
31010 Mosnigo di Moriago -TV- Italy
Tel. +39 0438 9091 - Fax +39 0438 842188
info@dielle.it

www.dielle.it

R.&D./ DIELE spa
A.D./ PromarkComunicazione -MB-
IDEAZIONE/ Giambattista Ciceri
PHOTO/ Punto Zero - Stefano Frigerio
ART-BUYER/ Amalia Perego
CONSULENZA STILISTICA/ Teatro della Moda
STAMPA/ Industria Grafica S.L.Z. -VR-