

NEW POINT OF VIEW

biba
SALOTTI

Biba Salotti fondata nel 1980 da Francesco Miari è un'azienda italiana affermata nel settore degli imbottiti di design.

La filosofia che caratterizza l'azienda è quella dell'artigianalità made in italy.

Ogni prodotto nasce con originalità, si sviluppa con passione e viene prodotto con standard di qualità altissimi.

Biba Salotti considera la ricerca e la sperimentazione un elemento strategico nella politica di sviluppo aziendale.

I prodotti Biba Salotti vengono realizzati nella sede aziendale situata a Parma, un'azienda che si estende su un'area di 23000 mq di cui 10000 mq sono adibiti alla produzione.

Tutti gli imbottiti vengono realizzati con materiali selezionati che garantiscono l'alta qualità, confermando Biba Salotti un marchio riconosciuto in Europa, America e Medioriente e Asia.

Biba Salotti was founded in 1980 by Francesco Miari. It is an Italian company, successful in the sector of soft furnishings.

The philosophy that characterises the company is craftsmanship MADE IN ITALY.

Each product is created with originality, is developed with passion and is reproduced with exceptionally high quality standards.

Biba Salotti considers research and experimentation to be a strategic element in the company's development.

Biba Salotti products are created at the company headquarters in Parma, a facility that covers an area of 23,000 square metres, 10,000 of which are used for production.

All the soft furnishings are made from selected materials that guarantee the high quality, ensuring that Biba Salotti is a brand recognised in Europe, America, Middle East and Asia.

biba
S A L O T T I

WWW.FACEBOOK.COM/BIBASALOTTI



INDICE

INDEX

ADELAIDE	142	MAX	096
AGADIR	180	NICK	018
AIRON	184	NINNA	200
ALEX	084	NANNA	201
ALTEA	150	OTTO	194
AVATAR	100	PIUMA	162
BELLO	040	PLANO	144
BOSTON	120	PLAY	104
BRAD	134	PUFFO	172
BRAVO	006	PUFFO LINE	172
CHARLIE	126	RALPH	166
CLORINNE	160	SETTE	192
DIECI	196	SURF	190
DISCOVERY	170	SILVER	066
EGO	174	TAG	038
FREEDOM	028	WILLY	161
FROG	054	ZENO	088
HOLÀ	188		
JOY	078		
LINK	058		
MADISON	198	I MATERIALI	202
MASTER	114	SCHEDE TECNICHE	208

BRAVO

Ci piace il sogno in tutta la sua spontaneità e la realtà in tutta la sua complessità.
Ci piace l'immaginazione e la sorpresa nel mettere insieme le cose.
Bravo dà forma e volume ad un progetto da osservare da diverse prospettive: il bracciolo disegna un profilo inedito e i cuscini definiscono i volumi accoglienti.

*We love dreams in all their spontaneity and reality in all its complexity.
We love imagination and surprising ways of putting things together.
Bravo give shapes and volume to a design to be looked at from different perspectives: the arm forms an unusual profile and the cushions define welcoming volumes.*













NICK

Energia e carattere. Un progetto capace di valorizzare la relazione del prodotto con l'ambiente. Nick è l'espressione della connessione tra comfort e design in sintonia con le esigenze della quotidianità contemporanea.

Energy and personality. A project capable of enhancing the relationship of the product with the space. Nick is the expression of the connection between comfort and design, in harmony with the contemporary everyday life's need.











FREEDOM

Voglia di libertà e voglia di condivisione. Il design diventa strumento di comunicazione personale.

Freedom è un progetto coinvolgente con un dna creativo 100% made in italy: ampie sedute per non avere limiti di movimento e molteplici composizioni per assecondare un'indole aperta e vivace.

A desire for freedom and a desire to share: design becomes a personal communication tool. Freedom is an engaging design with a 100% made in italy dna: wide seats that give room for movement and multiple compositions to indulge an open, lively nature.











TAG

Ispirazione dal passato e desiderio di unicità per Tag. Una poltrona dall'aspetto formale seducente e rigoroso nello stesso tempo. La creatività trova espressione nell'uso consapevole di materiali diversi, capaci di definire una precisa identità.

Inspiration from the past and uniqueness' desire for Tag. An armchair with a charming and rigorous formal aspect at the same time. Creativity finds expression in the conscious use of different materials, capable of defining a clear identity.



BELLO

Infinite possibilità di combinazioni capaci di emozionare per un progetto personale capace di esprimere la voglia di cambiamento e di versatilità.

Infinite exciting combination possibilities for a personal style that expresses the desire for change and versatility.









DEFINIRE IL TUO NUOVO
STILE È SEMPLICE: PUOI
SCEGLIERE SCHIENALI DI
MISURE UGUALI OPPURE
DIVERSE, COLORI TONO
SU TONO OPPURE A
CONTRASTO.
ACCOSTARE VOLUMI
DIVENTA UN GIOCO
E DEFINISCE
NUOVE FORME.

*Designate your new style is simple: You can
choose backs of equal or different sizes, tone-
on-tone or contrasting colors. Put volumes
near each other becomes a game and defines
new shapes.*







FROG

Eleganza poetica ed ergonomia accogliente sono le caratteristiche che definiscono il carattere forte di Frog. Il progetto nel segno della ricerca estetica e della funzionalità, trova il suo completamento nell'accostamento del pouff alla poltrona.

Poetic elegance and comfortable ergonomics are the characteristics which define Frog's strong personality. In the name of aesthetic research and functionality, this project finds its completely in the combination of the pouf with the armchair.





LINK

L'armonia si costruisce nel design e si definisce nei dettagli...e tutto diventa un gioco: scegliere la chaise longue oppure l'angolo conversazione; la cucitura tono su tono oppure con filo a contrasto; la forma e i volumi dei cuscini più glamour.

Harmony is in the design and defined in the details ... and everything becomes a game: choose the chaise longue or the conversation corner; tone on tone stitching or with contrasting thread; the most glamorous cushion shapes and volumes.

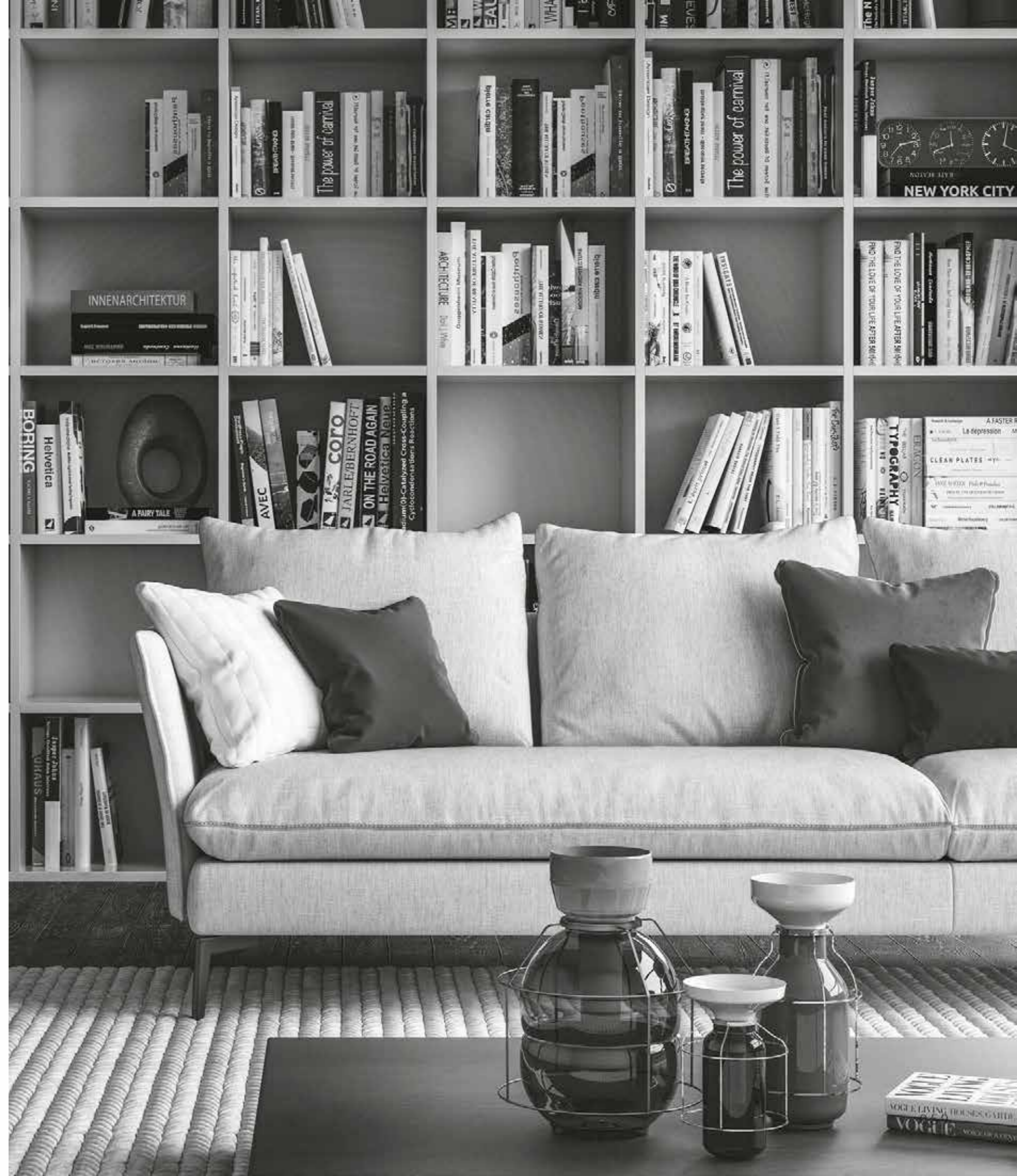





FINALMENTE IL FILO DI
UN NUOVO RACCONTO DA
VIVERE NEI TONI CHE CI
APPARTENGONO DAVVERO.
GLI ABBINAMENTI DEI
COLORI SI ESPRIMONO
SENZA CONVENZIONI:
CONTRASTO OPPURE
TONO SU TONO?

*Stitching finally the thread of a new story to
experience in shades that truly belong to us.
colour combinations express themselves
without conventions: contrast or tone on tone?*



SILVER

Alla scoperta della dimensione più creativa di un progetto che appare sorprendentemente dinamico e confortevole.
Light o large: l'aspetto estetico cambia con la scelta del bracciolo nella larghezza che si preferisce.

*Discovering the most creative dimension of a project that seems unexpectedly dynamic and comfortable.
Light or large: the aesthetic aspect changes with the choice of the armrest's width you prefer.*





L'uomo contemporaneo ha il desiderio di percorrere nuove strade capaci di stupire nel momento giusto.
Un gesto semplice per ribaltare una comoda seduta in funzionale piano d'appoggio.

Contemporary man with the desire to travel new roads able to surprise at just the right moment, a simple act to turn a comfortable pouff into a functional support base.









L'identità di Silver asseconda la sua anima versatile e ne valorizza la relazione con il luogo grazie alla possibilità di scegliere il colore del piano del tavolino.

Silver's identity supports its versatile soul and enhances its relationship with the room thanks to the possibility of choosing the color of the table top.



JOY

Joy regala l'occasione di interpretare lo spazio e asseconda la moderna ricerca di ambiente dinamico, attraverso un progetto capace di esaltare il valore estetico e funzionale di ogni singolo pezzo. Volumi importanti e ampia profondità di seduta con molteplici possibilità di componibilità in grado di suggerire una scelta senza compromessi.

The aesthetical value and functionality of each element give you the possibility of interpreting the space around you, favouring modern search for dynamic rooms. Important dimensions and deep seats, a wide choice of elements which can be combined together allow various compositions without compromise.







Ampi spazi di seduta e componibilità estremamente versatile per creare una dimensione nuova, un luogo dove mettere in ordine i pensieri, progettare nuove esperienze e condividere una nuova estetica funzionale e rilassante.

Plenty of seating space and extremely versatile modules create a new dimension, a place to collect your thoughts, plan new experiences and share the pleasure of practical, comfortable good looks.



ALEX

Ampie ma leggere sedute, quasi sospese su agili piedini in metallo che fanno da cornice alle linee avvolgenti della struttura che accoglie come un "guscio" morbidi ed invitanti cuscini. Questi sono dettagli creativi di un'estetica che trova nell'essenzialità la sua massima espressione.



Wide but light seats as they were flying over the slender metal legs, which together with metal frame enclose, as a shell does, soft and inviting cushions. Creative details, pure aesthetics, that come out from essentiality.





ZENO

Il desiderio di unicità è sempre forte e cresce con l'intento di soddisfare sogni ed ambizioni. Nel design si traduce in una nuova ricerca stilistica mirata ad interpretare in modo originale e con massima libertà spazio e volume.

The desire for uniqueness is ever stronger and grows with the intention of satisfying dreams and ambitions. In design it translates into researching new styles aimed at interpreting space and volume in original ways and with the greatest freedom.









MAX

Rigore e serietà si trasformano in accogliente e morbido senso di comfort. I dettagli della geometria, la scelta del piede e il suo abbinamento cromatico con il rivestimento valorizzano il rapporto di Max con il contesto del luogo.

Strictness and seriousness are transformed into a welcoming and soft sense of comfort. The geometry's details, the choice of the foot and its chromatic combination with the upholstery enhance Max's relationship with the context of the place.





AVATAR

Equilibrio ed armonia per creare un modello che fa parlare di sé. Le finiture di cuscini e sedute e gli eleganti profili in acciaio dei piedi definiscono un progetto con una forte identità contemporanea.

Balance and harmony creating a model that makes people talk about itself. The finishes of the cushions and seats and the elegant steel profiles of the feet define a project with a strong contemporary personality.



AVATAR È UN PROGETTO
DA VEDERE, DA TOCCARE
E SOPRATTUTTO DA VIVERE.
È LA RISPOSTA
ALL'EVOLUZIONE DEI
MODI DI ABITARE.

*Avatar is a project to see, to touch and above
all to live. It is the answer to the ways-of-living
evolution.*



PLAY

Una dote dinamica che conduce a ciò che per Biba è un punto fermo: il comfort. Le chance di componibilità si moltiplicano, così come la libertà di godersi ogni singolo particolare. Il bracciolo è disponibile nella misura 26 cm e nella versione Play Light, 20 cm.

The wide choice of modular units increases as the possibility of enjoying each detail. A dynamic characteristic that recalls one of Biba's main points comfort. The armrest is available in size 26 cm and in size 20 cm in the Play Light version.



PLAY



PLAYLIGHT







Ogni momento di relax ha bisogno della giusta mossa: basta un gesto semplice per alzare il poggiatesta, e un veloce movimento per ampliare la seduta e infine un tecnologico click per alzare il poggiapiedi. Play è un progetto in continua evoluzione, capace di soddisfare le tue esigenze e soprattutto assecondare il tuo stato d'animo

Each moment of relaxation needs the right movement: a simple gesture is all that's needed to raise the headrest, a quick flick to widen the seat, and finally, a technological click to raise the footrest. Play is a project in continual evolution, able to satisfy your needs and above to indulge your mood.





PLAY

ARMCHAIR



MASTER

Design dinamico, linee rigorose, volumi invitanti, Master è capace di proporsi con un'estetica equilibrata per divenire sicuro protagonista di ogni ambiente.

Thanks to its dynamic design, rigorous lines and inviting shapes, Master embodies a balanced sense of aesthetics, immediately becoming the main protagonist in every room.







Con un semplice gesto possiamo godere del massimo comfort. L'avanzamento della seduta e il ribaltamento del poggiatesta favoriscono la conquista di una posizione completamente dedicata al relax.

With a simple movement you can enjoy maximum comfort. By moving forward seat cushions and lifting up headrests you gain additional space for your complete relaxation.



BOSTON

Boston si presenta semplicemente confortevole e diventa la risposta alla nostra incontrollabile voglia di cambiamento.

Boston is simply comfortable. It becomes the answer to our exquisite need of changes.





IL DESIGN RAZIONALE
EVIDENZIA GLI AMPI
VOLUMI E LA DINAMICA
DEL MOVIMENTO DELLO
SCHIENALE. BOSTON È
CAPACE DI INTERPRETARE
LO SPAZIO SEGUENDO
LE ESIGENZE SEMPRE
DIVERSE CHE SCOPRIAMO
NEL VIVERE QUOTIDIANO.

*Rational design highlights spacious seats and
dynamism of backrest movement. It's able
to follow the different space needs that we
discover in everyday life.*



CHARLIE

La possibilità di godersi il proprio spazio in libertà diventa un sogno realizzato con Charlie. Lineare eppure originale, semplice ma unico. L'armonia dinamica è il suo vero punto di forza.

The chance to freely enjoy your own space becomes a dream come true with Charlie. Linear yet original, simple yet unique. Dynamic harmony is its true strong point.









BRAD

E' bello trovare conferma dei propri desideri in spazi reali, dove vivere in relax il vivere quotidiano. Il sofa evita il puro narcisismo a favore di un design funzionale e di una forte identità personale.

It's good to find your desires met in real spaces where you can relax and enjoy the pursuits of everyday living. The sofa avoids pure narcissism in favour of a practical design and a strong personal identity.









ADELAIDE

La stessa anima è capace di disegnare due storie diverse per carattere e attitudine: contemporanea e sofisticata.

The same soul tells two stories with different personalities and attitudes: contemporary and sophisticated.



PLANO

Sentirsi unici è un'esigenza comune, occorre riuscire ad immaginare nuovi scenari dinamici e ricercati: il ritmo delle cuciture diventa così il dettaglio che rende originale il total white.

Feeling unique is a common need, you have to be able to imagine new, dynamic scenarios: so the rhythm of the stitching becomes the detail that makes total white original.





LO SPAZIO CHE ABITI
OGGI PARLA DI TE
CON TONI CHE
PUOI SCEGLIERE.
OGNI COLORE
RACCONTA UNA STORIA.



*Your living space today speaks about you
with the tones you can choose. Each color
tells a story.*



ALTEA

Forme che hanno una storia da raccontare, capaci di dare una nuova interpretazione di un luogo e diventare protagonista di una storia esclusiva e quotidiana: il design si esprime con originalità.

Severe and rigorous as they may look at glance, armchairs Max actually give you a cozy and soft sensation as they wrap around you with the deep seat, expression of studied philosophy of geometrical relaxation.











CLORINNE



WILLY



PIUMA

Un'estetica di design non invadente, discreta e accogliente, dove morbidi cuscini lievemente appoggiati alla struttura predispongono l'animo a vivere al meglio i movimenti di relax.

Discreet, welcoming design of soft cushions placed over the sofa's structure invite you to reach complete relaxation.





RALPH

Per diventare grandi a volte è necessario uno sguardo al passato. e così le nuove generazioni hanno bisogno con rinnovata consapevolezza della competenza dei maestri, capaci di unire sapere e mestiere in accostamenti unici ed originali.

To become great it's sometimes necessary to look at the past, and new generations need renewed awareness of the skill of masters able to unite know-how and craftsmanship in unique and original combinations.





DISCOVERY

Il concetto di spazio è in continuo cambiamento e gli oggetti mutano la loro funzione in modo rapido e originale. Discovery è un elemento che vive in modo trasversale, assecondando l'esigenza del quotidiano.

The concept of space is constantly developing and the objects change their function quickly and originally. Discovery is an element that lives in a crossing way, supporting the need of everyday life.



POUFF

Il pouff anima l'ambiente con colori e forme diverse: da solo oppure accostato ai divani, diventa un elemento d'arredo capace di creare atmosfere inaspettate in spazi sofisticati, contemporanei e classici.

The pouff brings the space to life with different colors and shapes: on its own or combined with sofas, it becomes a furnishing element capable of creating unexpected atmospheres in sophisticated, contemporary and classic living.



— PUFFOLINE

PUFFOLINE —

— PUFFO

EGO

SOFA-BED

Design dinamico, linee rigorose, volumi invitanti, Ego è capace di proporsi con un'estetica equilibrata per divenire sicuro protagonista di spazi destinati al relax quotidiano.

Dynamic design, rigorous lines and attractive shapes. Ego's balanced aesthetics becomes the main protagonist of the space for your everyday comfort.







AGADIR

SOFA-BED

Assoluto comfort di seduta. Linee raffinate e semplici per un protagonista trasformista: con un gesto la seduta diventa un vero letto matrimoniale. Agadir è la risposta alle esigenze del vivere contemporaneo.

Absolute sitting comfort. Refined and simple lines for a quick-change protagonist: with just one movement, the seat becomes a real double bed. Agadir is the answer to the requirements of contemporary living.





AIRON

SOFA-BED

Airon e' capace di mostrarsi glamour ed aristocratico al tempo stesso. Le sue forme sinuose e il design ricercato ne sottolineano i punti di forza, rendendolo pura espressione di accoglienza di giorno e nido di estremo comfort di notte.

Airon appears to be glamour and aristocratic at the same time. Sinuous shapes and refined design are the Airon's best characteristics that make the sofa pure expression of hospitality during the day and nest of comfort at night.





HOLÀ

SOFA-BED

Holà si mostra subito un divano dal carattere moderno e armonioso, capace di svelare all'occorrenza un'anima comoda e rilassante grazie a un materasso ortopedico a molle h. 15 cm.

Holà' at a glance a sofa with a modern character when needed, it reveals its comfortable and relaxing soul, thanks to its orthopaedic mattress with springs 15 cm h.



SURF

SOFA-BED



Design dinamico, linee rigorose, Surf è capace di proporsi con un'estetica equilibrata per divenire sicuro protagonista di ogni ambiente.

Thanks to its dynamic design, rigorous lines and inviting shapes Surf embodies a balanced sense of aesthetics, surely becoming main protagonist in every environment.



SETTE

SOFA-BED



La geometrica sobrietà della linea cela il segreto di un letto comodo come il divano che lo custodisce, dalla personalità estremamente confortevole perché avvalorata da un'imbottitura di grande pregio.

The geometric sobriety of its lines conceals the secrets of a bed, as much comfortable as the sofa in which it is contained, an extremely comfortable personality made of paddings of great quality.



OTTO

SOFA-BED



Romanticismo, eleganza e calore delineano la sua chiara identità classica, che non rinuncia alla seduzione di linee morbide ed accoglienti, garantendo un comfort intenso come i momenti che è destinato a vivere.

Romanticism, elegance and warmth outline its classic identity without denying the seduction of soft and cozy lines that guarantee an intense comfort for the precious moments of your life.



DIECI

SOFA-BED



Con un semplice gesto possiamo godere del massimo comfort. Dieci svela un'anima comoda e rilassante grazie a un materasso ortopedico a molle di cm 15.

With a simply movement you can enjoy maximum comfort. Dieci reveals its comfortable and relaxing soul, thanks to its orthopaedic mattress with springs 15cm h.



MADISON

SOFA-BED

Un meccanismo sofisticato ed una stessa scocca base sono "l'anima" di Madison tipo 4,3,2 e 1. Anima che prende forma in quattro differenti modelli di compiuta armonia ed equilibrato design e offre spazio ad un comodo materasso ortopedico a molle di cm 15. Braccioli e piedini variamente abbinati sono dettagli determinanti che sanciscono la definizione estetica del Madison: attuale, classico, generoso o sinuoso.

A sophisticated mechanism and the same frame are the "heart" of Madison 4,3,2, and 1. A heart taking shape in four different models of perfect harmony and well-balanced design, offering storage for pillows and an orthopaedic mattress of cm 15. Armrests and feet to be combined at choice become determining details that enforce the Madison's aesthetics: up-to-date, classic, generous or sinuous.



TIP01/TYP1



TIP02/TYP2



TIP03/TYP3



TIP04/TYP4



NINNA

ARMCHAIR-BED



NANNA

POUFF-BED



MATERIALI

MATERIALS



LEGNO

IL MATERIALE PIÙ PREZIOSO



Biba Salotti sceglie per la realizzazione dei prodotti della propria azienda, legno di alta qualità nella consapevolezza del valore assoluto di questo materiale prezioso, impegnandosi a razionalizzarne l'utilizzo durante il ciclo produttivo ed avvalendosi di collaboratori che verificano la provenienza del legno da foreste sottoposte a opere di disboscamento controllato in modo da non compromettere il patrimonio forestale.

I legni impiegati per la costruzione delle parti strutturali portanti sono di multistrato di pioppo, per le parti di chiusura utilizziamo legno compensato e faesite. Per le parti a vista come piedi o mobiletti di complemento utilizziamo legni nobili quale faggio, wenghè, rovere o ciliegio. La pluriennale esperienza artigianale e la conoscenza delle moderne tecnologie permettono la realizzazione di strutture decisamente solide, ottime basi di partenza per la costruzione di un soggetto imbottito confortevole ed ergonomico.

Wood, the most valuable material. Biba Salotti chooses wood of the highest quality in accordance with its value. Our aim is to optimize its consumption during production cycle and we use wood taking care it comes from controlled deforestation area, in order to protect our forest heritage. Wood used for structural parts is of multilayer poplar, while for the closing parts is of plywood and hardboards. All visible parts, such as feet or design components are of noble woods such as beech, wenge, oak or cherry. The long lasting experience of handmade working and knowledge of the most up-to-date technologies allow the realization of surely strong structures that is a perfect starting point for the setting of a comfortable and ergonomic upholstered sofa.



RELAX

L'EQUILIBRIO DELL'ANIMA



Gli imbottiti Biba Salotti sono realizzati con materiali naturali ed innovativi selezionati secondo i più rigorosi criteri di qualità, sicurezza e solidità. Queste caratteristiche e la cura artigianale dei dettagli costruttivi determinano il pregio e la durata nel tempo di ogni prodotto. Nelle nostre progettazioni viene privilegiata la ricerca del relax, equilibrio dell'anima.

La struttura dei nostri imbottiti viene ricoperta da materiali a diversa densità, selezionati a seconda della posizione in cui vengono impiegati valutando le necessità della nostra spina dorsale al fine di non costringerla in posizioni scorrette in modo da non danneggiare muscoli articolazioni e legamenti. Il sistema di molle all'interno dei cuscini di seduta assicurano la massima comodità essendo comunque protette da una stratificazione, che le rende impercettibili pur garantendo la resistenza nel tempo.

La comoda accoglienza dei nostri cuscini e la sensazione di comfort è determinata dal giusto ed equilibrato dosaggio tra piume d'oca e d'anatra (prodotto accuratamente lavato, sterilizzato ed anallergico) che avvolgono un'anima di poliuretano a spessore differenziato; il tutto racchiuso in una candida fodera di puro cotone.

Comfort, soul balance. Biba Salotti sofas are made of natural and innovative materials selected by manufacturer according to criteria of quality, safety and solidity. Such characteristics combined with accuracy of traditional working methods make each Biba's sofa precious and durable. We favour research of relax, balance of soul in all our design. Wood structure of our upholstered sofa is covered by materials with different density to grant correct and healthy backbone position when sitting. We value its position in order to get a comfortable sitting without damaging articulations, muscles and ligaments. The springs' system located inside seat cushions is covered by a thick protection layer which grant their durability and comfort of seating. The filling of our backrest's cushions comes from a correct and balanced ratio between goose and duck downs (carefully washed, sterilized and hypoallergenic) with a polyurethane foam of different thicknesses. All our cushions are finally covered by a white cloth made of pure cotton.



I DETTAGLI

LA NOSTRA FORZA

I dettagli sono il punto di forza della nostra produzione, in particolare il sistema antiscivolo è stato studiato per garantire al cuscino di seduta stabilità e ordine.

Le cuciture rappresentano un passaggio fondamentale, concettualmente semplici, in realtà esse si declinano in una miriade di variabili, cambiate a seconda della posizione in cui intervengono. A livello estetico esse rappresentano un elemento di ricercatezza.

La lavorazione applicata alla produzione dei nostri modelli si ispira a criteri artigianali, così come un tempo, ancora oggi i tessuti utilizzati per il confezionamento vengono cuciti seguendo un procedimento antico indispensabile per salvaguardare il manufatto da imperfezioni.

Details, our strength. Details are our strength, in particular our system of skid stopping, which ensures stability and order of cushions. Seams are basic even though very simple. In reality they are so numerous and versatile according to their different settings. They represent a refinement object at aesthetic level. Production cycle of our models is ruled by criteria of handmade working, the same of many years ago. Today we use fabrics which are sewn following an ancient process, so important in order to safeguard our products from defects.



TESSUTI

ESPRESSIONE DI QUALITÀ

Biba Salotti è consapevole della necessità di offrire alla clientela più esigente la possibilità di scegliere il rivestimento in una vastissima collezione di tessuti. Ogni modello diventa così una nuova interpretazione attraverso la selezione di colori accesi, fibre e toni naturali, o tessuti tech e colori di tendenza. L'azienda si impegna con professionalità a studiare la compatibilità tra le caratteristiche del rivestimento e le peculiarità tecniche ed estetiche del soggetto da rivestire.

Ogni materiale presente in collezione è stato sottoposto a test che ne individuano e garantiscono le caratteristiche di qualità, resistenza e durata alle abrasioni. Ogni articolo venduto viene accompagnato da una scheda tecnica riguardante il tessuto utilizzato per la realizzazione del divano, nella quale vengono riportate le norme specifiche per la manutenzione e la composizione del tessuto.

Fabrics, quality expression. Biba salotti knows very well that it is necessary to offer its customers a wide range of fabrics to choose for their sofas' covering.

In this way, every model becomes a unique piece, according to the selection of bright colours, natural fibres and shades, or high tech fabrics and fashion colours.

Bibasalotti studies carefully the characteristics of covering in accordance with technical and aesthetic features of the sofa.

Every material of our collection has been tested to guarantee high quality, resistance and abrasion resistance. Our sofa is sold with a technical datasheet containing details of the used fabric and its composition and specific maintenance instructions.



SCHEDE TECNICHE

TECHNICAL FEATURES





AGADIR

Pagina 180

Design:
Studio Archimeta

S O F A - B E D



STRUTTURA

Struttura in legno e multistrato imbottita in poliuretano a quote differenziate e rivestita in resinato accoppiato dello spessore di 10 mm.

TELAIO

Telaio sotto i cuscini di seduta in multistrato per le versioni fisse.

SEDUTA

Cuscini di seduta in poliuretano densità minima 30 HR rivestiti da una falda Dacron con inserto centrale a molle.

SEDUTA - versione letto

Cuscini di seduta in poliuretano densità minima 30 HR rivestiti da una falda Dacron.

SCHIENALE

Cuscini schienale 100% in piuma naturale depolverizzata, lavata e sterilizzata, a camere separate orizzontalmente, con inserto in poliuretano interamente rivestiti da una tela in cotone 100%.

GUANCIALE

Guanciale 100% piuma naturale lavata, depolverizzata e sterilizzata.

STRUCTURE

Laminated wood structure padded with polyurethane foam of differing densities and covered in 10 mm thick bonded resin.

FRAME

Fixed versions have a plywood frame beneath the seat cushions.

SEAT

The polyurethane padding used in the seat cushions is a minimum 30 HR density covered in a layer of Dacron with central spring insert.

SEAT - bed version

Polyurethane padding seat cushions with minimum 30 HR density covered in a layer of Dacron.

BACK

Back cushions have a 100% natural feather filling arranged in separate horizontal chambers supported with a polyurethane insert and covered entirely in a 100% cotton fabric. The dust-free feather filling has been cleaned and sterilised.

PILLOW

100% natural feather pillow; the dust-free feather filling has been cleaned and sterilised.

DIVANO / SOFA*

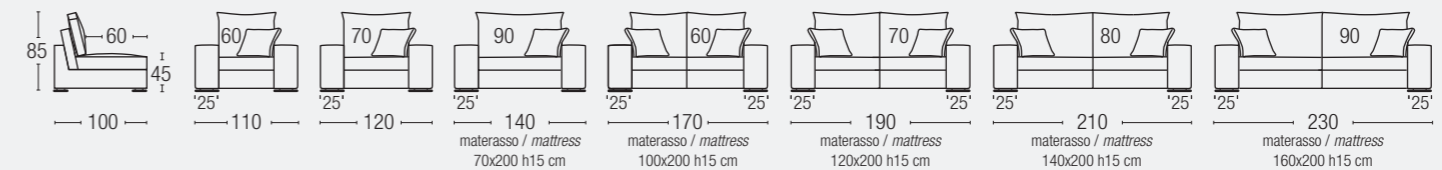

TERMINALE / ARMREST UNIT*

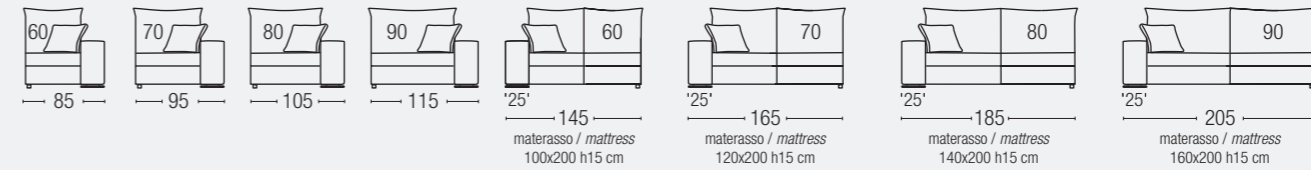

ANGOLO / CORNER

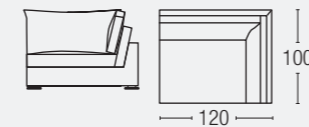

ANGOLARE CON POUF / CORNER WITH POUF



POUF

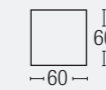

PIEDINI / FEET

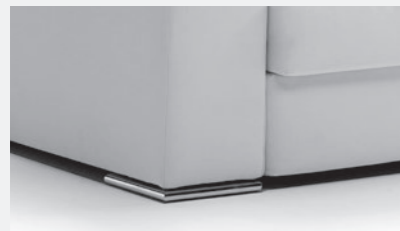

ANGOLARE

Cromato lucido / Polished chrome
h. 4 cm

*

Profondità divano con rete aperta cm. 217 / Sofas depth with open bed cm 217
Guanciali di serie 50x50 cm / Standard pillows 50x50 cm



AIRON

Pagina 184

Design:
Studio Archimeta

S O F A - B E D



STRUTTURA

Struttura in legno e multistrato imbottita in poliuretano a quote differenziate e rivestita in resinato accoppiato dello spessore di 10 mm.

TELAIO

Telaio sotto i cuscini di seduta in multistrato per le versioni fisse.

SEDUTA

Cuscini di seduta 100% in piuma naturale depolverizzata, lavata e sterilizzata a camere separate orizzontalmente e supportati da un inserto in poliuretano.

SCHIENALE

Cuscini schienale 100% in piuma naturale depolverizzata, lavata e sterilizzata, a camere separate orizzontalmente, con inserto in poliuretano interamente rivestiti da una tela in cotone 100%.

GUANCIALE

Guanciali 100% piuma naturale, lavata, depolverizzata e sterilizzata.

RETE - Versione letto

Rete a maglia elettrosaldada con materasso a molle altezza 15 cm

STRUCTURE

Laminated wood structure padded with polyurethane foam of differing densities and covered in 10 mm thick bonded resin.

FRAME

Fixed versions have a plywood frame beneath the seat cushions.

SEAT

Seat cushions have a 100% natural feather filling arranged in separate horizontal chambers supported with a polyurethane insert; the dust-free feather filling has been cleaned and sterilised.

BACK

Back cushions have a 100% natural feather filling arranged in separate horizontal chambers supported with a polyurethane insert and covered entirely in a 100% cotton fabric. The dust-free feather filling has been cleaned and sterilised.

PILLOW

100% natural feather pillow; the dust-free feather filling has been cleaned and sterilised.

BED BASE - Bed version

The net is knitted electrowelded with spring mattress height 15 cm

DIVANO / SOFA*

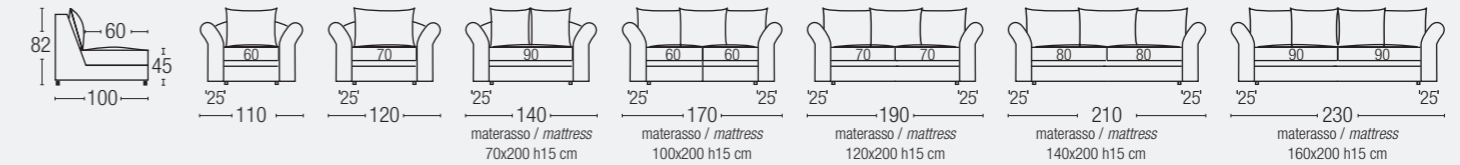

POUF

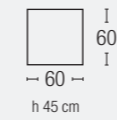



ALEX

Design:
Arch. Danilo Bonfanti

Pagina 084

STRUTTURA

Struttura in legno e multistrato imbottita in poliuretano a quote differenziate e rivestita in resinato accoppiato dello spessore di 10 mm.

TELAIO

Telaio sotto i cuscini di seduta in multistrato per le versioni fisse.

SEDUTA

Cuscini di seduta in poliuretano densità minima 30 HR rivestiti da una falda Dacron con inserto centrale a molle.

SCHIENALE

Cuscini schienale 100% in piuma naturale depolverizzata, lavata e sterilizzata, a camere separate orizzontalmente, con inserto in poliuretano interamente rivestiti da una tela in cotone 100%.

GUANCIALE

Guanciali 100% piuma naturale, lavata, depolverizzata e sterilizzata.

STRUCTURE

Laminated wood structure padded with polyurethane foam of differing densities and covered in 10 mm thick bonded resin.

FRAME

Fixed versions have a plywood frame beneath the seat cushions.

SEAT

The polyurethane padding used in the seat cushions is a minimum 30 HR density covered in a layer of Dacron with central spring insert.

BACK

Back cushions have a 100% natural feather filling arranged in separate horizontal chambers supported with a polyurethane insert and covered entirely in a 100% cotton fabric. The dust-free feather filling has been cleaned and sterilised.

PILLOW

100% natural feather pillow; the dust-free feather filling has been cleaned and sterilised.

DIVANO / SOFA

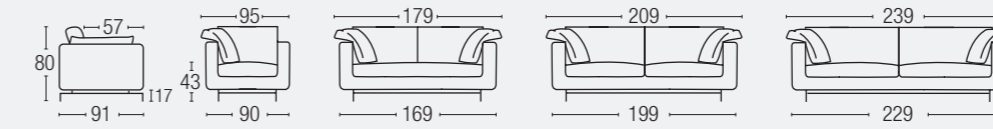

POUF

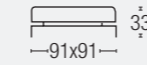

PIEDINI / FEET



PONTE

Cromato / Chrome



ALTEA

Pagina 150

Design:
Arch. Danilo Bonfanti

STRUTTURA

Struttura in legno e multistrato imbottita in poliuretano a quote differenziate e rivestita in resinato accoppiato dello spessore di 10 mm

MOLLEGGIO

Molleggio della seduta in nastri elastici intrecciati ad alta densità

SEDUTA

Cuscini di seduta 100% in piuma naturale depolverizzata, lavata e sterilizzata a camere separate orizzontalmente e supportati da un inserto in poliuretano.

SCHIENALE

Cuscini schienale 50% in piuma naturale depolverizzata, lavata e sterilizzata - 50% poliuretano, a camere separate orizzontalmente interamente rivestiti da una tela in cotone 100%.

GUANCIALE

Guanciali 100% piuma naturale, lavata, depolverizzata e sterilizzata.

RETE - Versione letto

Rete a doghe di faggio con materasso altezza 8 cm in poliuretano densità 30 HR.

STRUCTURE

Laminated wood structure padded with polyurethane foam of differing densities and covered in 10 mm thick bonded resin.

SUSPENSION

The seat suspension system uses high density intertwined elastic ribbons.

SEAT

Seat cushions have a 100% natural feather filling arranged in separate horizontal chambers supported with a polyurethane insert; the dust-free feather filling has been cleaned and sterilised.

BACK

Back cushions have a 50% natural feather - 50% polyurethane filling arranged in separate horizontal chambers supported with a polyurethane insert and covered entirely in a 100% cotton fabric. The dust-free feather filling has been cleaned and sterilised.

PILLOW

100% natural feather pillow; the dust-free feather filling has been cleaned and sterilised.

BED BASE - Bed version

Beech slatted base with mattress height 8 cm in 30 HR density polyurethane.

DIVANO / SOFA*

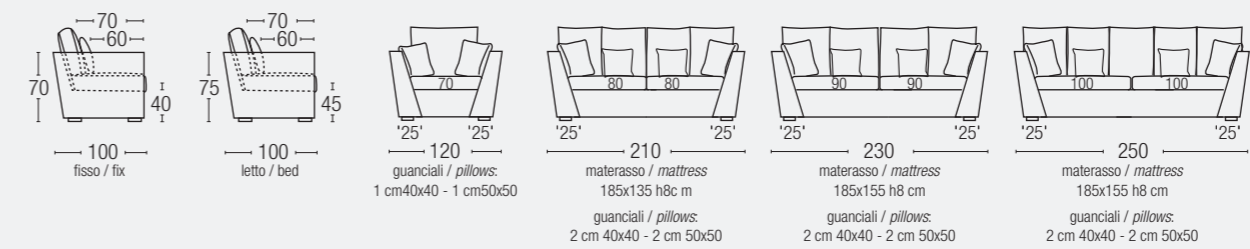

TERMINALE / ARMREST UNIT*

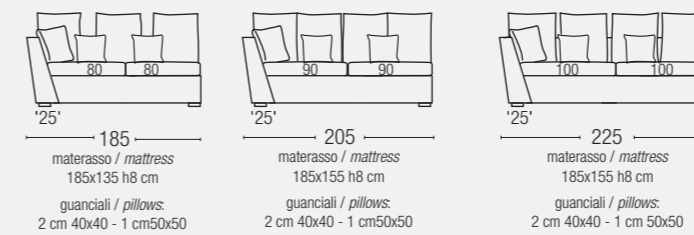

ANGOLO / CORNER

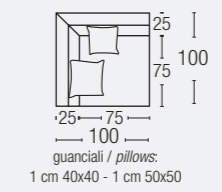

TERMINALI CURVI / CURVED ARMREST UNIT

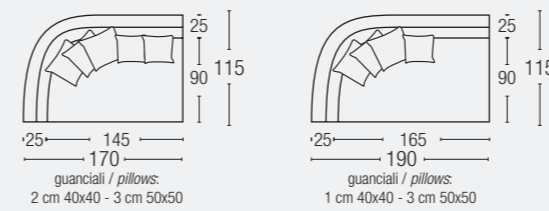

PANCA / BENCH

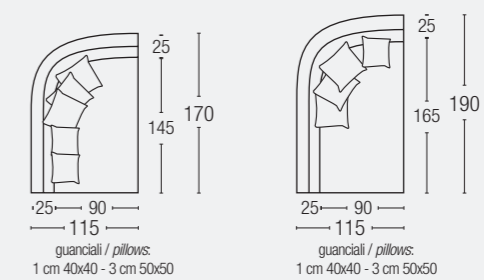

PIEDINI / FEET

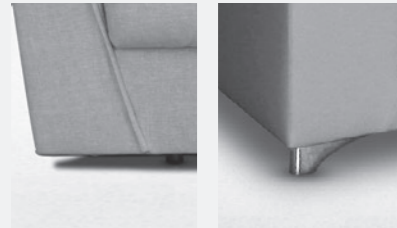

Wengè / Wengè
h. 3 cm

NAVE
Cromato / Chrome
h. 8 cm
SOLO VERSIONE LETTO
ONLY BED VERSION



AVATAR

Pagina 100

Design:
Studio Archimeta

STRUTTURA

Struttura in legno e multistrato imbottita in poliuretano a quote differenziate e rivestita in resinato accoppiato dello spessore di 10 mm.

TELAIO

Telaio sotto i cuscini di seduta in multistrato per le versioni fisse.

SEDUTA

Cuscini di seduta in poliuretano densità minima 30 HR rivestiti da una falda Dacron con inserto centrale a molle.

SCHIENALE

Cuscini schienale 50% in piuma naturale depolverizzata, lavata e sterilizzata - 50% poliuretano, a camere separate orizzontalmente interamente rivestiti da una tela in cotone 100%.

GUANCIALE

Guanciale 100% piuma naturale lavata, depolverizzata e sterilizzata.

STRUCTURE

Laminated wood structure padded with polyurethane foam of differing densities and covered in 10 mm thick bonded resin.

FRAME

Fixed versions have a plywood frame beneath the seat cushions.

SEAT

The polyurethane padding used in the seat cushions is a minimum 30 HR density covered in a layer of Dacron with central spring insert.

BACK

Back cushions have a 50% natural feather - 50% polyurethane filling arranged in separate horizontal chambers supported with a polyurethane insert and covered entirely in a 100% cotton fabric.

PILLOW

100% natural feather pillow; the dust-free feather filling has been cleaned and sterilised.

DIVANO / SOFA*

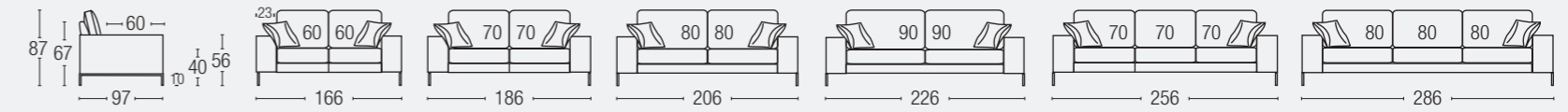

TERMINALE / ARMREST UNIT*

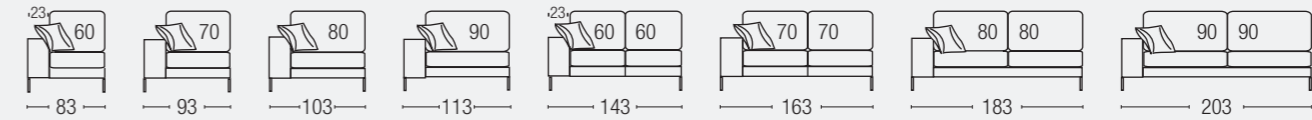

BRACCIOLO / ARMREST*

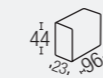

POUF

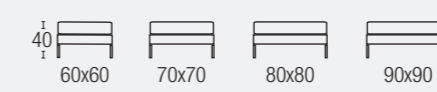

PANCA / BENCH



CHAISE LONGUE

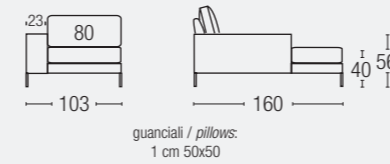

PENISOLA / PENINSULA

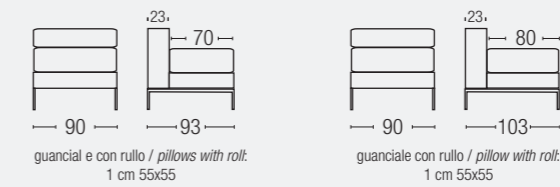

ANGOLO / CORNER

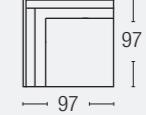

PIEDINI / FEET

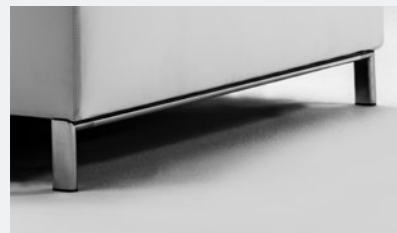

PONTE

Cromato lucido / Polished chrome
h. 14 cm



BELLO

Pagina 040

STRUTTURA

Struttura in legno e multistrato imbottita in poliuretano a quote differenziate e rivestita in resinato accoppiato dello spessore di 10 mm.

MOLLEGGIO

Molleggio della seduta in nastri elastici intrecciati ad alta densità.

SEDUTA

Cuscini di seduta in poliuretano densità minima 30 HR rivestiti da una falda Dacron.

SCHIENALE

Cuscini schienale 40% poliuretano - 40% cin fill ball (fibra poliestere siliconata cava a pallino) - 20% memory foam, a camere separate orizzontalmente interamente rivestiti da una tela in cotone 100%.

GUANCIALE

Guanciale 100% piuma naturale lavata, depolverizzata e sterilizzata.

STRUCTURE

Laminated wood structure padded with polyurethane foam of differing densities and covered in 10 mm thick bonded resin.

SUSPENSION

The seat suspension system uses high density intertwined elastic ribbons.

SEAT

Polyurethane padding seat cushions with minimum 30 HR density covered in a layer of Dacron.

BACK

Back cushions have a 40% polyurethane - 40% cin fill ball (siliconised polyester ball fibre) - 20% memory foam filling arranged in separate horizontal chambers covered entirely in a 100% cotton fabric. The dust-free feather filling has been cleaned and sterilised.

PILLOW

100% natural feather pillow; the dust-free feather filling has been cleaned and sterilised.

PIEDINI / FEET



PONTE NICK

Brunito / Burnished
Cromato lucido / Polished chrome
Satinato / Satin
h. 15 cm
A richiesta / On request:
- Montaggio a 45°/45° mounting
- RAL verniciato opaco / Matt RAL color



SPILLO NICK

Brunito / Burnished
Cromato lucido / Polished chrome
Satinato / Satin
h. 15 cm
A richiesta / On request:
- RAL verniciato opaco / Matt RAL color



SCOMPARSA

Legno / Wood
h. 4 cm

TAVOLINI / SMALL TABLE



TONDO

ø 40 cm h. 55 cm



QUADRATO

40x40 cm wh. 55 cm

DIVANO / SOFA

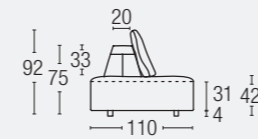
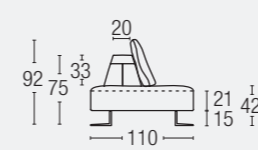

DIVANO / SOFA

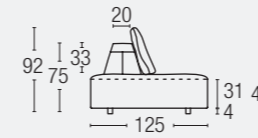
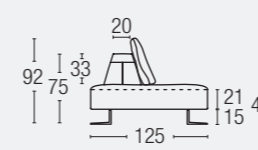

SCHIENALE / BACK

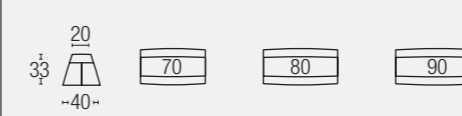

SEDUTA / SEAT

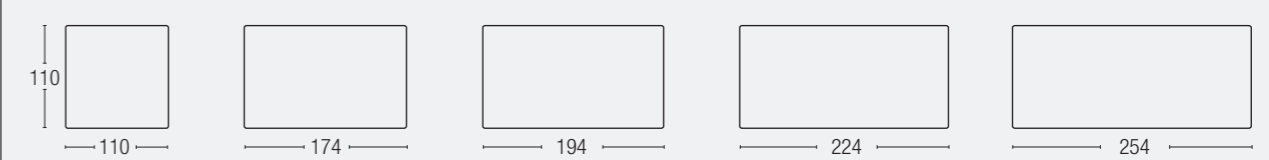

SCHIENALE / BACK

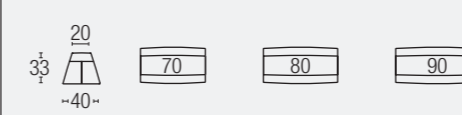

SEDUTA / SEAT

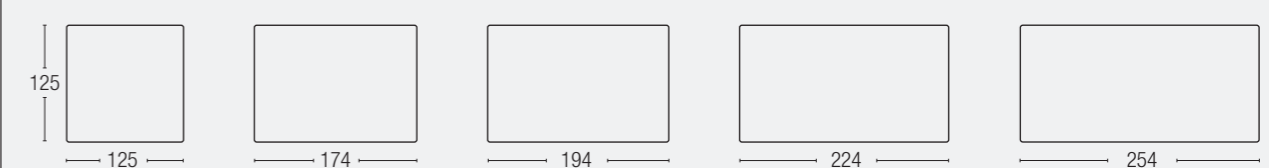

ELEMENTI SPECIALI / SPECIAL ELEMENTS

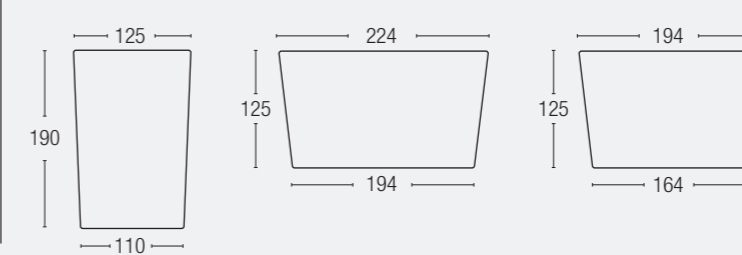

ESEMPI DI CONFIGURAZIONI CONFIGURATIONS EXAMPLES

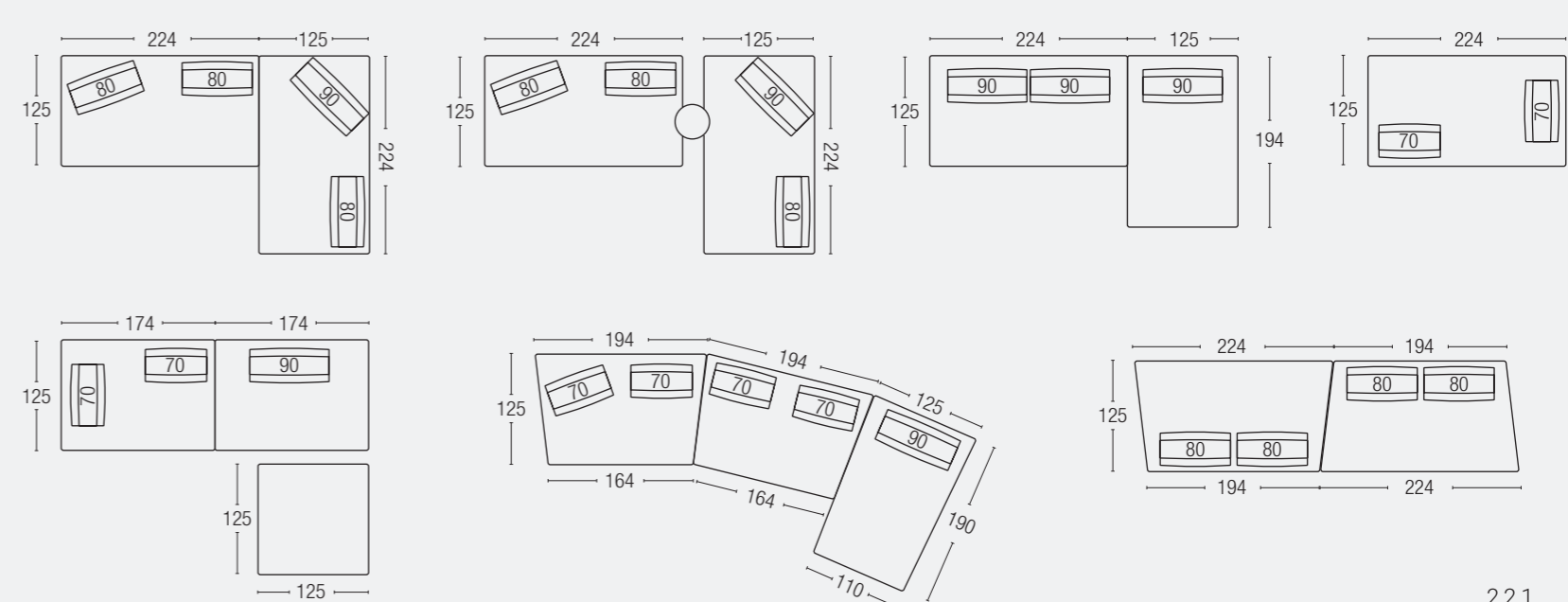



BOSTON

Pagina 120

Design:
Arch. Danilo Bonfanti

STRUTTURA

Struttura in legno e multistrato imbottita in poliuretano a quote differenziate e rivestita in resinato accoppiato dello spessore di 10 mm.

TELAIO

Telaio sotto i cuscini di seduta in multistrato per le versioni fisse.

SEDUTA

Cuscini di seduta in poliuretano densità minima 30 HR rivestiti da una falda Dacron con inserto centrale a molle.

SCHIENALE

Cuscini schienale 100% in piuma naturale depolverizzata, lavata e sterilizzata, a camere separate orizzontalmente, con inserto in poliuretano interamente rivestiti da una tela in cotone 100%.

GUANCIALE

Guanciale 100% piuma naturale lavata, depolverizzata e sterilizzata.

STRUCTURE

Laminated wood structure padded with polyurethane foam of differing densities and covered in 10 mm thick bonded resin.

FRAME

Fixed versions have a plywood frame beneath the seat cushions.

SEAT

The polyurethane padding used in the seat cushions is a minimum 30 HR density covered in a layer of Dacron with central spring insert.

BACK

Back cushions have a 100% natural feather filling arranged in separate horizontal chambers supported with a polyurethane insert and covered entirely in a 100% cotton fabric. The dust-free feather filling has been cleaned and sterilised.

PILLOW

100% natural feather pillow; the dust-free feather filling has been cleaned and sterilised.

DIVANO / SOFA

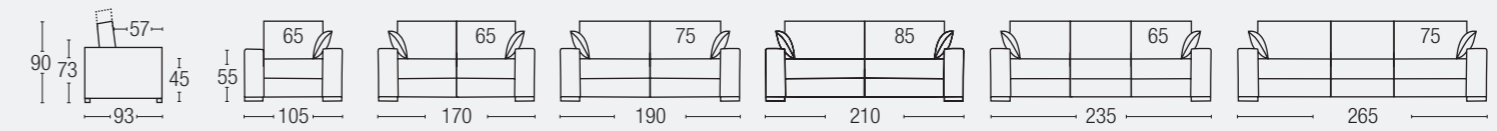

POUF

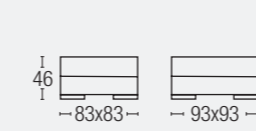

BRACCIOLO / ARMREST*



TERMINALE / ARMREST UNIT

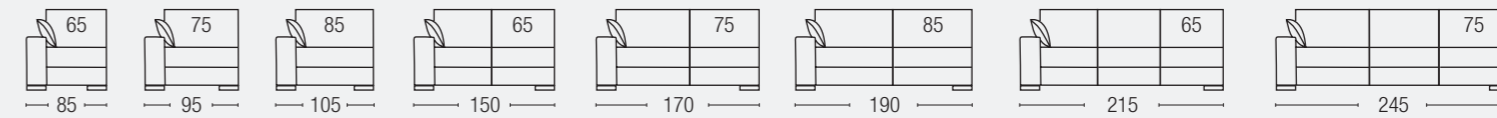

ANGOLO / CORNER

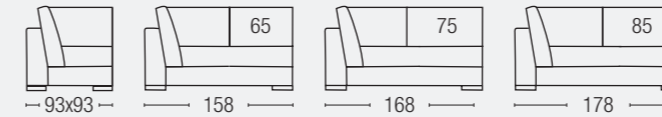

PENISOLA / PENINSULA

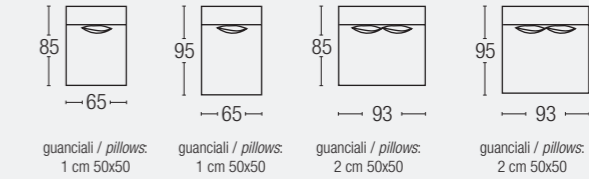

CHAISE LONGUE

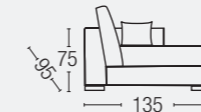

PIEDINI / FEET



LISTELLO

Wengè / Wengè

Legno rivestito in lamina metallo satinato opaco

Wood covered in matt satined metal foil

h. 4 cm



BRAD

Pagina 134

Design:
Arch. Danilo Bonfanti

STRUTTURA

Struttura in legno e multistrato imbottita in poliuretano a quote differenziate e rivestita in resinato accoppiato dello spessore di 10 mm.

MOLLEGGIO

Molleggio della seduta in nastri elastici intrecciati ad alta densità.

SEDUTA

Cuscini di seduta 100% in piuma naturale depolverizzata, lavata e sterilizzata a camere separate orizzontalmente e supportati da un inserto in poliuretano.

SCHIENALE

Cuscini schienale 50% in piuma naturale depolverizzata, lavata e sterilizzata - 50% poliuretano, a camere separate orizzontalmente interamente rivestiti da una tela in cotone 100%.

GUANCIALE

Guanciaie 100% piuma naturale lavata, depolverizzata e sterilizzata.

STRUCTURE

Laminated wood structure padded with polyurethane foam of differing densities and covered in 10 mm thick bonded resin.

SUSPENSION

The seat suspension system uses high density intertwined elastic ribbons.

SEAT

Seat cushions have a 100% natural feather filling arranged in separate horizontal chambers supported with a polyurethane insert; the dust-free feather filling has been cleaned and sterilised.

BACKS

Back cushions have a 50% natural feather - 50% polyurethane filling arranged in separate horizontal chambers supported with a polyurethane insert and covered entirely in a 100% cotton fabric. The dust-free feather filling has been cleaned and sterilised.

PILLOW

100% natural feather pillow; the dust-free feather filling has been cleaned and sterilised.

DIVANO / SOFA

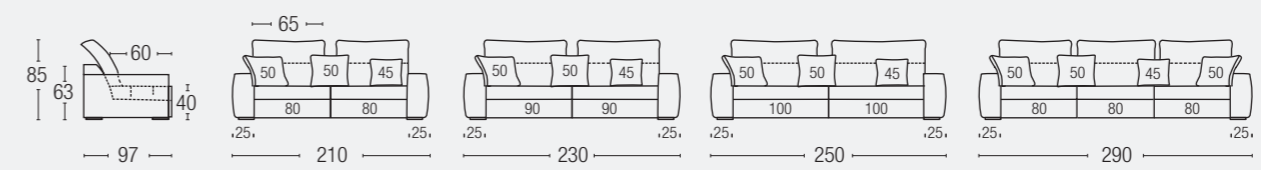

TERMINALE / ARMREST UNIT

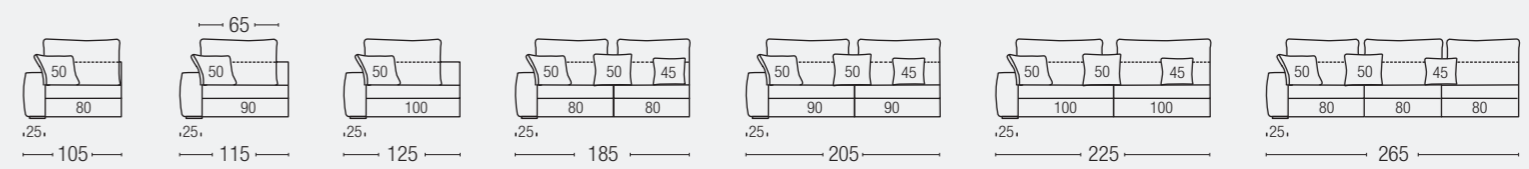

ANGOLARE CON POUF / CORNER WITH POUF

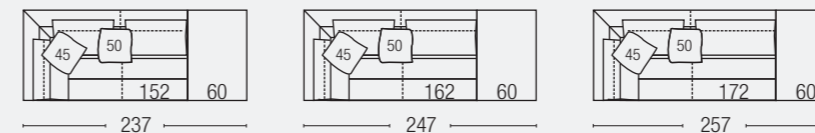

POUF

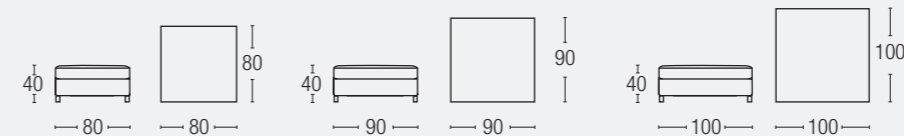

ANGOLO / CORNER

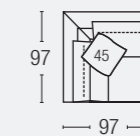

PANCA / BENCH

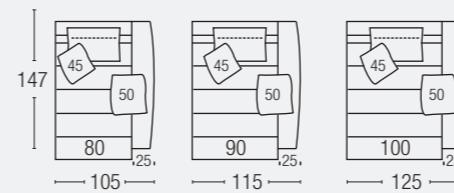

BRACCIOLO / ARMREST



guanciali / pillows:
1 cm 50x50

PIEDINI / FEET



RONDELLA

Finitura noce scuro / Dark walnut finish
h. 3 cm

CUSCINI DI SEDUTA / SEAT CUSHIONS

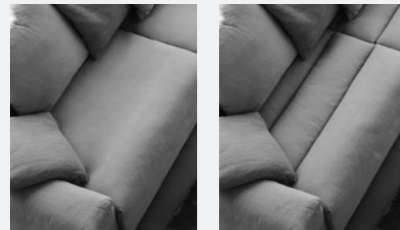

Senza cuciture
Stitchingless

Con cuciture
With stitchings



BRAVO

Pagina 006

Design:
Arch. Danilo Bonfanti

STRUTTURA

Struttura in legno e multistrato imbottita in poliuretano a quote differenziate e rivestita in resinato accoppiato dello spessore di 10 mm.

MOLLEGGIO

Molleggio della seduta in nastri elastici intrecciati ad alta densità.

SEDUTA

Cuscini di seduta in poliuretano densità minima 30 HR rivestiti da una falda Dacron.

SCHIENALE

Cuscini schienale 40% poliuretano - 40% cin fill ball (fibra poliestere siliconata cava a pallino) - 20% memory foam, a camere separate orizzontalmente interamente rivestiti da una tela in cotone 100%.

GUANCIALE

Guanciaie 100% piuma naturale lavata, depolverizzata e sterilizzata.

STRUCTURE

Laminated wood structure padded with polyurethane foam of differing densities and covered in 10 mm thick bonded resin.

SUSPENSION

The seat suspension system uses high density intertwined elastic ribbons.

SEAT

Polyurethane padding seat cushions with minimum 30 HR density covered in a layer of Dacron.

BACK

Back cushions have a 40% polyurethane - 40% cin fill ball (siliconised polyester ball fibre) - 20% memory foam filling arranged in separate horizontal chambers covered entirely in a 100% cotton fabric. The dust-free feather filling has been cleaned and sterilised.

PILLOW

100% natural feather pillow; the dust-free feather filling has been cleaned and sterilised.

DIVANO / SOFA

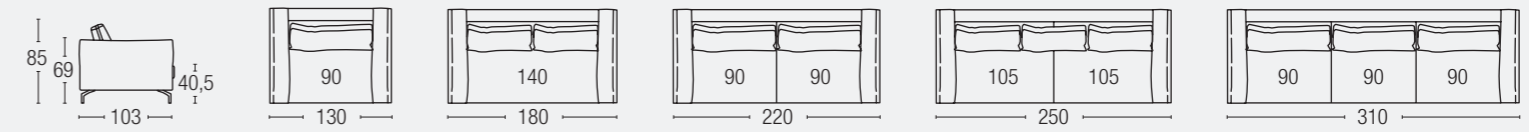

TERMINALE / ARMREST UNIT

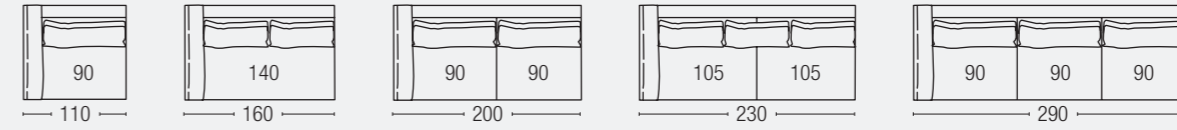

CHAISE LOUNGUE

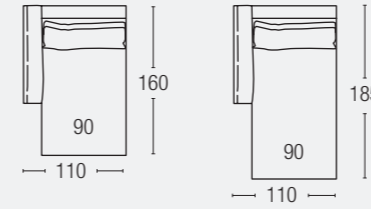

ANGOLO / CORNER

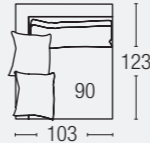

TERMINALE CON POUF / ARMREST UNIT WITH POUF

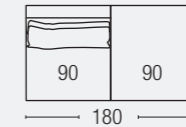

POUF

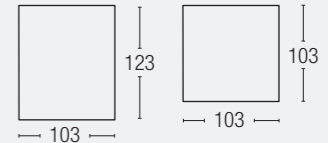

PIEDINI / FEET

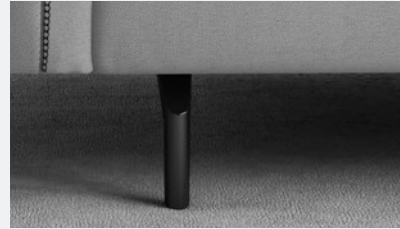

SMERALDO

Alluminio cromato / Chromed aluminum
Brunito / Burnished



PONTE NICK

Brunito / Burnished
Cromato lucido / Polished chrome
Satinato / Satin

BRACCIOLI / ARMS



Bracciolo regolabile
Adjustable armrest

ESEMPI DI CONFIGURAZIONI CONFIGURATIONS EXAMPLES

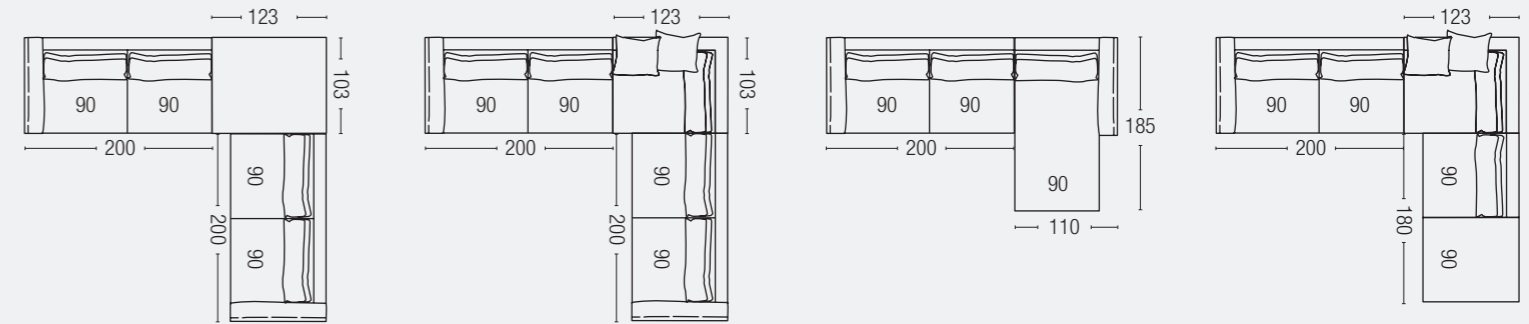



CHARLIE

Pagina 126

Design:
Arch. Danilo Bonfanti

STRUTTURA

Struttura in legno e multistrato imbottita in poliuretano a quote differenziate e rivestita in resinato accoppiato dello spessore di 10 mm.

MOLLEGGIO

Molleggio della seduta in nastri elastici intrecciati ad alta densità.

SEDUTA

Cuscini di seduta in poliuretano densità minima 30 HR rivestiti da una falda Dacron.

SCHIENALE

Cuscini schienale 50% in piuma naturale depolverizzata, lavata e sterilizzata - 50% poliuretano, a camere separate orizzontalmente interamente rivestiti da una tela in cotone 100%.

GUANCIALE

Guanciali 50% piuma naturale depolverizzata, lavata e sterilizzata - 50% poliuretano.

STRUCTURE

Laminated wood structure padded with polyurethane foam of differing densities and covered in 10 mm thick bonded resin.

SUSPENSION

The seat suspension system uses high density intertwined elastic ribbons.

SEAT

Polyurethane padding seat cushions with minimum 30 HR density covered in a layer of Dacron.

BACKS

Back cushions have a 50% natural feather - 50% polyurethane filling arranged in separate horizontal chambers supported with a polyurethane insert and covered entirely in a 100% cotton fabric. The dust-free feather filling has been cleaned and sterilised.

PILLOW

Pillow 50% natural feather - 50% polyurethane; the dust-free feather filling has been cleaned and sterilised.

DIVANO / SOFA*

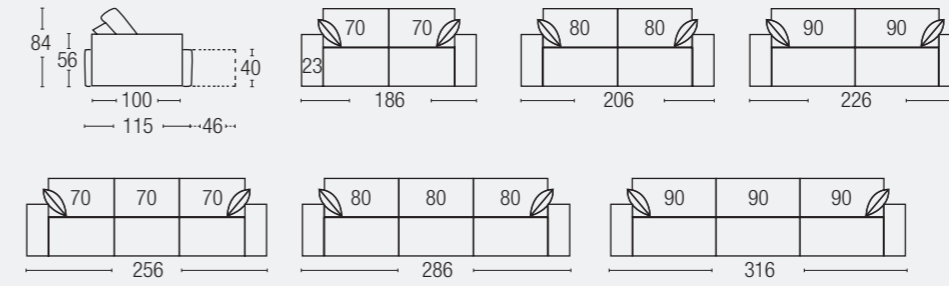

DIVANO CON CHAISE LONGUE / SOFA WITH CHAISE LONGUE*

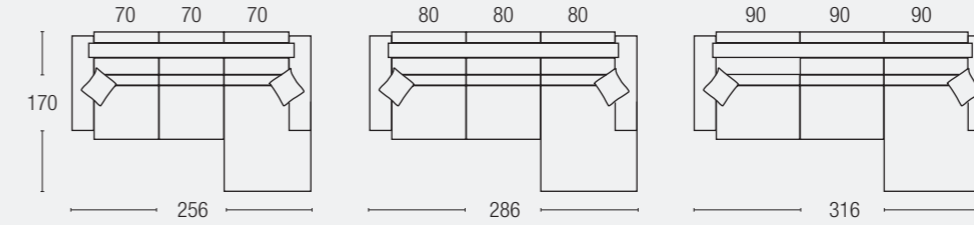

PIEDINI / FEET



LISTELLO

Legno rivestito in lamina di metallo satinato opaco
Wood covered in matt satined metal sheet
h. 3,5 cm



DIECI

Pagina 196

Design:
Studio Archimeta

S O F A - B E D



STRUTTURA

Struttura in legno e multistrato imbottita in poliuretano a quote differenziate e rivestita in resinato accoppiato dello spessore di 10 mm.

TELAIO

Telaio sotto i cuscini di seduta in multistrato per le versioni fisse.

SEDUTA

Cuscini di seduta in poliuretano densità minima 30 HR rivestiti da una falda Dacron.

SCHIENALE

Cuscini schienale 50% in piuma naturale depolverizzata, lavata e sterilizzata - 50% poliuretano, a camere separate orizzontalmente interamente rivestiti da una tela in cotone 100%.

GUANCIALE

Guanciale 100% piuma naturale lavata, depolverizzata e sterilizzata.

RETE - Versione letto

Rete a maglia elettrosaldata con materasso a molle altezza 15 cm

STRUCTURE

Laminated wood structure padded with polyurethane foam of differing densities and covered in 10 mm thick bonded resin.

FRAME

Fixed versions have a plywood frame beneath the seat cushions.

SEAT

Polyurethane padding seat cushions with minimum 30 HR density covered in a layer of Dacron.

BACK

Back cushions have a 50% natural feather - 50% polyurethane filling arranged in separate horizontal chambers supported with a polyurethane insert and covered entirely in a 100% cotton fabric. The dust-free feather filling has been cleaned and sterilised.

PILLOW

100% natural feather pillow; the dust-free feather filling has been cleaned and sterilised.

BED BASE - Bed version

The net is knitted electrowelded with spring mattress height 15 cm

DIVANO / SOFA*

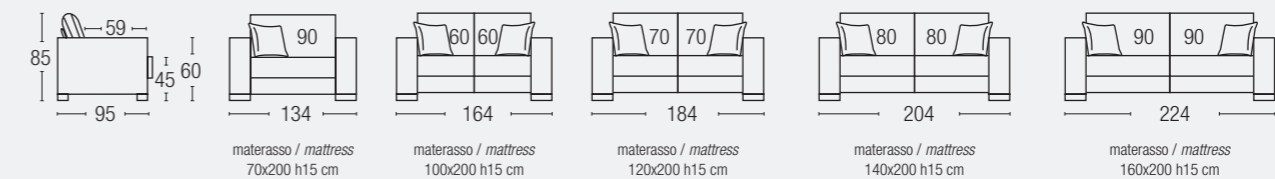

TERMINALE / ARMREST UNIT*

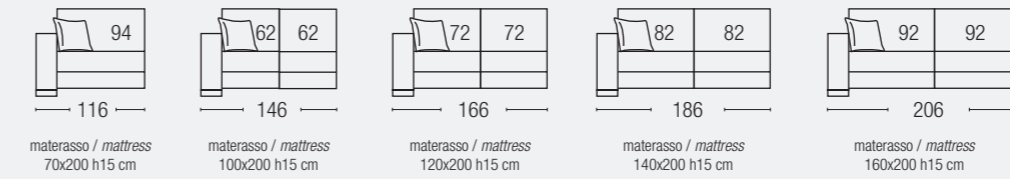

CHAISE LONGUE*

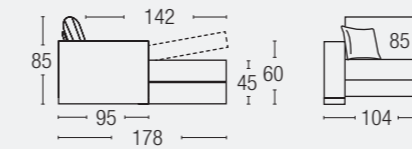

PIEDINI / FEET



Faggio colore Wengè / Beech Wengè color
h. 5 cm

*

Profondità divano con rete aperta cm. 217 / Sofas depth with open bed cm. 217

Guanciali di serie 45x45cm / Standard pillows 45x45cm



EGO

Pagina 174

Design:
Arch. Danilo Bonfanti

S O F A - B E D



STRUTTURA

Struttura in legno e multistrato imbottita in poliuretano a quote differenziate e rivestita in resinato accoppiato dello spessore di 10 mm.

TELAIO

Telaio sotto i cuscini di seduta in multistrato per le versioni fisse.

SEDUTA

Cuscini di seduta 100% in piuma naturale depolverizzata, lavata e sterilizzata a camere separate orizzontalmente e supportati da un inserto in poliuretano.

GUANCIALE

Guanciale 100% piuma naturale lavata, depolverizzata e sterilizzata.

STRUCTURE

Laminated wood structure padded with polyurethane foam of differing densities and covered in 10 mm thick bonded resin.

FRAME

Fixed versions have a plywood frame beneath the seat cushions.

SEAT

Seat cushions have a 100% natural feather filling arranged in separate horizontal chambers supported with a polyurethane insert; the dust-free feather filling has been cleaned and sterilised.

PILLOW

100% natural feather pillow; the dust-free feather filling has been cleaned and sterilised.

DIVANO / SOFA*

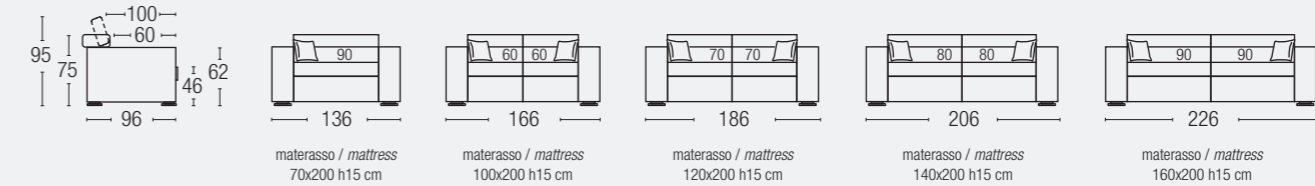

TERMINALE / ARMREST UNIT*

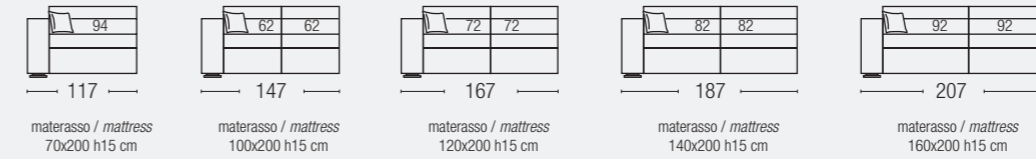

PANCA / BENCH

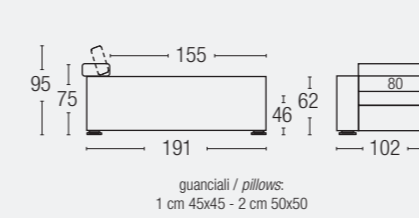

CHAISE LONGUE

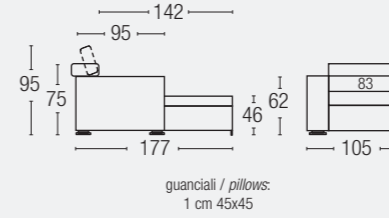

ANGOLO / CORNER

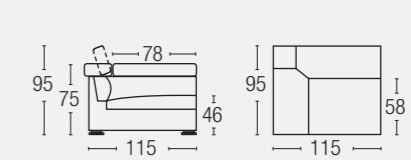

PIEDINI / FEET



Legno rivestito metallo cromato lucido
Wood covered with polished chrome metal
h.5 cm

POGGIATESTA / HEADREST



Poggiatesta regolabile in 6 posizioni
Headrest adjustable in 6 positions

*

Profondità divano con rete aperta cm. 217 / Sofas depth with open bed cm. 217
Guanciali di serie 45x45cm / Standard pillows 45x45cm



FREEDOM

Pagina 028

Design:
Arch. Danilo Bonfanti

STRUTTURA

Struttura in legno e multistrato imbottita in poliuretano a quote differenziate e rivestita in resinato accoppiato dello spessore di 10 mm.

MOLLEGGIO

Molleggio della seduta in nastri elastici intrecciati ad alta densità.

SEDUTA

Cuscini di seduta 100% in piuma naturale depolverizzata, lavata e sterilizzata a camere separate orizzontalmente e supportati da un inserto in poliuretano.

SCHIENALE

Cuscini schienale 100% in piuma naturale depolverizzata, lavata e sterilizzata, a camere separate orizzontalmente, con inserto in poliuretano interamente rivestiti da una tela in cotone 100%.

GUANCIALE

Guanciale 100% piuma naturale lavata, depolverizzata e sterilizzata.

STRUCTURE

Laminated wood structure padded with polyurethane foam of differing densities and covered in 10 mm thick bonded resin.

SUSPENSION

The seat suspension system uses high density intertwined elastic ribbons.

SEAT

Seat cushions have a 100% natural feather filling arranged in separate horizontal chambers supported with a polyurethane insert; the dust-free feather filling has been cleaned and sterilised.

BACK

Back cushions have a 100% natural feather filling arranged in separate horizontal chambers supported with a polyurethane insert and covered entirely in a 100% cotton fabric. The dust-free feather filling has been cleaned and sterilised.

PILLOW

100% natural feather pillow; the dust-free feather filling has been cleaned and sterilised.

DIVANO / SOFA*

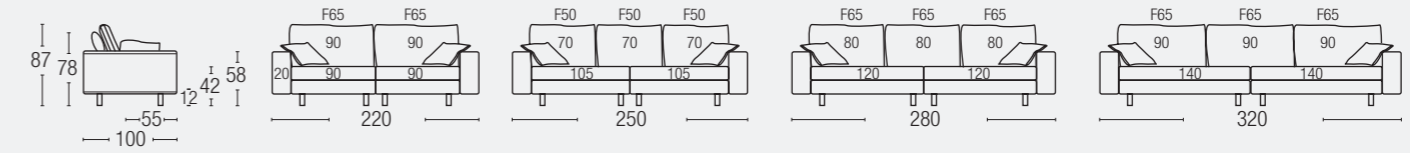

PENISOLA E ELEMENTO CENTRALE / PENINSULA AND CENTRAL ELEMENT

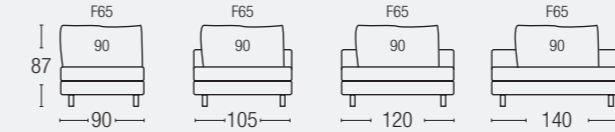

TERMINALE / ARMREST UNIT*

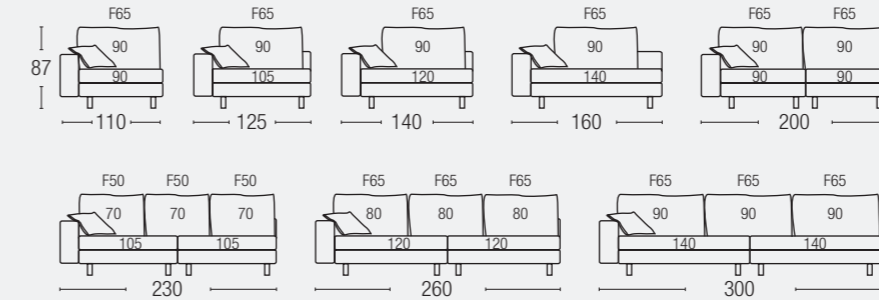

CHAISE LONGUE

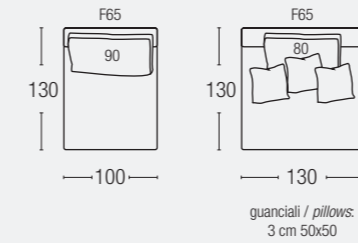

guanciali / pillows:
3 cm 50x50

ESEMPI DI CONFIGURAZIONI CONFIGURATIONS EXAMPLES

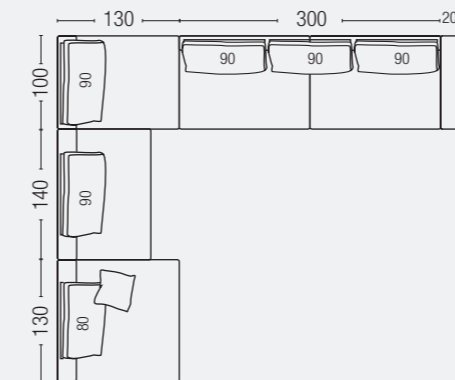

PIEDINI / FEET



Bronzato / Bronzed
h. 12,5 cm



HOLÀ

Pagina 188

Design:
Arch. Danilo Bonfanti

S O F A - B E D



DIVANO / SOFA*

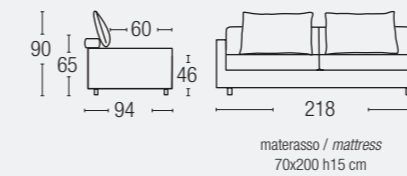

STRUTTURA

Struttura in legno e multistrato imbottita in poliuretano a quote differenziate e rivestita in resinato accoppiato dello spessore di 10 mm.

RETE - versione letto

Rete a maglia elettrosaldata con materasso in espanso densità 30 HR altezza 15 cm.

STRUCTURE

Laminated wood structure padded with polyurethane foam of differing densities and covered in 10 mm thick bonded resin.

BED BASE - Bed version

The net is knitted electrowelded with polyurethane mattress height 15 cm in 30 HR density.

SEDUTA

Cuscini di seduta in poliuretano densità minima 30 HR rivestiti da una falda Dacron.

SEAT

Polyurethane padding seat cushions with minimum 30 HR density covered in a layer of Dacron.

SCHIENALE

Cuscini schienale 100% in piuma naturale depolverizzata, lavata e sterilizzata, a camere separate orizzontalmente, con inserto in poliuretano interamente rivestiti da una tela in cotone 100%.

BACK

Back cushions have a 100% natural feather filling arranged in separate horizontal chambers supported with a polyurethane insert and covered entirely in a 100% cotton fabric. The dust-free feather filling has been cleaned and sterilised.

PIEDINI / FEET



Cromato / Chromed
Noce / Walnut
h. 8 cm



JOY

Pagina 078

Design:
Arch. Danilo Bonfanti

STRUTTURA

Struttura in legno e multistrato imbottita in poliuretano a quote differenziate e rivestita in resinato accoppiato dello spessore di 10 mm.

MOLLEGGIO

Molleggio della seduta in nastri elastici intrecciati ad alta densità.

SEDUTA

Cuscini di seduta in poliuretano densità minima 30 HR rivestiti da una falda Dacron.

SCHIENALE

Cuscini schienale 100% in piuma naturale depolverizzata, lavata e sterilizzata, a camere separate orizzontalmente, con inserto in poliuretano interamente rivestiti da una tela in cotone 100%.

GUANCIALE

Guanciale 100% piuma naturale lavata, depolverizzata e sterilizzata.

STRUCTURE

Laminated wood structure padded with polyurethane foam of differing densities and covered in 10 mm thick bonded resin.

SUSPENSION

The seat suspension system uses high density intertwined elastic ribbons.

SEAT

Polyurethane padding seat cushions with minimum 30 HR density covered in a layer of Dacron.

BACK

Back cushions have a 100% natural feather filling arranged in separate horizontal chambers supported with a polyurethane insert and covered entirely in a 100% cotton fabric. The dust-free feather filling has been cleaned and sterilised.

PILLOW

100% natural feather pillow; the dust-free feather filling has been cleaned and sterilised.

PIEDINI / FEET



A SCOMPARSA

Rotondo, legno colore wengè
Round, wengè colored wood
h. 3 cm

DIVANO / SOFA*

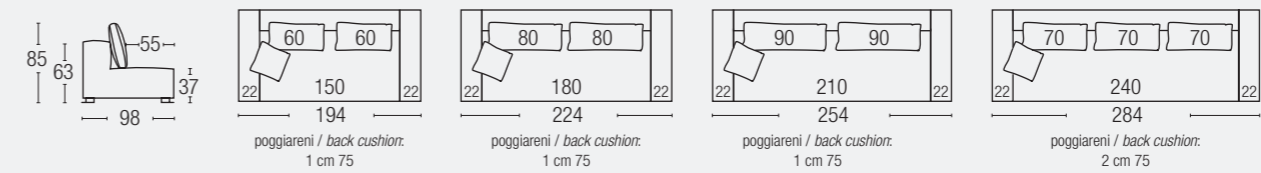

TERMINALE / ARMREST UNIT*

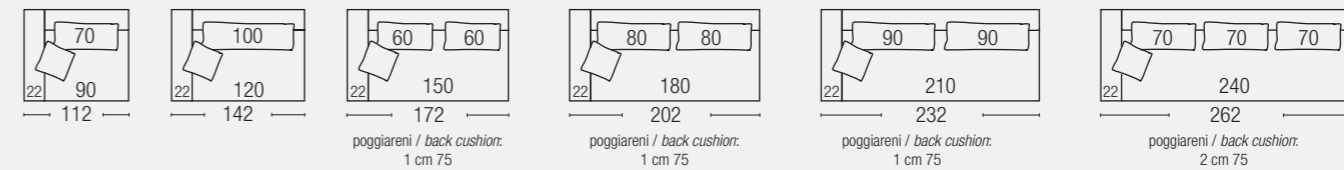

ELEMENTO CENTRALE / CENTRAL ELEMENT

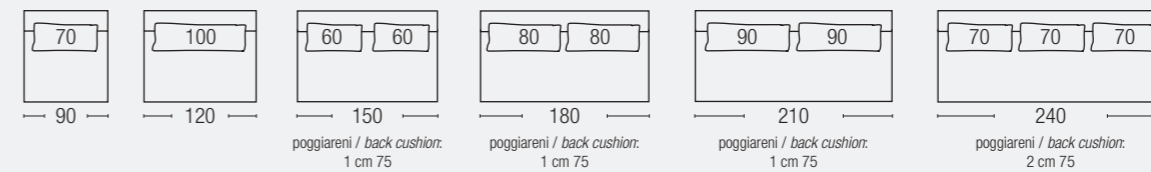

TERMINALE ANGOLARE CON POUF / CORNER ARMREST WITH POUF*

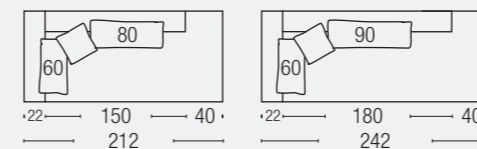

ELEMENTO CON POUF / ELEMENT WITH POUF

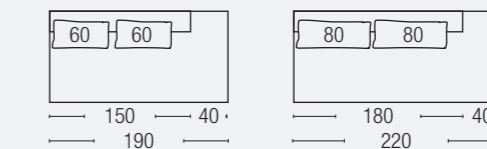

CHAISE LONGUE RELAX*

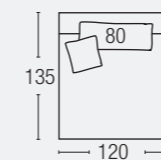

RELAX*

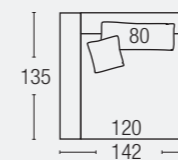

POUF

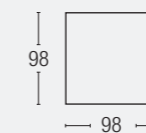

* Guanciali di serie 45x45 cm / Standard pillows 45x45 cm



LINK

Pagina 058

Design:
Arch. Danilo Bonfanti

STRUTTURA

Struttura in legno e multistrato imbottita in poliuretano a quote differenziate e rivestita in resinato accoppiato dello spessore di 10 mm.

MOLLEGGIO

Molleggio della seduta in nastri elastici intrecciati ad alta densità.

SEDUTA

Cuscini di seduta in poliuretano densità minima 30 HR rivestiti da una falda Dacron.

SCHIENALE

Cuscini schienale 40% poliuretano - 40% cin fill ball (fibra poliestere siliconata cava a pallino) - 20% memory foam, a camere separate orizzontalmente interamente rivestiti da una tela in cotone 100%.

GUANCIALE

Guanciale 100% piuma naturale lavata, depolverizzata e sterilizzata.

STRUCTURE

Laminated wood structure padded with polyurethane foam of differing densities and covered in 10 mm thick bonded resin.

SUSPENSION

The seat suspension system uses high density intertwined elastic ribbons.

SEAT

Polyurethane padding seat cushions with minimum 30 HR density covered in a layer of Dacron.

BACKS

Back cushions have a 40% polyurethane - 40% cin fill ball (siliconised polyester ball fibre) - 20% memory foam filling arranged in separate horizontal chambers covered entirely in a 100% cotton fabric. The dust-free feather filling has been cleaned and sterilised.

PILLOW

100% natural feather pillow; the dust-free feather filling has been cleaned and sterilised.

DIVANO / SOFA*

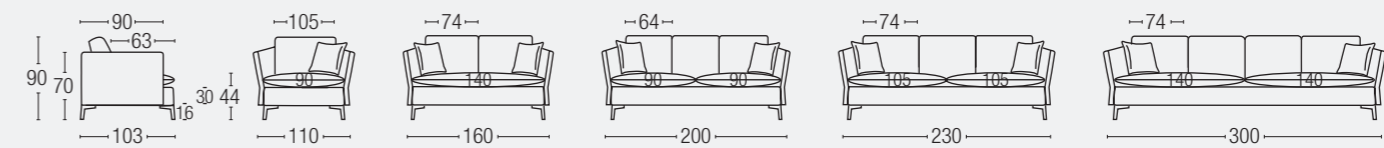

TERMINALE / ARMREST UNIT*

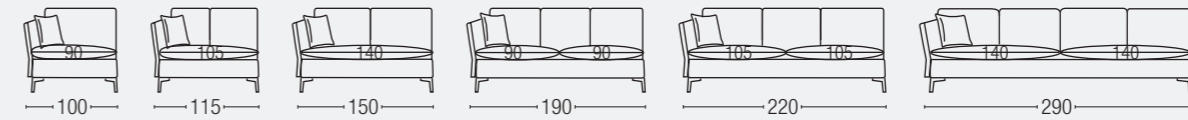

CHAISE LONGUE*

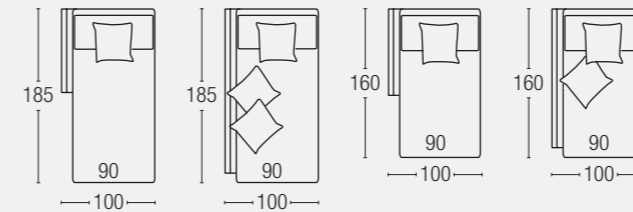

ANGOLO / CORNER

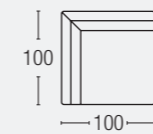

POUF

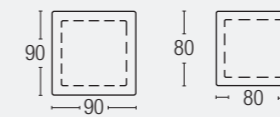

GUANCIALI / PILLOWS

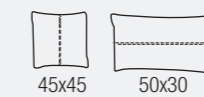

PIEDINI / FEET



Cromato / Chromed
Bronzato / Bronzed
h. 15 cm

CUCITURE A CONTRASTO/ STITCHING: CONTRAST

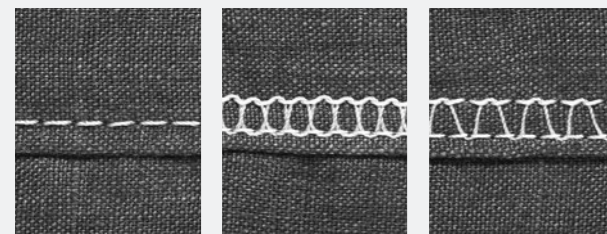

A

B

C

CUCITURE TONO SU TONO/ STITCHING: TONE ON TONE



D

E

F

MADISON

Pagina 198



Design:
Studio Archimeta

S O F A - B E D

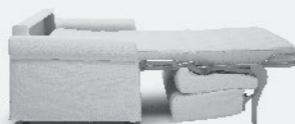

STRUTTURA

Struttura in legno e multistrato imbottita in poliuretano a quote differenziate e rivestita in resinato accoppiato dello spessore di 10 mm.

TELAIO

Telaio sotto i cuscini di seduta in multistrato per le versioni fisse.

SEDUTA

Cuscini di seduta in poliuretano densità minima 30 HR rivestiti da una falda Dacron.

SCHIENALE

Cuscini di schienale in poliuretano densità 25 HR rivestiti da una falda di Dacron.

GUANCIALE

Guanciale 100% piuma naturale lavata, depolverizzata e sterilizzata.

RETE - versione letto

Rete a maglia elettrosaldata con materasso in espanso densità 30 HR altezza 15 cm.

STRUCTURE

Laminated wood structure padded with polyurethane foam of differing densities and covered in 10 mm thick bonded resin.

FRAME

Fixed versions have a plywood frame beneath the seat cushions.

SEAT

Polyurethane padding seat cushions with minimum 30 HR density covered in a layer of Dacron.

BACK

Polyurethane padding back cushions with minimum 25 HR density covered in a layer of Dacron.

PILLOW

100% natural feather pillow; the dust-free feather filling has been cleaned and sterilised.

BAD BASE - bed version

The net is knitted electrowelded with polyurethane mattress height 15 cm in 30 HR density.

DIVANO / SOFA*

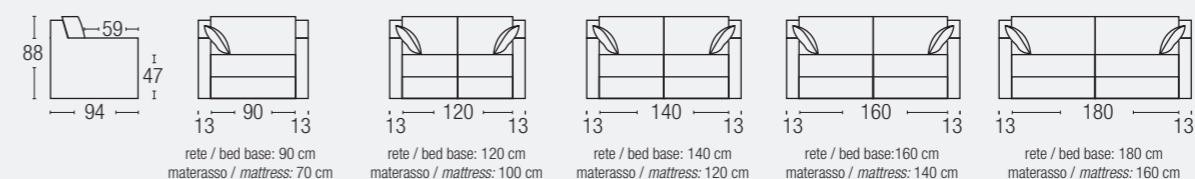

CHAISE LONGUE

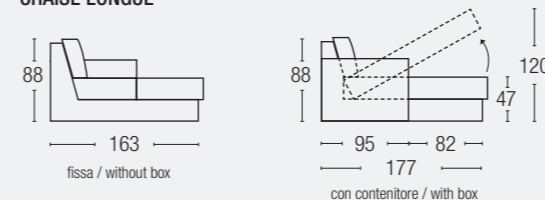

BRACCIOLI / ARMRESTS

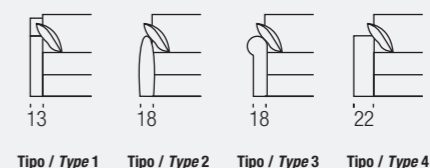

PIEDINI / FEET



A SCOMPARSA

Legno finitura wengè
Wood finish wengè
h. 5 cm
Per braccioli tipo / For Arms type: 1 / 2 / 3



LISTELLO

Wengè / Wengè
h. 5 cm
Per braccioli tipo / For Arms type: 4

BRACCIOLI / ARMS



TIPO / TYPE 1

TIPO / TYPE 2

TIPO / TYPE 3

TIPO / TYPE 4



MASTER

Pagina 114

Design:
Studio Archimeta

STRUTTURA

Struttura in legno e multistrato imbottita in poliuretano a quote differenziate e rivestita in resinato accoppiato dello spessore di 10 mm.

SEDUTA

Cuscini di seduta in poliuretano densità minima 30 HR rivestiti da una falda Dacron con inserto centrale a molle.

STRUCTURE

Laminated wood structure padded with polyurethane foam of differing densities and covered in 10 mm thick bonded resin.

SEAT

The polyurethane padding used in the seat cushions is a minimum 30 HR density covered in a layer of Dacron with central spring insert.

TELAIO

Telaio sotto i cuscini di seduta in multistrato per le versioni fisse.

GUANCIALE

Guanciaie 100% piuma naturale lavata, depolverizzata e sterilizzata.

FRAME

Fixed versions have a plywood frame beneath the seat cushions.

PILLOW

100% natural feather pillow; the dust-free feather filling has been cleaned and sterilised.

PIEDINI / FEET



LISTELLO

Cromato lucido / Polished chrome
Satinato opaco / Matt satin
Legno colore wengè / Wengè coloured wood
h. 6 cm

POGGIATESTA / HEADREST



Poggiatesta regolabile in 6 posizioni
Headrest adjustable in 6 positions

SEDUTA / SEAT



Seduta con avanzamento di 20 cm
Seat with extension of 20 cm

DIVANO / SOFA

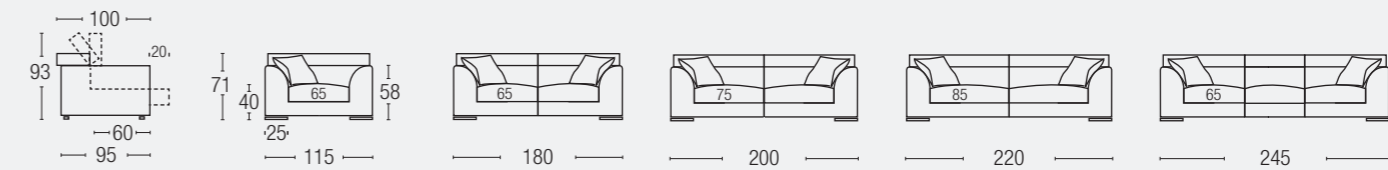

TERMINALE / ARMREST UNIT

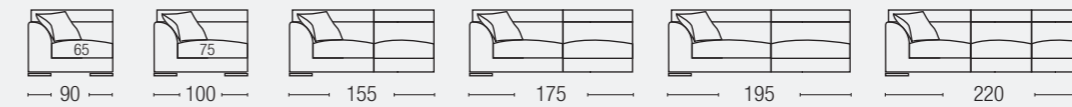

PENISOLA / PENINSULA

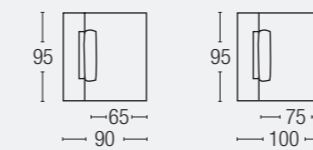

POUF

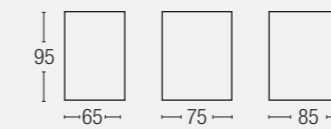

PANCA / BENCH

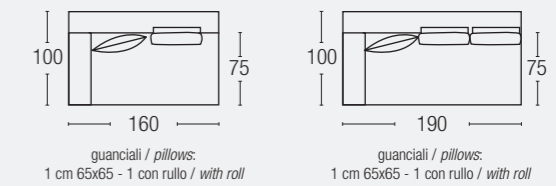

ANGOLO / CORNER

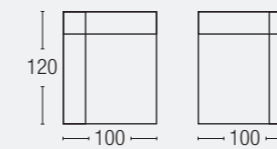

con movimento su entrambe gli schienali
Movement on both backrests

GUANCIALI / PILLOWS





NICK

Pagina 018

Design:
Arch. Danilo Bonfanti

STRUTTURA

Struttura in legno e multistrato imbottita in poliuretano a quote differenziate e rivestita in resinato accoppiato dello spessore di 10 mm.

SEDUTA

Cuscini di seduta in poliuretano densità minima 30 HR rivestiti da una falda Dacron con inserto centrale a molle.

STRUCTURE

Laminated wood structure padded with polyurethane foam of differing densities and covered in 10 mm thick bonded resin.

SEAT

The polyurethane padding used in the seat cushions is a minimum 30 HR density covered in a layer of Dacron with central spring insert.

TELAIO

Telaio sotto i cuscini di seduta in multistrato per le versioni fisse.

GUANCIALE

Guanciale 100% piuma naturale lavata, depolverizzata e sterilizzata.

FRAME

Fixed versions have a plywood frame beneath the seat cushions.

PILLOW

100% natural feather pillow; the dust-free feather filling has been cleaned and sterilised.

PIEDINI / FEET

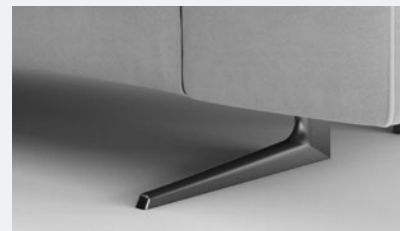

PONTE NICK

Brunito / Burnished
Cromato lucido / Polished chrome
Satinato / Satin
h. 15 cm
A richiesta / On request:
- RAL verniciato opaco / Matt RAL color

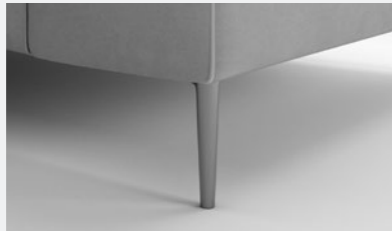

SPILLO NICK

Brunito / Burnished
Cromato lucido / Polished chrome
Satinato / Satin
h. 15 cm
A richiesta / On request:
- RAL verniciato opaco / Matt RAL color

BRACCIOLI / ARMS



Bracciolo 15 cm
Arm 15 cm

Bracciolo 25 cm
Arm 25 cm

DIVANO / SOFA*

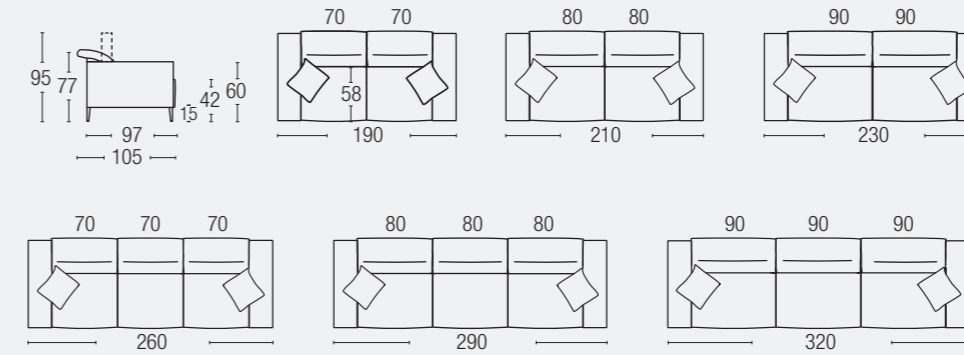

TERMINALE / ARMREST UNIT*

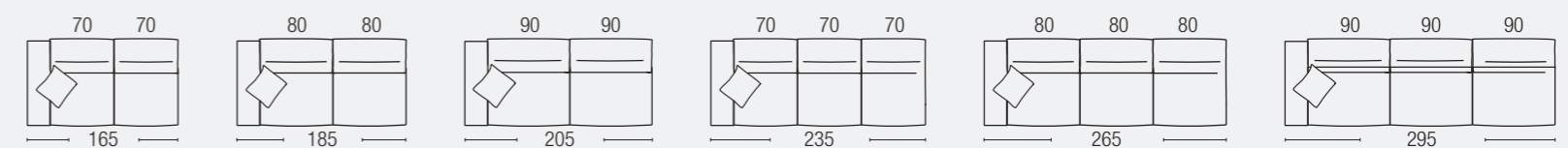

ANGOLO / CORNER

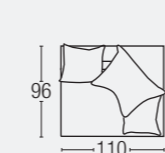

guanciali / pillows:
1 cm 65x65 - 2 cm 50x50

ANGOLARE CON POUF / CORNER WITH POUF

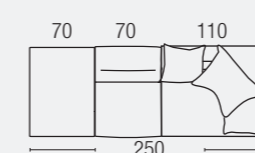

guanciali / pillows:
1 cm 65x65 - 2 cm 50x50

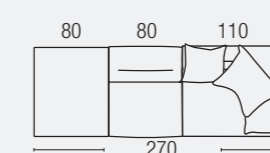

guanciali / pillows:
1 cm 65x65 - 2 cm 50x50

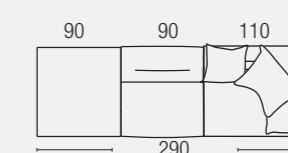

guanciali / pillows:
1 cm 65x65 - 2 cm 50x50

CHAISE LOUNGUE*

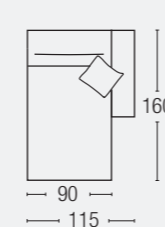

PANCA / BENCH*

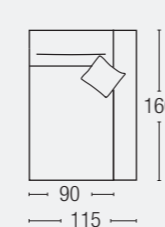

PENISOLA CON RIBALTA / PENINSULA WITH FLAP

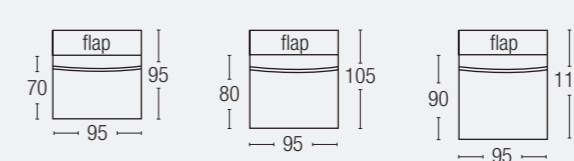

POUF

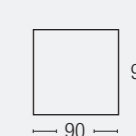



NINNA

Pagina 200

ARMCHAIR - BED



STRUTTURA

Struttura in legno e multistrato imbottita in poliuretano a quote differenziate e rivestita in resinato accoppiato dello spessore di 10 mm.

GUANCIALE

Guanciale 100% piuma naturale lavata, depolverizzata e sterilizzata.

SEDUTA

Cuscini di seduta in poliuretano densità minima 30 HR rivestiti da una falda Dacron.

RETE

Rete a maglia elettrosaldata con materasso a molle altezza 13 cm

STRUCTURE

Laminated wood structure padded with polyurethane foam of differing densities and covered in 10 mm thick bonded resin.

SEAT

Polyurethane padding seat cushions with minimum 30 HR density covered in a layer of Dacron.

PILLOW

100% natural feather pillow; the dust-free feather filling has been cleaned and sterilised.

BED BASE

The net is knitted electrowelded with spring mattress height 13 cm.

POLTRONA / ARMCHAIR

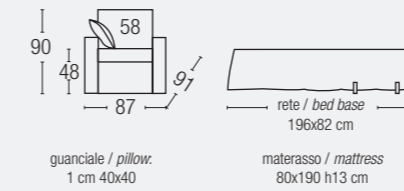

NANNA

Pagina 201

POUF - BED



SEDUTA

Cuscini di seduta in poliuretano densità minima 30 HR rivestiti da una falda Dacron.

SEAT

Polyurethane padding seat cushions with minimum 30 HR density covered in a layer of Dacron.

RETE

Rete a maglia elettrosaldata con materasso a molle altezza 13 cm

BED BASE

The net is knitted electrowelded with spring mattress height 13 cm.

POUF

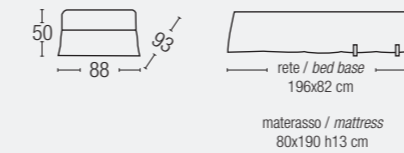



OTTO

Pagina 194

Design:
Studio Archimeta

S O F A - B E D



STRUTTURA

Struttura in legno e multistrato imbottita in poliuretano a quote differenziate e rivestita in resinato accoppiato dello spessore di 10 mm.

TELAIO

Telaio sotto i cuscini di seduta in multistrato per le versioni fisse.

SEDUTA

Cuscini di seduta in poliuretano densità minima 30 HR rivestiti da una falda Dacron.

SCHIENALE

Cuscini schienale 50% in piuma naturale depolverizzata, lavata e sterilizzata - 50% poliuretano, a camere separate orizzontalmente interamente rivestiti da una tela in cotone 100%.

GUANCIALE

Guanciale 100% piuma naturale lavata, depolverizzata e sterilizzata.

RETE - Versione letto

Rete a maglia elettrosaldata con materasso a molle altezza 15 cm

STRUCTURE

Laminated wood structure padded with polyurethane foam of differing densities and covered in 10 mm thick bonded resin.

FRAME

Fixed versions have a plywood frame beneath the seat cushions.

SEAT

Polyurethane padding seat cushions with minimum 30 HR density covered in a layer of Dacron.

BACK

Back cushions have a 50% natural feather - 50% polyurethane filling arranged in separate horizontal chambers supported with a polyurethane insert and covered entirely in a 100% cotton fabric. The dust-free feather filling has been cleaned and sterilised.

PILLOW

100% natural feather pillow; the dust-free feather filling has been cleaned and sterilised.

BAD BASE - bed version

The net is knitted electrowelded with spring mattress height 15 cm.

DIVANO / SOFA*

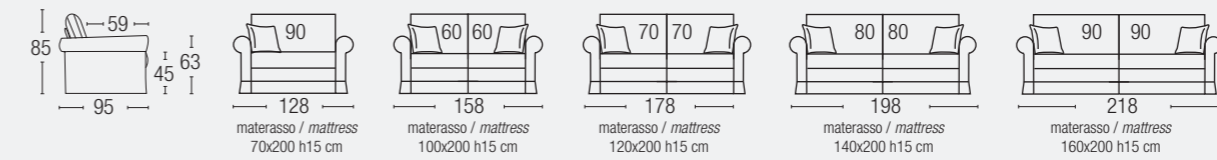

TERMINALE / ARMREST UNIT*

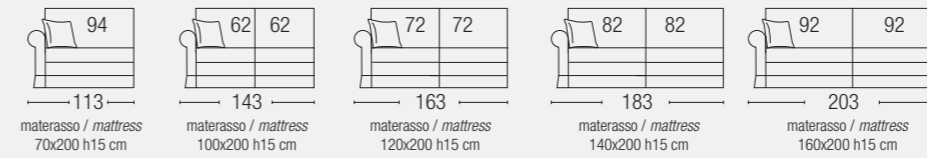

CHAISE LONGUE*

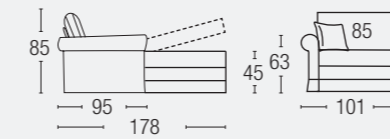

*

Profondità divano con rete aperta cm. 217 / Sofas depth with open bed cm. 217
Guanciali di serie 45x45 cm / Standard pillows 45x45 cm



PIUMA

Pagina 162

STRUTTURA

Struttura in legno e multistrato imbottita in poliuretano a quote differenziate e rivestita in resinato accoppiato dello spessore di 10 mm.

MOLLEGGIO

Molleggio della seduta in nastri elastici intrecciati ad alta densità.

SEDUTA

Cuscini di seduta in poliuretano densità minima 30 HR rivestiti da una falda Dacron con inserto centrale a molle.

SEDUTA - su richiesta

Cuscini di seduta sono 100% piuma naturale a camere separate orizzontalmente, lavata, depolverizzata e sterilizzata supportati da un inserto in poliuretano.

SCHIENALE E BRACCIOLI

Cuscini di schienale e braccioli 100% in piuma naturale depolverizzata, lavata e sterilizzata, a camere separate orizzontalmente, con inserto in poliuretano interamente rivestiti da una tela in cotone 100%.

STRUCTURE

Laminated wood structure padded with polyurethane foam of differing densities and covered in 10 mm thick bonded resin.

SUSPENSION

The seat suspension system uses high density intertwined elastic ribbons.

SEAT

The polyurethane padding used in the seat cushions is a minimum 30 HR density covered in a layer of Dacron with central spring insert.

SEAT - on request

Seat cushions have a 100% natural feather filling arranged in separate horizontal chambers supported with a polyurethane insert; the dust-free feather filling has been cleaned and sterilised.

BACK AND ARMS

Back and Arms cushions have a 100% natural feather filling arranged in separate horizontal chambers supported with a polyurethane insert and covered entirely in a 100% cotton fabric. The dust-free feather filling has been cleaned and sterilised.

DIVANO / SOFA

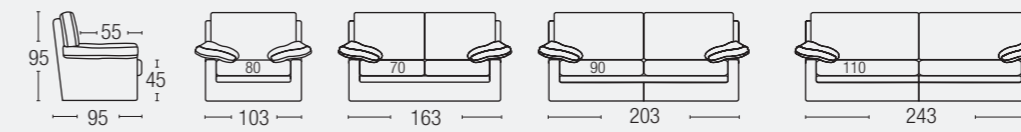

DIVANO CON LETTO / SOFA BED

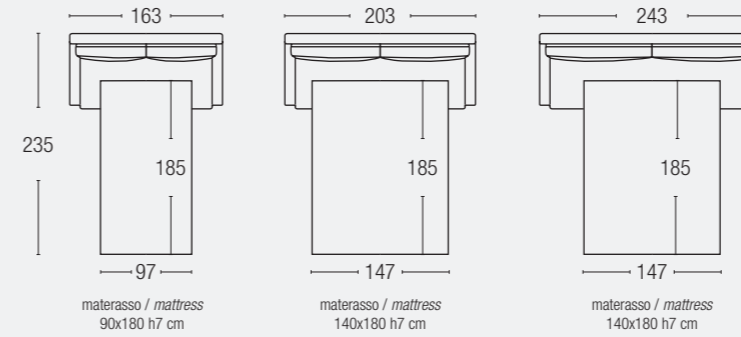

ELEMENTO CENTRALE / CENTRAL UNIT



TERMINALE / ARMREST UNIT

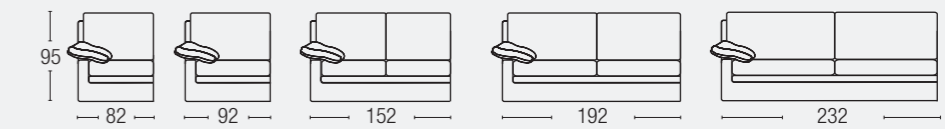

ANGOLO / CORNER

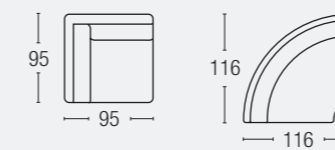

POUF

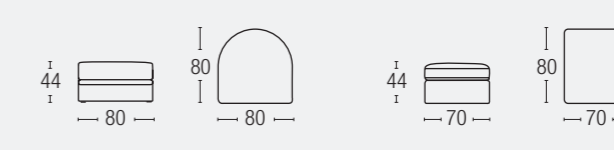



PLANO

Pagina 144

Design:
Arch. Danilo Bonfanti

STRUTTURA

Struttura in legno e multistrato imbottita in poliuretano a quote differenziate e rivestita in resinato accoppiato dello spessore di 10 mm.

MOLLEGGIO

Molleggio della seduta in nastri elastici intrecciati ad alta densità.

SEDUTA

Cuscini di seduta in poliuretano densità minima 30 HR rivestiti da una falda Dacron.

SCHIENALE

Cuscini schienale 50% in piuma naturale depolverizzata, lavata e sterilizzata - 50% poliuretano, a camere separate orizzontalmente interamente rivestiti da una tela in cotone 100%.

GUANCIALE

Guanciale 50% piuma naturale depolverizzata, lavata e sterilizzata - 50% poliuretano

STRUCTURE

Laminated wood structure padded with polyurethane foam of differing densities and covered in 10 mm thick bonded resin.

SUSPENSION

The seat suspension system uses high density intertwined elastic ribbons.

SEAT

Polyurethane padding seat cushions with minimum 30 HR density covered in a layer of Dacron.

BACK

Back cushions have a 50% natural feather - 50% polyurethane filling arranged in separate horizontal chambers supported with a polyurethane insert and covered entirely in a 100% cotton fabric. The dust-free feather filling has been cleaned and sterilised.

PILLOW

Pillow 50% natural feather - 50% polyurethane; the dust-free feather filling has been cleaned and sterilised.

DIVANO / SOFA*

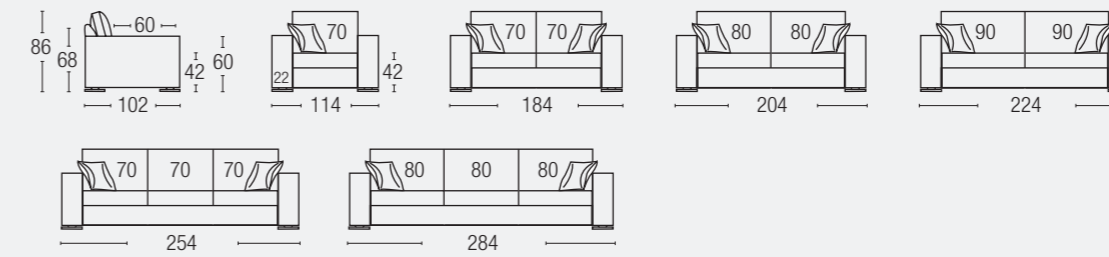

TERMINALE / ARMREST UNIT*

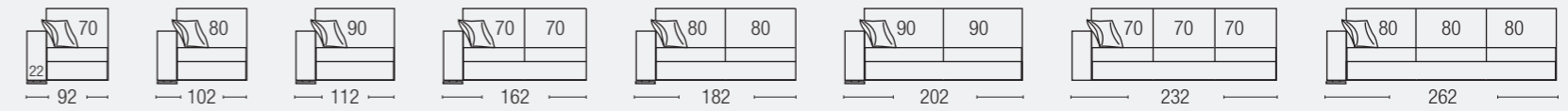

POUF

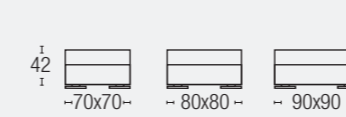

CHAISE LONGUE*

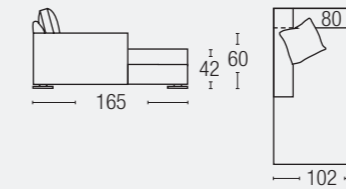

PENNISOLA / PENINSULA*

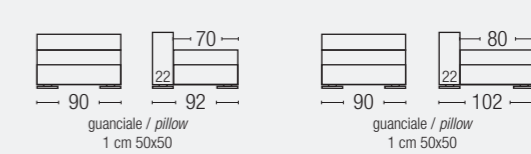

ANGOLO / CORNER

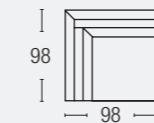

GUANCIALE / PILLOW

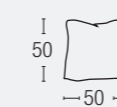

PIEDINI / FEET



BISCOTTO

In legno, frontale rivestito in metallo cromato lucido
Wood, front covered with polished chrome metal
h. 7,5 cm
A richiesta / On request h. 9,5 cm

CUCITURE A CONTRASTO/ STITCHING: CONTRAST

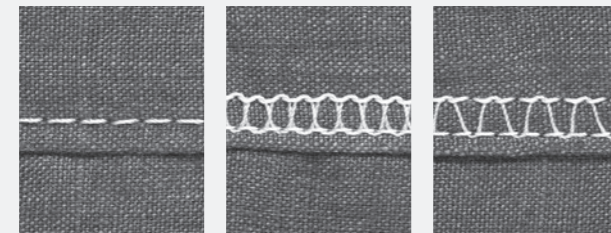

CUCITURE TONO SU TONO/ STITCHING: TONE ON TONE

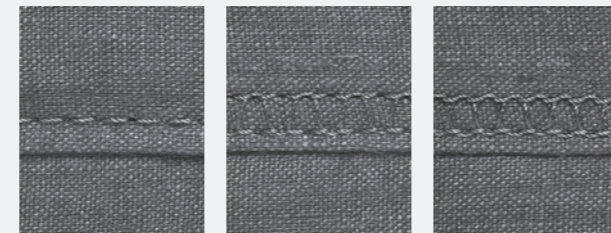

PLANO PLUS



DIVANO PLANO
PLANO SOFA

BASE POUF
POUF BASE
DX/SX

CUSCINO POUF
PILLOW POUF
DX/SX



Guarda il video
watch the video

PLANO PLUS

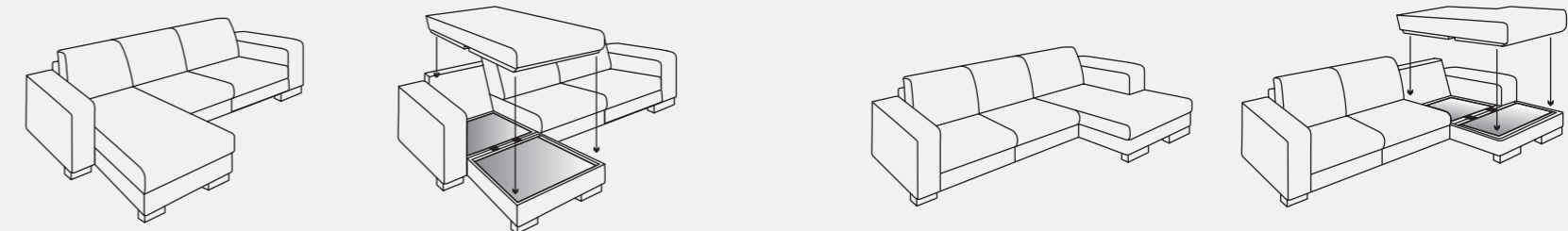

COMPOSIZIONE REVERSIBILE / REVERSIBLE COMPOSITION

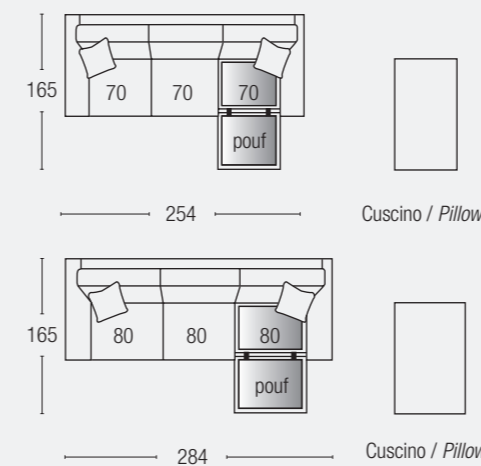

COMPOSIZIONE DX-SX / RIGHT-LEFT COMPOSITION

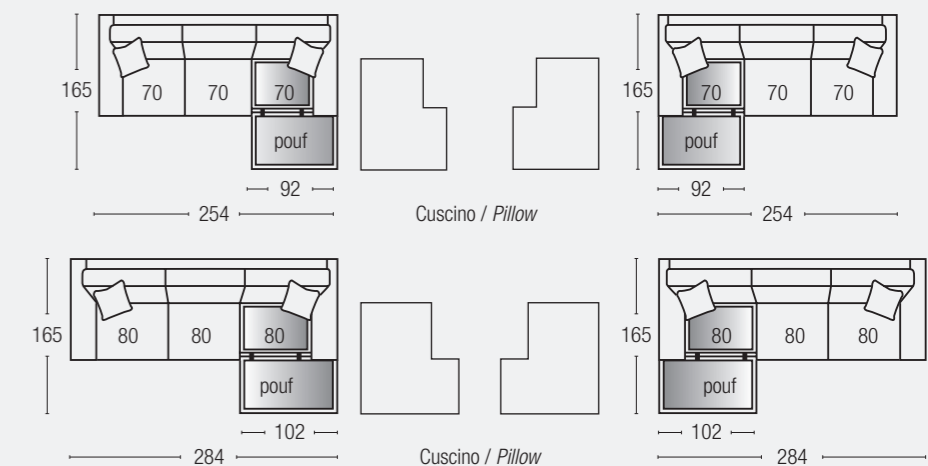



PLAY

Design:
Arch. Danilo Bonfanti

Pagina 104

STRUTTURA

Struttura in legno e multistrato imbottita in poliuretano a quote differenziate e rivestita in resinato accoppiato dello spessore di 10 mm.

STRUCTURE

Laminated wood structure padded with polyurethane foam of differing densities and covered in 10 mm thick bonded resin.

MOLLEGGIO

Molleggio della seduta in nastri elastici intrecciati ad alta densità.

SUSPENSION

The seat suspension system uses high density intertwined elastic ribbons.

SEDUTA

Cuscini di seduta in poliuretano densità minima 30 HR rivestiti da una falda Dacron.

SEAT

Polyurethane padding seat cushions with minimum 30 HR density covered in a layer of Dacron.

PIEDINI / FEET

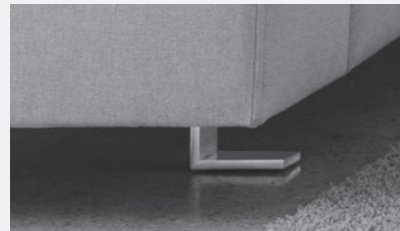

ELLE

Cromato lucido / Polished chrome
h. 10 cm

BRACCIOLI / ARMS



PLAY
Bracciolo 26 cm
Arm 26 cm

PLAY LIGHT
Bracciolo 20 cm
Arm 20 cm

PLAY ARMCHAIR
Bracciolo bombato 16 cm
Rounded arm 16 cm

DIVANO / SOFA

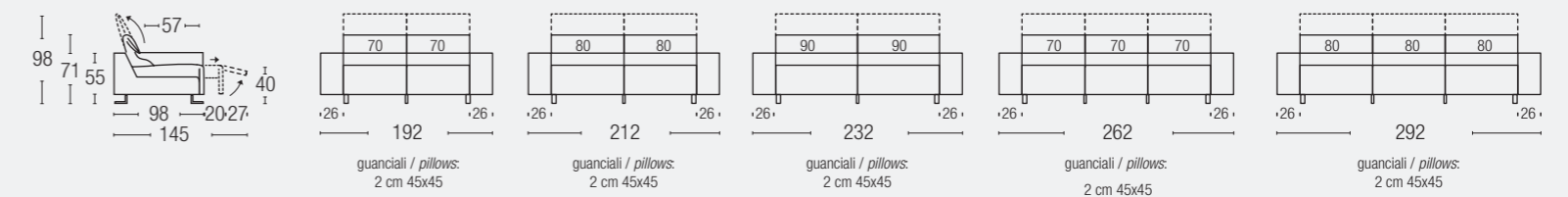

POLTRONA / ARMCHAIR

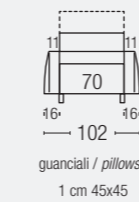

TERMINALE / ARMREST UNIT

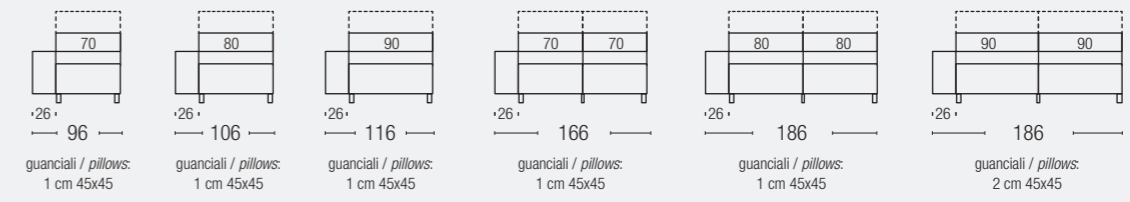

ANGOLO / CORNER

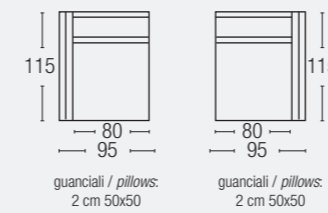

POUF

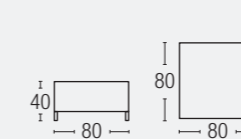



RALPH

Pagina 166

Design:
Arch. Danilo Bonfanti

STRUTTURA

Struttura in legno e multistrato imbottita in poliuretano a quote differenziate e rivestita in resinato accoppiato dello spessore di 10 mm.

MOLLEGGIO

Molleggio della seduta in nastri elastici intrecciati ad alta densità.

SEDUTA

Cuscini di seduta 100% in piuma naturale depolverizzata, lavata e sterilizzata a camere separate orizzontalmente e supportati da un inserto in poliuretano.

SCHIENALE

Cuscini schienale 100% in piuma naturale depolverizzata, lavata e sterilizzata, a camere separate orizzontalmente, con inserto in poliuretano interamente rivestiti da una tela in cotone 100%.

GUANCIALE

Guanciaie 100% piuma naturale lavata, depolverizzata e sterilizzata.

STRUCTURE

Laminated wood structure padded with polyurethane foam of differing densities and covered in 10 mm thick bonded resin.

SUSPENSION

The seat suspension system uses high density intertwined elastic ribbons.

SEAT

Seat cushions have a 100% natural feather filling arranged in separate horizontal chambers supported with a polyurethane insert; the dust-free feather filling has been cleaned and sterilised.

BACK

Back cushions have a 100% natural feather filling arranged in separate horizontal chambers supported with a polyurethane insert and covered entirely in a 100% cotton fabric. The dust-free feather filling has been cleaned and sterilised.

PILLOW

100% natural feather pillow; the dust-free feather filling has been cleaned and sterilised.

DIVANO / SOFA*

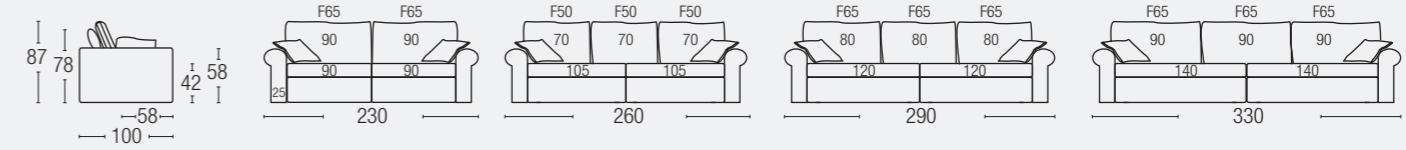

PENISOLA JOLLY / PENINSULA JOLLY

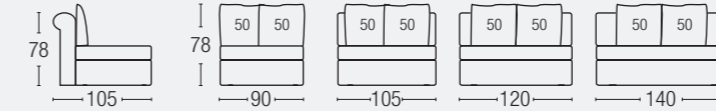

TERMINALE / ARMREST UNIT*

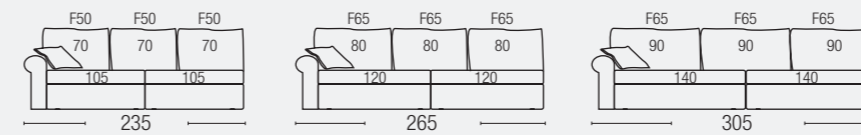
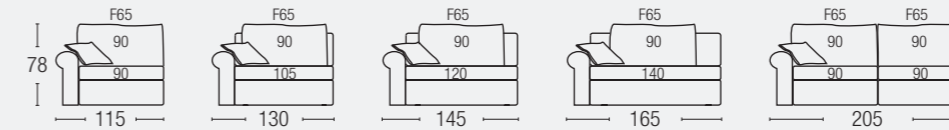

CHAISE LONGUE

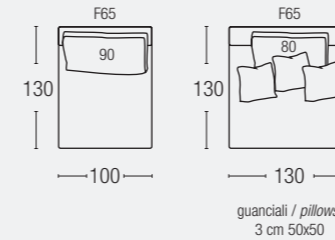



SETTE

Pagina 192

Design:
Studio Archimeta

S O F A - B E D



STRUTTURA

Struttura in legno e multistrato imbottita in poliuretano a quote differenziate e rivestita in resinato accoppiato dello spessore di 10 mm.

TELAIO

Telaio sotto i cuscini di seduta in multistrato per le versioni fisse.

SEDUTA

Cuscini di seduta in poliuretano densità minima 30 HR rivestiti da una falda Dacron.

SCHIENALE

Cuscini schienale 50% in piuma naturale depolverizzata, lavata e sterilizzata - 50% poliuretano, a camere separate orizzontalmente interamente rivestiti da una tela in cotone 100%.

GUANCIALE

Guanciaie 100% piuma naturale lavata, depolverizzata e sterilizzata.

RETE - Versione letto

Rete a maglia elettrosaldata con materasso a molle altezza 15 cm

STRUCTURE

Laminated wood structure padded with polyurethane foam of differing densities and covered in 10 mm thick bonded resin.

FRAME

Fixed versions have a plywood frame beneath the seat cushions.

SEAT

Polyurethane padding seat cushions with minimum 30 HR density covered in a layer of Dacron.

BACK

Back cushions have a 50% natural feather - 50% polyurethane filling arranged in separate horizontal chambers supported with a polyurethane insert and covered entirely in a 100% cotton fabric. The dust-free feather filling has been cleaned and sterilised.

PILLOW

100% natural feather pillow; the dust-free feather filling has been cleaned and sterilised.

BED BASE - bed version

The net is knitted electrowelded with spring mattress height 15 cm.

DIVANO / SOFA*

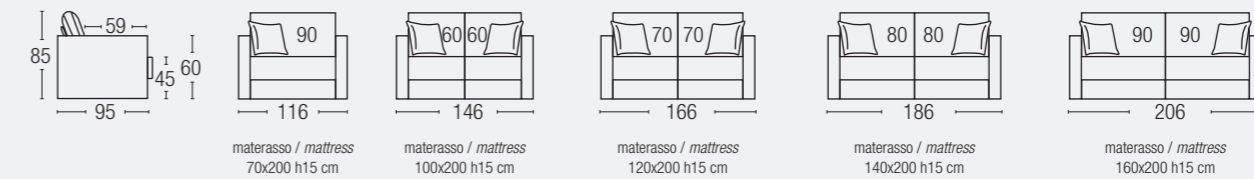

TERMINALE / ARMREST UNIT*

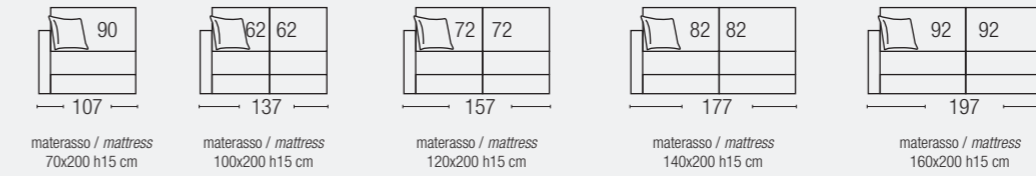

CHAISE LONGUE*

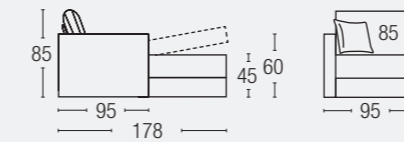



SILVER

Pagina 066

Design:
Arch. Danilo Bonfanti

STRUTTURA

Struttura in legno e multistrato imbottita in poliuretano a quote differenziate e rivestita in resinato accoppiato dello spessore di 10 mm.

MOLLEGGIO

Molleggio della seduta in nastri elastici intrecciati ad alta densità.

SEDUTA

Cuscini seduta 40% poliuretano - 40% cin fill ball (fibra poliestere siliconata cava a pallino) - 20% memory foam, a camere separate orizzontalmente interamente rivestiti da una tela in cotone 100% supportati da una base in poliuretano.

SCHIENALE

Cuscini schienale 40% poliuretano - 40% cin fill ball (fibra poliestere siliconata cava a pallino) - 20% memory foam, a camere separate orizzontalmente interamente rivestiti da una tela in cotone 100%.

GUANCIALE

Guanciale 100% piuma naturale lavata, depolverizzata e sterilizzata.

STRUCTURE

Laminated wood structure padded with polyurethane foam of differing densities and covered in 10 mm thick bonded resin.

SUSPENSION

The seat suspension system uses high density intertwined elastic ribbons.

SEAT

Cushions seat have a 40% polyurethane - 40% cin fill ball (siliconised polyester ball fibre) - 20% memory foam filling arranged in separate horizontal chambers covered entirely in a 100% cotton fabric with a polyurethane base.

BACK

Back cushions have a 40% polyurethane - 40% cin fill ball (siliconised polyester ball fibre) - 20% memory foam filling arranged in separate horizontal chambers covered entirely in a 100% cotton fabric. The dust-free feather filling has been cleaned and sterilised.

PILLOW

100% natural feather pillow; the dust-free feather filling has been cleaned and sterilised.

PIEDINI / FEET

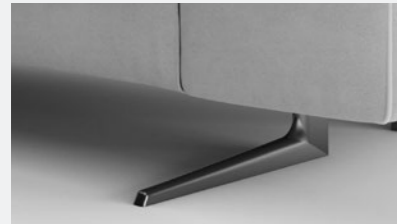

PONTE NICK

Brunito / Burnished
Cromato lucido / Polished chrome
Satinato / Satin
h. 15 cm
A richiesta / On request:
- RAL verniciato opaco / Matt RAL color



SPILLO NICK

Brunito / Burnished
Cromato lucido / Polished chrome
Satinato / Satin
h. 15 cm
A richiesta / On request:
- RAL verniciato opaco / Matt RAL color

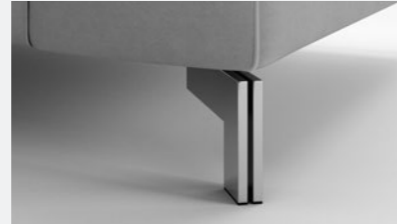

DOPPIA LAMINA

Cromato lucido / Polished chrome
h. 15 cm

BRACCIOLI / ARMS



Bracciolo 15 cm
Arm 15 cm



Bracciolo 25 cm
Arm 25 cm

ACCESSORI / ACCESSORIES



PIANO VASSOIO IN MDF / PLAN-TRAY IN MDF

Disponibile nei colori / Available in
RAL 7001/7030/9003

DIVANO / SOFA*

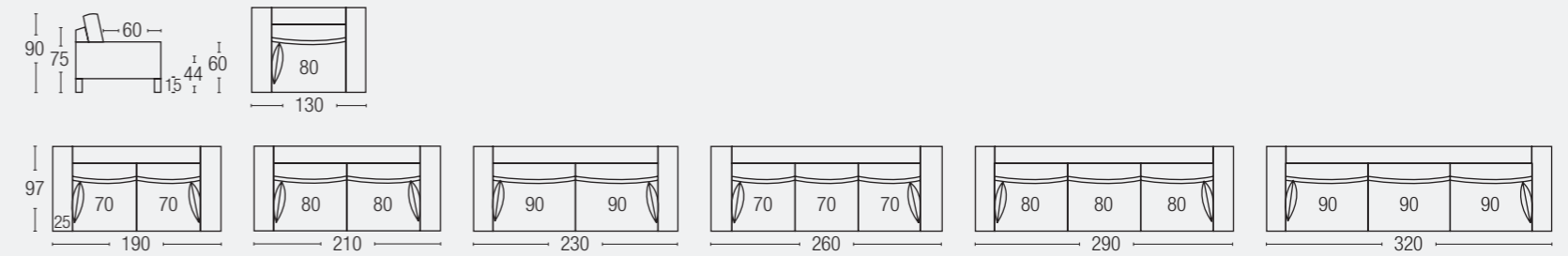

TERMINALE / ARMREST UNIT*

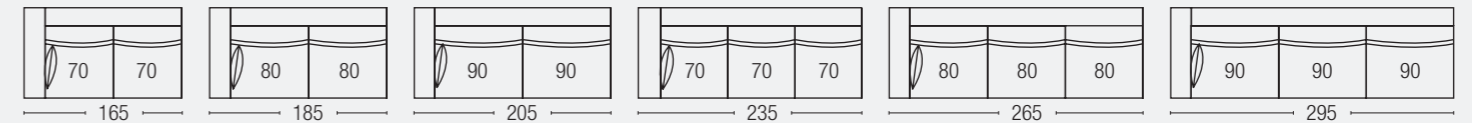

PENISOLA / PENINSULA

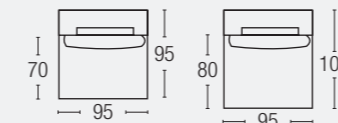

CHAISE LOUNGUE*

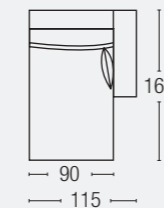

PANCA / BENCH*

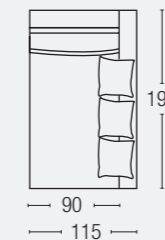

ANGOLO / CORNER

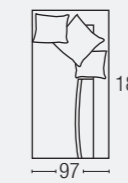

guanciali / pillows:
1 cm 65x65 - 2 cm 50x50

POUF

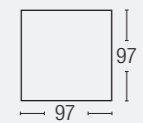

ELEMENTI CON CUSCINO-COFFEE TABLE
ELEMENTS WITH CUSHION-COFFEE TABLE

TERMINALE CON POUF / ARMREST UNIT WITH POUF*

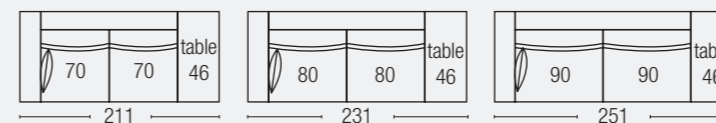

PENISOLA / PENINSULA

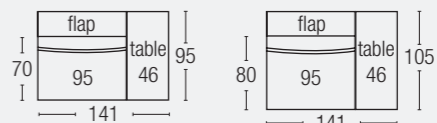

ANGOLARE CON POUF / CORNER WITH POUF

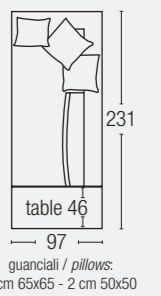

guanciali / pillows:
1 cm 65x65 - 2 cm 50x50

ESEMPI DI CONFIGURAZIONI CONFIGURATIONS EXAMPLES

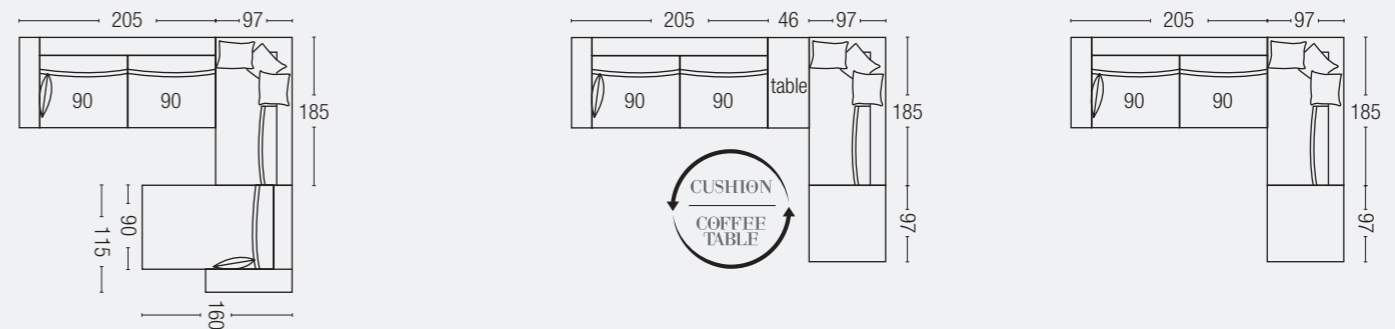



SURF

Pagina 190

Design:
Studio Archimeta

S O F A - B E D



DIVANO / SOFA

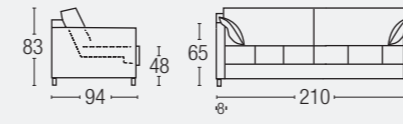

STRUTTURA

Struttura in legno e multistrato imbottita in poliuretano a quote differenziate e rivestita in resinato accoppiato dello spessore di 10 mm.

MATERASSO

MATERASSO SUPERIORE: a molle 80x190x15cm (serve anche come cuscino di seduta)
MATERASSO INFERIORE: a molle 75x188x15cm

STRUCTURE

Laminated wood structure padded with polyurethane foam of differing densities and covered in 10 mm thick bonded resin.

MATTRESS

UPPER MATTRESS: 80x190x15cm with springs (also seat cushion)
LOWER MATTRESS: 75x188x15cm with springs

SCHIENALE

Cuscini schienale 100% in piuma naturale depolverizzata, lavata e sterilizzata, a camere separate orizzontalmente, con inserto in poliuretano interamente rivestiti da una tela in cotone 100%.

RETE

Rete a maglia elettrosaldata

BACK

Back cushions have a 100% natural feather filling arranged in separate horizontal chambers supported with a polyurethane insert and covered entirely in a 100% cotton fabric. The dust-free feather filling has been cleaned and sterilised.

BED BASE

Bed base with electrowelded mesh

GUANCIALE

Guanciale 100% piuma naturale lavata, depolverizzata e sterilizzata.

PILLOW

100% natural feather pillow; the dust-free feather filling has been cleaned and sterilised.

PIEDINI / FEET



CILINDRO

Cromato lucido / Polished chrome
h. 10 cm



ZENO

Pagina 088

Design:
Arch. Danilo Bonfanti

STRUTTURA

Struttura in legno e multistrato imbottita in poliuretano a quote differenziate e rivestita in resinato accoppiato dello spessore di 10 mm.

MOLLEGGIO

Molleggio della seduta in nastri elastici intrecciati ad alta densità.

SEDUTA

Cuscini di seduta in poliuretano densità minima 30 HR rivestiti da una falda Dacron.

SCHIENALE

Cuscini schienale 50% in piuma naturale depolverizzata, lavata e sterilizzata - 50% poliuretano, a camere separate orizzontalmente interamente rivestiti da una tela in cotone 100%.

STRUCTURE

Laminated wood structure padded with polyurethane foam of differing densities and covered in 10 mm thick bonded resin.

SUSPENSION

The seat suspension system uses high density intertwined elastic ribbons.

SEAT

Polyurethane padding seat cushions with minimum 30 HR density covered in a layer of Dacron.

BACK

Back cushions have a 50% natural feather - 50% polyurethane filling arranged in separate horizontal chambers supported with a polyurethane insert and covered entirely in a 100% cotton fabric. The dust-free feather filling has been cleaned and sterilised.

PIEDINI / FEET



LAMINA

Satinato / Satin
h. 7,5 cm
A richiesta / On request h.9,5 cm



QUADRATO

A sezione quadrata / Square section
h.7,5 cm
A richiesta / On request h.9,5 cm

ZENO PLUS



DIVANO ZENO
ZENO SOFA

+



=



BASE POUF
POUF BASE
DX / SX

+



=



CUSCINO POUF
PILLOW POUF
DX / SX



Guarda il video
watch the video

DIVANO / SOFA

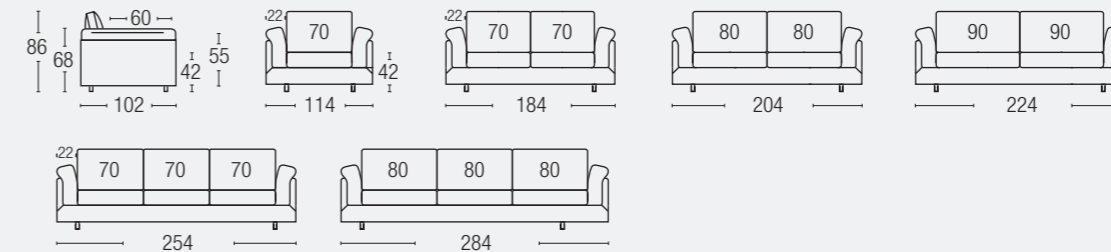

TERMINALE / ARMREST UNIT

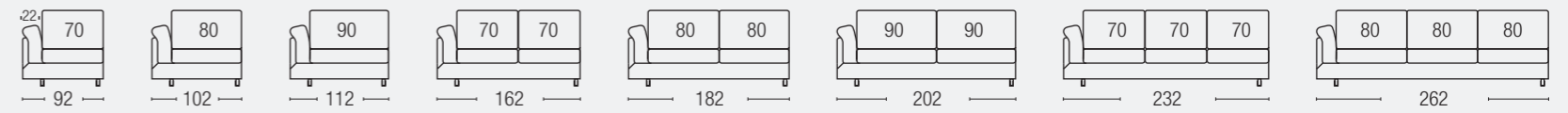

POUF

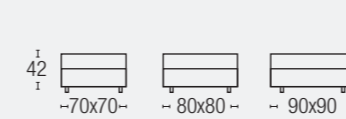

CHAISE LONGUE

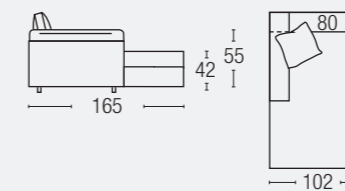

ANGOLO / CORNER

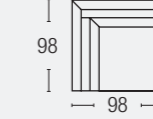

PENISOLA REVERSIBILE / REVERSIBLE PENINSULA



ZENO PLUS

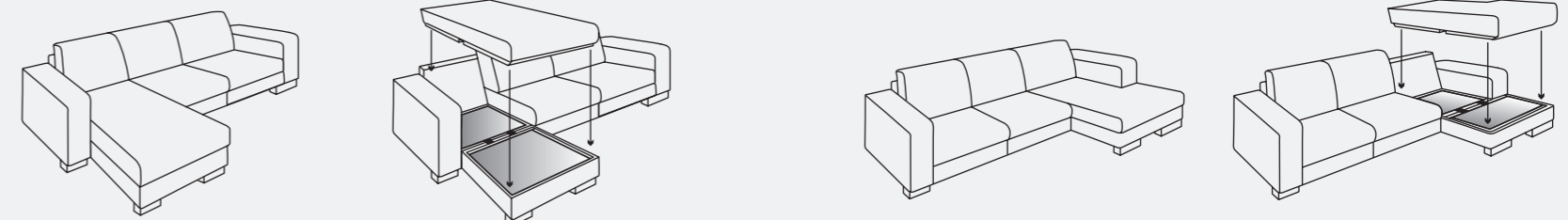

COMPOSIZIONE REVERSIBILE / REVERSIBLE COMPOSITION

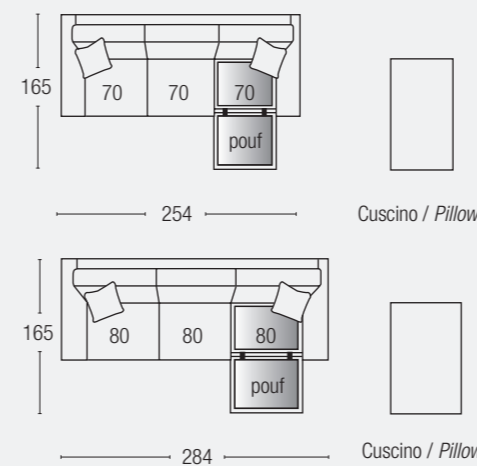

COMPOSIZIONE DX-SX / RIGHT-LEFT COMPOSITION

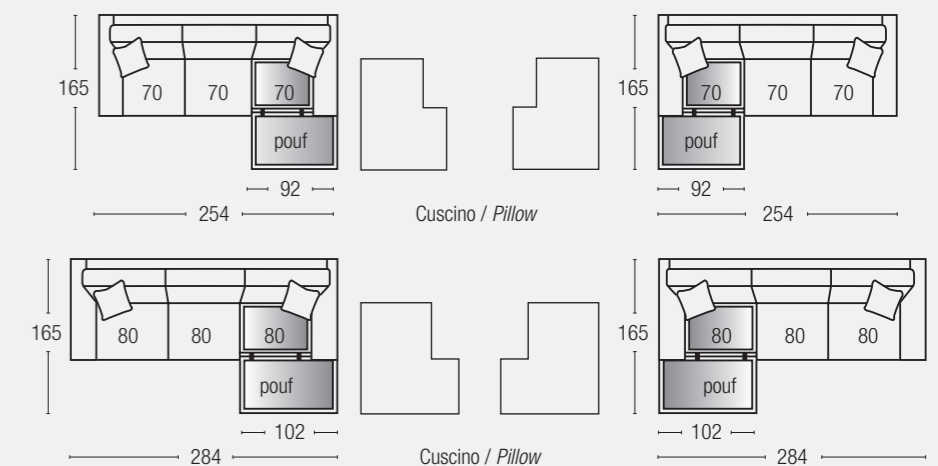



ADELAIDE

Pagina 142

POLTRONA / ARMCHAIR

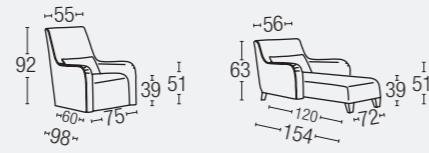

STRUTTURA

Struttura in legno e multistrato imbottita in poliuretano a quote differenziate e rivestita in resinato accoppiato dello spessore di 10 mm.

GUANCIALE

Guanciali 100% piuma naturale, lavata, depolverizzata e sterilizzata.

TELAIO

Telaio sotto i cuscini di seduta in multistrato per le versioni fisse.

PIEDINO

Fisso o girevole.

SEDUTA

Cuscini di seduta in poliuretano densità minima 30 HR rivestiti da una falda Dacron.

STRUCTURE

Laminated wood structure padded with polyurethane foam of differing densities and covered in 10 mm thick bonded resin.

PILLOW

100% natural feather pillow; the dust-free feather filling has been cleaned and sterilised.

FRAME

Fixed versions have a plywood frame beneath the seat cushions.

FEET

Fixed or swivel.

SEAT

Polyurethane padding seat cushions with minimum 30 HR density covered in a layer of Dacron.

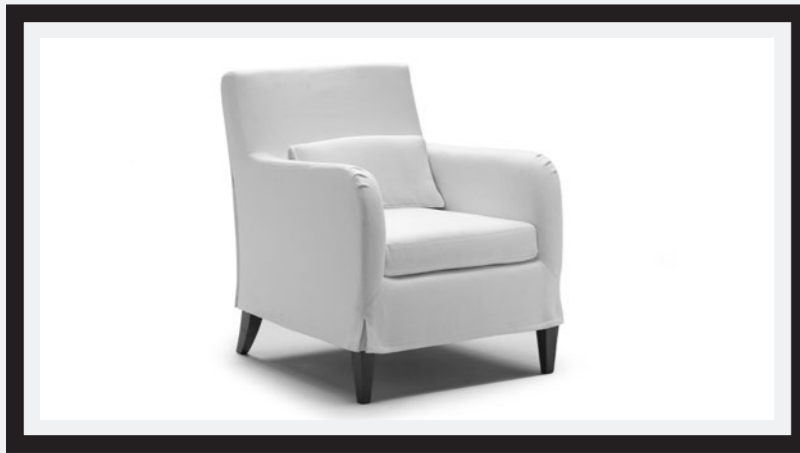

CLO RinNE

Pagina 160

POLTRONA / ARMCHAIR

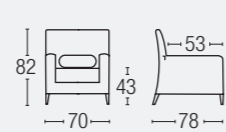

STRUTTURA

Struttura in legno e multistrato imbottita in poliuretano a quote differenziate e rivestita in resinato accoppiato dello spessore di 10 mm.

SEDUTA

Cuscini di seduta in poliuretano densità minima 30 HR rivestiti da una falda Dacron.

PIEDINO

Piedi di serie colore faggio naturale

MOLLEGGIO

Molleggio della seduta in nastri elastici intrecciati ad alta densità.

STRUCTURE

Laminated wood structure padded with polyurethane foam of differing densities and covered in 10 mm thick bonded resin.

SEAT

Polyurethane padding seat cushions with minimum 30 HR density covered in a layer of Dacron.

SUSPENSION

The seat suspension system uses high density intertwined elastic ribbons.

FEET

Standard feet natural beech colour



FROG

Pagina 054

Design:

Arch. Danilo Bonfanti

POLTRONA / ARMCHAIR

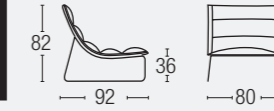

POUF

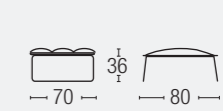

STRUTTURA

Struttura in legno e multistrato imbottita in poliuretano a quote differenziate e rivestita in resinato accoppiato dello spessore di 10 mm.

BASAMENTO

Struttura metallo cromato lucido.

MOLLEGGIO

Molleggio della seduta in nastri elastici intrecciati ad alta densità.

SEDUTA

Inseri seduta in poliuretano densità 30 HR rivestiti da una falda di Dacron.

STRUCTURE

Laminated wood structure padded with polyurethane foam of differing densities and covered in 10 mm thick bonded resin.

BASEMENT

Polished chrome metal structure.

SUSPENSION

The seat suspension system uses high density intertwined elastic ribbons.

SEAT

Polyurethane padding back cushions with minimum 25 HR density covered in a layer of Dacron.

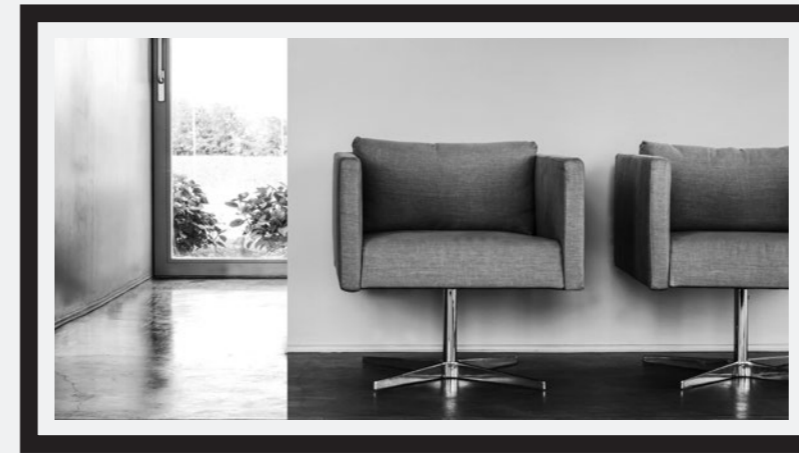

MAX

Pagina 096

Design:

Studio Archimeta

POLTRONA / ARMCHAIR

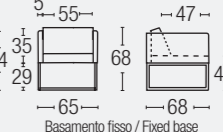

STRUTTURA

Struttura in legno e multistrato imbottita in poliuretano a quote differenziate e rivestita in resinato accoppiato dello spessore di 10 mm.

SCHIENALE

Cuscino schienale in poliuretano densità 25 HR rivestito da una falda di Dacron

BASAMENTO

GIREVOLE: metallo cromato lucido, H 28 cm
FISSO: metallo cromato lucido, H 29 cm
A richiesta colore RAL verniciato opaco

TELAIO

Telaio sotto i cuscini di seduta in multistrato per le versioni fisse.

SEDUTA

Cuscini di seduta in poliuretano densità minima 30 HR rivestiti da una falda Dacron.

STRUCTURE

Laminated wood structure padded with polyurethane foam of differing densities and covered in 10 mm thick bonded resin.

BACK

Polyurethane padding back cushions with minimum 25 HR density covered in a layer of Dacron.

FRAME

Fixed versions have a plywood frame beneath the seat cushions.

BASEMENT

SWIVEL: polished chrome metal, H 28 cm
FIXED: polished chrome metal, H 29 cm
On request, Matt RAL color

SEAT

Polyurethane padding seat cushions with minimum 30 HR density covered in a layer of Dacron.



TAG

Pagina 038

Design:
Arch. Danilo Bonfanti

POLTRONA / ARMCHAIR

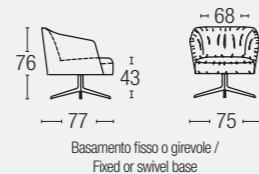

STRUTTURA

Struttura in legno e multistrato imbottita in poliuretano a quote differenziate e rivestita in resinato accoppiato dello spessore di 10 mm.

BASAMENTO

Fisso o girevole in metallo, finitura bronzata, altezza 28 cm

TELAIO

Telaio sotto i cuscini di seduta in multistrato per le versioni fisse.

SEDUTA

Cuscini di seduta in poliuretano densità minima 30 HR rivestiti da una falda Dacron.

STRUCTURE

Laminated wood structure padded with polyurethane foam of differing densities and covered in 10 mm thick bonded resin.

BASEMENT

Fixed or swivel in metal, bronzed finish, height 28 cm

FRAME

Fixed versions have a plywood frame beneath the seat cushions.

SEAT

Polyurethane padding seat cushions with minimum 30 HR density covered in a layer of Dacron.



WILLY

Pagina 161

POLTRONA / ARMCHAIR

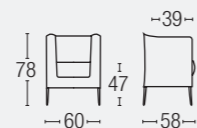

STRUTTURA

Struttura in legno e multistrato imbottita in poliuretano a quote differenziate e rivestita in resinato accoppiato dello spessore di 10 mm.

PIEDINO

Piedi di serie colore faggio naturale

STRUCTURE

Laminated wood structure padded with polyurethane foam of differing densities and covered in 10 mm thick bonded resin.

FEET

Standard feet natural beech colour

SUSPENSION

The seat suspension system uses high density intertwined elastic ribbons.

SEAT

Polyurethane padding seat cushions with minimum 30 HR density covered in a layer of Dacron.

MOLLEGGIO

Molleggio della seduta in nastri elastici intrecciati ad alta densità.

SEDUTA

Cuscini di seduta in poliuretano densità minima 30 HR rivestiti da una falda Dacron.



DISCOVERY

Pagina 170

Design:
Arch. Danilo Bonfanti

POUF

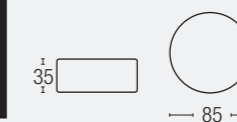

STRUTTURA

Struttura in legno e multistrato imbottita in poliuretano a quote differenziate e rivestita in resinato accoppiato dello spessore di 10 mm.

PIEDINO

Piede a scomparsa, altezza 3 cm

MOLLEGGIO

Molleggio della seduta in nastri elastici intrecciati ad alta densità.

SEDUTA

Cuscini di seduta in poliuretano densità minima 30 HR rivestiti da una falda Dacron.

STRUCTURE

Laminated wood structure padded with polyurethane foam of differing densities and covered in 10 mm thick bonded resin.

FEET

Retractable foot, height 3 cm

SUSPENSION

The seat suspension system uses high density intertwined elastic ribbons.

SEAT

Polyurethane padding seat cushions with minimum 30 HR density covered in a layer of Dacron.



POUF

Pagina 172

PUFFO

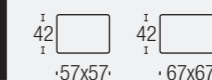

PUFFO LINE



STRUTTURA

Struttura in legno e multistrato imbottita in poliuretano a quote differenziate e rivestita in resinato accoppiato dello spessore di 10 mm.

PIEDINO

Piede a scomparsa, altezza 3 cm

MOLLEGGIO

Molleggio della seduta in nastri elastici intrecciati ad alta densità.

SEDUTA

Cuscini di seduta in poliuretano densità minima 30 HR rivestiti da una falda Dacron.

STRUCTURE

Laminated wood structure padded with polyurethane foam of differing densities and covered in 10 mm thick bonded resin.

FEET

Retractable foot, height 3 cm

SUSPENSION

The seat suspension system uses high density intertwined elastic ribbons.

SEAT

Polyurethane padding seat cushions with minimum 30 HR density covered in a layer of Dacron.

AD: Danilo Bonfanti, architetto

Photo, layout e 3D: Studio Target - Lazzate (MB)

Styling: Roberta Mari

La ditta si riserva il diritto di apportare in ogni momento modifiche tecniche ed estetiche.

The company reserves the right to change, at any time and without prior warning, the technical specifications and dimension of the articles.

La stampa tipografica non sempre permette la fedele riproduzione dei colori e delle tinte rispetto agli originali.

The printing process doesn't always permit a faithful reproduction of colours and tones as compared to the original.

biba
S A L O T T I



BIBA SALOTTI s.r.l.: Via Spezia, 187- 43126 Parma - Italy - Tel. +39 0521.293002 - Fax +39 0521.292921 - sales@bibasalotti.com - www.bibasalotti.com